

Includes
Teacher's Notes
and
Typical
Experiment Results



**Instruction Manual and
Experiment Guide for the
PASCO scientific Model
ME-9435A and ME-9429A**

012-05035E
7/94

Dynamics Cart Accessory Track Set (1.2m version)

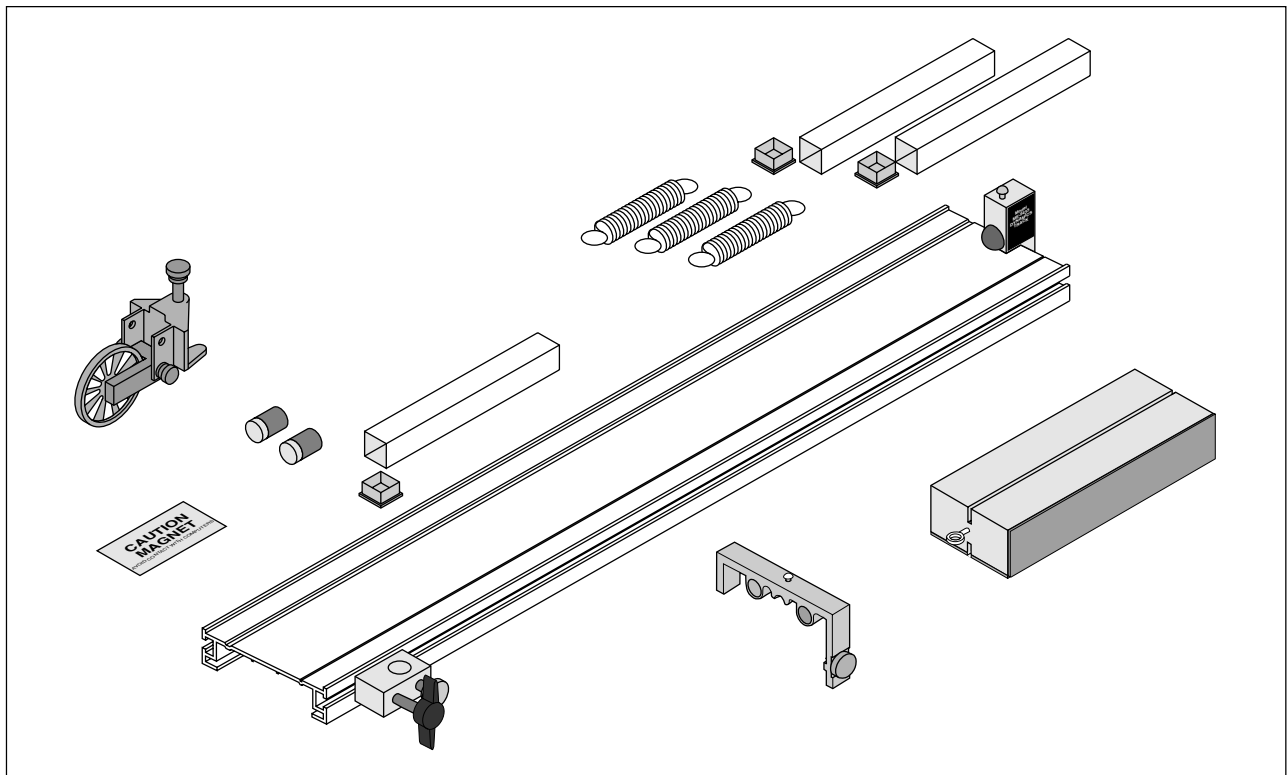

© 1992 PASCO scientific

\$10.00

PASCO[®]
scientific

10101 Foothills Blvd. • Roseville, CA 95747-7100
Phone (916) 786-3800 • FAX (916) 786-8905 • www.pasco.com

better

ways to

teach science

Table of Contents

Section	Page
Copyright, Warranty, and Equipment Return	ii
Introduction	1
Equipment	2
Assembly	3
Using the Friction Block	4
Replacement Parts	5
Experiments	
Exp 1: Conservation of Momentum in Explosions	7
Exp 2: Conservation of Momentum in Collisions	9
Exp 3: Simple Harmonic Oscillator	11
Exp 4: Oscillations on an Incline	15
Exp 5: Springs in Series and Parallel	19
Exp 6: Newton's Second Law	22
Exp 7: Newton's Second Law II	23
Exp 8: Acceleration down an Incline	25
Exp 9: Conservation of Energy	29
Additional Experiments	33
Teacher's Guide	35
Technical Support	Inside Back Cover

Copyright, Warranty and Equipment Return

Please—Feel free to duplicate this manual subject to the copyright restrictions below.

Copyright Notice

The PASCO scientific Model ME-9435A Dynamics Cart Accessory Track Set manual is copyrighted and all rights reserved. However, permission is granted to non-profit educational institutions for reproduction of any part of this manual providing the reproductions are used only for their laboratories and are not sold for profit. Reproduction under any other circumstances, without the written consent of PASCO scientific, is prohibited.

Limited Warranty

PASCO scientific warrants this product to be free from defects in materials and workmanship for a period of one year from the date of shipment to the customer. PASCO will repair or replace, at its option, any part of the product which is deemed to be defective in material or workmanship. This warranty does not cover damage to the product caused by abuse or improper use. Determination of whether a product failure is the result of a manufacturing defect or improper use by the customer shall be made solely by PASCO scientific. Responsibility for the return of equipment for warranty repair belongs to the customer. Equipment must be properly packed to prevent damage and shipped postage or freight prepaid. (Damage caused by improper packing of the equipment for return shipment will not be covered by the warranty.) Shipping costs for returning the equipment, after repair, will be paid by PASCO scientific.

Credits

This manual authored by: Ann & John Hanks

Teacher's guide written by: Eric Ayars

Equipment Return

Should the product have to be returned to PASCO scientific for any reason, notify PASCO scientific by letter, phone, or fax BEFORE returning the product. Upon notification, the return authorization and shipping instructions will be promptly issued.

► **NOTE:** NO EQUIPMENT WILL BE ACCEPTED FOR RETURN WITHOUT AN AUTHORIZATION FROM PASCO.

When returning equipment for repair, the units must be packed properly. Carriers will not accept responsibility for damage caused by improper packing. To be certain the unit will not be damaged in shipment, observe the following rules:

- ① The packing carton must be strong enough for the item shipped.
- ② Make certain there are at least two inches of packing material between any point on the apparatus and the inside walls of the carton.
- ③ Make certain that the packing material cannot shift in the box or become compressed, allowing the instrument come in contact with the packing carton.

Address: PASCO scientific
10101 Foothills Blvd.
Roseville, CA 95747-7100

Phone: (916) 786-3800
FAX: (916) 786-3292
email: techsupp@pasco.com
web: www.pasco.com

Introduction

The PASCO Model ME-9435A Dynamics Cart Accessory Track Set enables the user to perform a wide variety of experiments when used with the Dynamics Cart (ME-9430) and the Collision Cart (ME-9454). The Track ensures easy setup and accurate alignment with the lowest possible friction, and it accommodates most linear motion experiments.

Features include:

- Length is adequate for standard experiments and limited lab and table space.
- Low friction wheel slots keep the carts aligned even after a collision.
- Mounted to a standard lab rod, the track adjusts to any angle for inclined plane experiments.
- Durable construction with built-in End Stop to protect the cart.
- Adjustable End Stop allows the use of any length of track

Equipment

The ME-9435A Dynamics Cart Accessory Track Set includes the following:

- Dynamics Cart Track:
1.2m extruded aluminum track with alignment grooves in top surface, leveling foot and bumper block.

► **NOTE:** The bumper block has a round head screw on the top to allow easy attachment of springs, string, etc.

- Adjustable End Stop
- Super Pulley with Clamp.
- (3) Springs for simple harmonic motion with storage tubes.

► **NOTE:** A small piece of double sided tape is attached to the ends of each storage tube so the tubes may be permanently attached to the underside of the Dynamics Cart Track.

- Friction Block
- Magnet Bumper Kit (includes 2 magnets) with storage tube.
- Pivot Clamp [for use with the Base and Support Rod (ME-9355)].
- Label: "CAUTION! MAGNET".

Additional Equipment Required for ME-9458

- Dynamics Cart with Mass (ME-9430)

Specific experiment requirements:

- Thread
- Mass Set
- Super Pulley with Clamp
- Base and Support Rod
- Metric Ruler
- Stopwatch
- Mass balance
- Wooden or metal block
- Graph paper

Additional Equipment Recommended

- Photogate Accessory Kit with Software, (Apple) (ME-9436) or (IBM PC) (ME-9437)
- or
- Software Accessory Kit, (Apple) (ME-9438) or (IBM PC) (ME-9439).

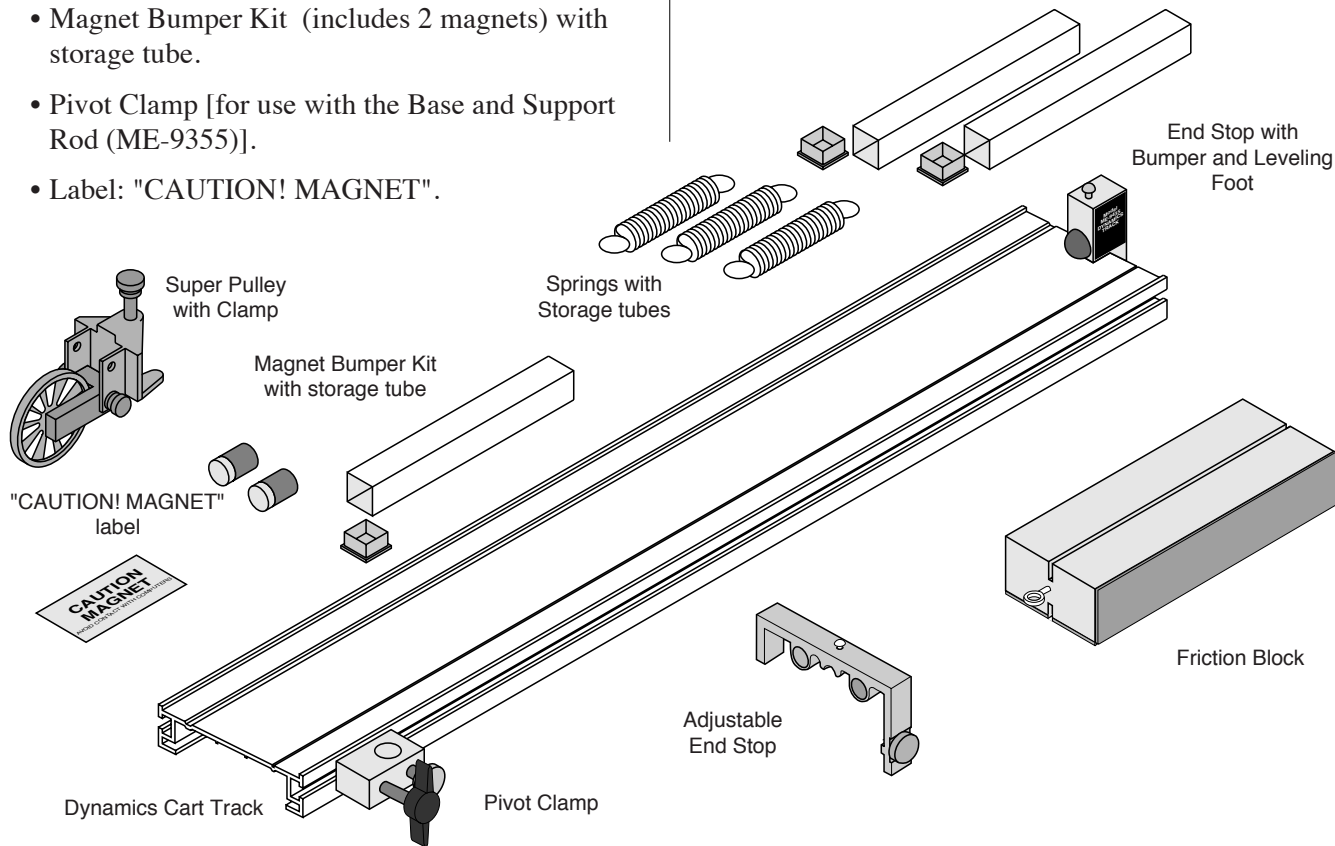

Assembly

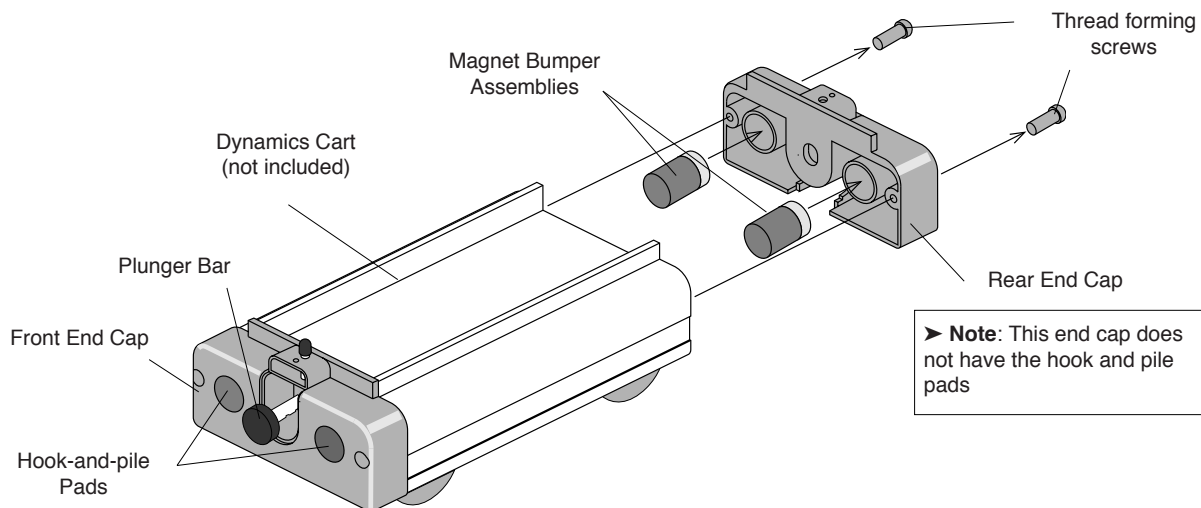

Installing the Magnet Bumpers

► **NOTE:** The ME-9454 Collision Cart comes with 2 sets of magnetic bumpers already installed. The ME-9430 Dynamics Cart comes without any magnetic bumpers.

- ① Detach the end cap at the rear of the cart by removing the two screws from the rear end cap as shown.

► **NOTE:** The screws that secure the end caps to either end of the Dynamics Cart are thread forming screws and may require substantial force to remove and reinstall. A #1 Phillips point screw driver is required.

- ② Insert the two magnet bumper assemblies, magnet end first, into the cavities on the inside of the end cap as shown.

► CAUTION!

Each magnet assembly consists of a foam pad attached to a neodymium magnet. *The neodymium magnets are extremely strong.* Though only the south end of the magnet is exposed they can still be a hazard. When opposite poles are brought close to each other they will accelerate rapidly and can pinch fingers or be easily chipped. They can also erase computer disks and distort computer monitors and television sets.

- ③ Replace the rear end cap with the two screws.

Installing the Pivot Clamp

- ① Remove Pivot Clamp Assembly from underneath the Dynamics Cart Track.
- ② Insert long thumb screw through the hole in the Pivot Clamp Block and thread $\frac{1}{2}$ to $\frac{3}{4}$ turn into the hex nut.

► **NOTE:** Observe the orientation of the Pivot Clamp Block. Also note that the flat side of the square nut must face the outside of the Dynamics Cart Track as shown.

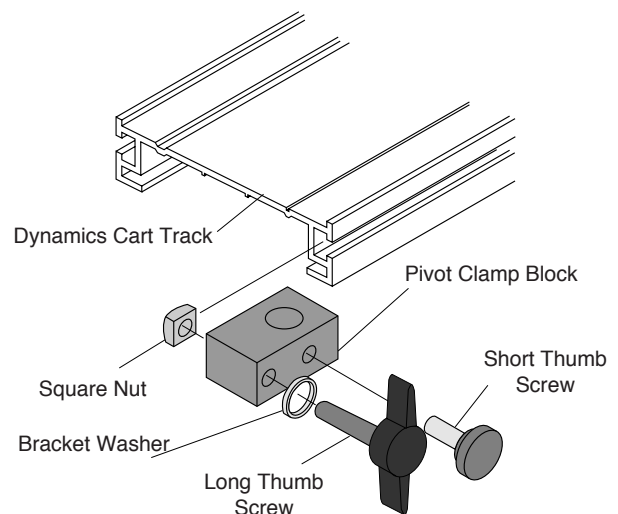

- ③ Align the square nut within the groove on the desired side of the Dynamics Cart Track. Locate and adjust Pivot Clamp to desired position and tighten thumb screw to secure.

Installing the Adjustable End Stop

The Adjustable End Stop can be used at any point on the track as a bumper. Either the plunger bar on the cart or the cart's magnetic bumper can be used to rebound off the End Stop because the End Stop contains magnets. The cart can also be stopped against the End Stop when the velcro end of the cart hits the velcro side of the End Stop. This is useful when it is desired to keep the cart from rebounding. There is also a post on top of the End Stop to allow a string or spring to be attached. Assembly is as follows:

- ① The Adjustable End Stop Assembly consists of the End Stop with two magnets installed, a black plastic thumb screw, and a square nut.
- ② If photogate brackets are to be used, it is best to install the End Stops in the groove opposite to the side being used for photogates so the End Stop can slide past the photogates without interference.
- ③ Align the square nut within the groove on the desired side of the Dynamics Cart Track as shown. Locate and adjust the End Stop to the desired position and tighten the thumb screw to secure.

- ④ When storing the End Stop when it is not on the track, remember that it has two strong magnets in it. Keep the End Stop away from computers.

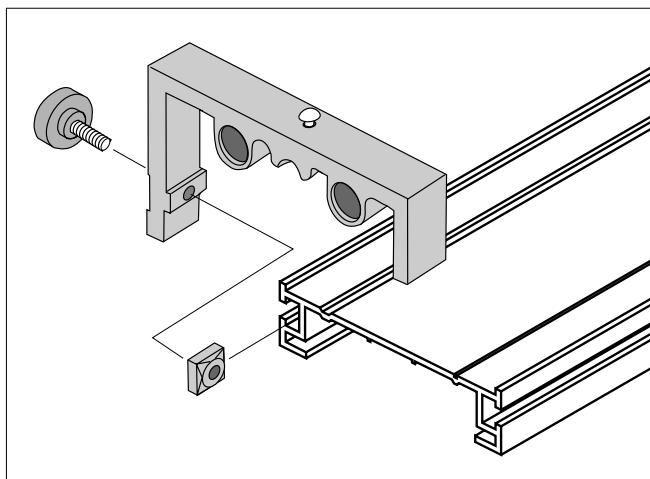

Attaching Adjustable End-Stop to Track

Using the Friction Block

The Friction Block is a wood rectangle that fits neatly on top of the Dynamics Cart (ME-9430).

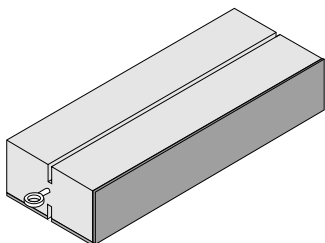

In experiments that use the Friction Block you will investigate some of the properties of sliding friction - the force that resists the sliding motion of two objects when they are already in motion.



The top and bottom surfaces of the Friction Block have a slot which allows a "picket fence" to be inserted. (See the PASCO catalog.) An eye screw is provided so that you may easily attach a string to the block.

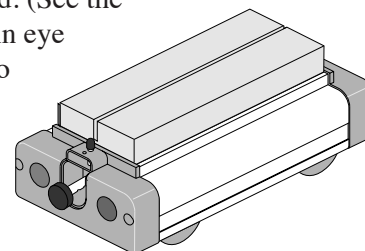

The exposed wood on the top and one side of the block produce minimal friction. Felt pads attached to the bottom surface and the other side provide more friction. Mass can be placed on the top surface of the Friction Block as shown.

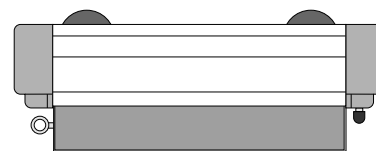

Replacement Parts (ME-9435A)

Description	Part No.
Magnet Bumper Kit Assembly (2per)	003-05027
Super Pulley with Clamp (1ea)	ME-9448A
Friction Block (1ea)	003-04708
Label, Magnet Caution (1ea)	646-04445
Spring (3ea)	632-04978
Pivot Clamp Assembly:	003-05019
Pivot clamp (1ea)	648-04654
Long thumb screw (1ea)	610-183 & 620-047
Short thumb screw (1ea)	610-181 & 620-067
Washer	615-184
Square nut (1ea)	614-054
Adjustable End Stop (1ea)	003-04989
Fixed End Stop (1ea)	003-05018

Notes:

Experiment 1: Conservation of Momentum in Explosions

EQUIPMENT NEEDED:

- Dynamic Cart with Mass (ME-9430)
- Collision Cart (ME-9454)
- Dynamics Cart Track
- Meter stick
- Mass balance

Purpose

The purpose of this experiment is to demonstrate conservation of momentum for two carts pushing away from each other.

Theory

When two carts push away from each other and no net force exists, the total momentum of both carts is conserved. Because the system is initially at rest, the final momentum of the two carts must be equal in magnitude and opposite in direction so the resulting total momentum of the system is still zero.

$$p = m_1\vec{v}_1 - m_2\vec{v}_2 = 0$$

Therefore, the ratio of the final speeds of the carts is equal to the ratio of the masses of the carts.

$$\frac{v_1}{v_2} = \frac{m_2}{m_1}$$

To simplify this experiment, the starting point for the carts at rest is chosen so that the two carts will reach the end of the track simultaneously. The speed, which is the distance divided by the time, can be determined by measuring the distance traveled since the time traveled by each cart is the same.

$$\frac{v_1}{v_2} = \frac{\frac{\Delta x_1}{\Delta t}}{\frac{\Delta x_2}{\Delta t}} = \frac{\Delta x_1}{\Delta x_2}$$

Thus the ratio of the distances is equal to the ratio of the masses:

$$\frac{\Delta x_1}{\Delta x_2} = \frac{m_2}{m_1}$$

Procedure

- ① Level the track by setting a cart on the track to see which way it rolls. Adjust the leveling feet to raise or lower the ends until a cart placed at rest on the track will not move.

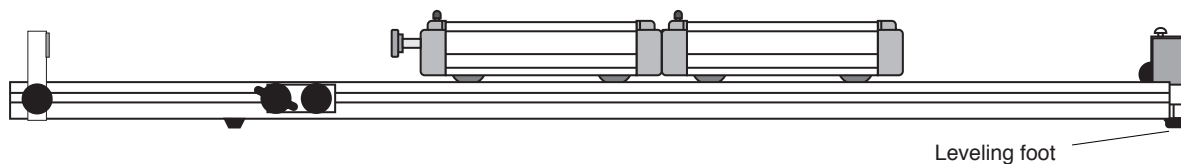

- ② For each of the following cases, place the two carts against each other with the plunger of the Dynamics Cart pushed completely in and latched in its maximum position (see Figure 1.1).
- ③ Push the plunger release button with a short stick and watch the two carts move to the ends of the track. Experiment with different starting positions until the two carts reach their respective ends of the track at the same time. Then weigh the two carts and record the masses and the starting position in Table 1.1.

CASE 1: CARTS OF EQUAL MASS (Use two carts without any additional mass bars)

CASE 2: CARTS OF UNEQUAL MASS (Put one mass bar in one cart, none in the other)

CASE 3: CARTS OF UNEQUAL MASS (Put two mass bars in one cart, none in the other)

CASE 4: CARTS OF UNEQUAL MASS (Put two mass bars in one cart, one mass bar in the other)

Table 1.1

Mass 1	Mass 2	Position	x_1	x_2	x_1/x_2	m_2/m_1

Data Analysis

- ① For each of the cases, calculate the distances traveled from the starting position to the end of the track. Record the result in Table 1.1.
- ② Calculate the ratio of the distances traveled and record in the table.
- ③ Calculate the ratio of the masses and record in the table.

Questions

- ① Does the ratio of the distances equal the ratio of the masses in each of the cases? In other words, is momentum conserved?
- ② When carts of unequal masses push away from each other, which cart has more momentum?
- ③ When the carts of unequal masses push away from each other, which cart has more kinetic energy?
- ④ Is the starting position dependent on which cart has its plunger cocked? Why?

Experiment 2: Conservation of Momentum in Collisions

EQUIPMENT NEEDED:

- Dynamics Cart with Mass (ME-9430)
- Collision Cart (ME-9454)
- (2) Bumper magnet set (installed)
- Dynamics Cart Track
- Paper

Purpose

The purpose of this experiment is to qualitatively explore conservation of momentum for elastic and inelastic collisions.

Theory

When two carts collide with each other, the total momentum $\vec{p} = m\vec{v}$ of both carts is conserved regardless of the type of collision. An elastic collision is one in which the two carts bounce off each other with no loss of kinetic energy. In this experiment, magnetic bumpers are used to minimize the energy losses due to friction during the collision. In reality, this “elastic” collision is slightly inelastic. A completely inelastic collision is one in which the two carts hit and stick to each other. In this experiment, this is accomplished with the hook-and-pile tabs on the end caps of the carts.

Procedure

- ① Level the track by setting a cart on the track to see which way it rolls. Adjust the leveling feet at the end of the track to raise or lower that end until a cart placed at rest on the track will not move.
- ② Draw two diagrams (one for before the collision and one for after the collision) for each of the following cases. In each diagram, show a velocity vector for each cart with a length that approximately represents the relative speed of the cart.

Part I: Elastic Collisions

A. Carts with Equal Mass

Orient the two carts so their magnetic bumpers are toward each other.

Case 1: Place one cart at rest in the middle of the track. Give the other cart an initial velocity toward the cart at rest.

Case 2: Start the carts with one at each end of the track. Give each cart approximately the same velocity toward each other.

Case 3: Start both carts at one end of the track. Give the first cart a slow velocity and the second cart a faster velocity so that the second cart catches the first cart.

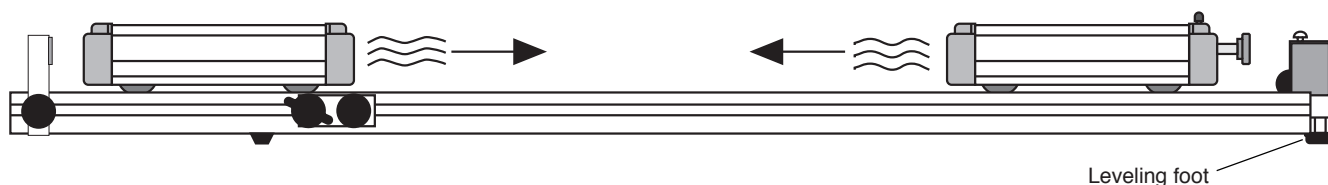

B. Carts with Unequal Mass

Put two mass bars in one of the carts so that the mass of one cart is approximately three times the mass ($3M$) of the other cart ($1M$).

Case 1: Place the $3M$ cart at rest in the middle of the track. Give the other cart an initial velocity toward the cart at rest.

Case 2: Place the $1M$ cart at rest in the middle of the track. Give the $3M$ cart an initial velocity toward the cart at rest.

Case 3: Start the carts with one at each end of the track. Give each cart approximately the same velocity toward each other.

Case 4: Start both carts at one end of the track. Give the first cart a slow velocity and the second cart a faster velocity so that the second cart catches the first cart. Do this for both cases: with the $1M$ cart first and then for the $3M$ cart first.

Part II: Completely Inelastic Collisions:

- ③ Orient the two carts so their hook-and-pile ends are toward each other. Make sure the plunger bar is pushed in completely so it won't interfere with the collision.
- ④ Repeat the same procedures listed in **Part I** for carts with equal mass **and** carts with unequal mass.

Questions

- ① When two carts having the same mass and the same speed collide and stick together, they stop. What happened to each cart's momentum? Is momentum conserved?
- ② When two carts having the same mass and the same speed collide and bounce off of each other elastically, what is the final total momentum of the carts?

Experiment 3: Simple Harmonic Oscillator

EQUIPMENT NEEDED:

- | | |
|---|---|
| <ul style="list-style-type: none"> – Dynamics Cart with Mass (ME-9430) – (2) Springs – Mass hanger and mass set (ME-9348) – String – Graph paper | <ul style="list-style-type: none"> – Dynamics Cart Track – Super Pulley with Clamp – Stopwatch – Mass balance (SE-8723) |
|---|---|

Purpose

The purpose is to measure the period of oscillation of a spring and mass system and compare it to the theoretical value.

Theory

For a mass attached to a spring, the theoretical period of oscillation is given by

$$T = 2\pi\sqrt{\frac{m}{k}}$$

where **T** is the time for one complete back-and-forth motion, **m** is the mass that is oscillating, and **k** is the spring constant.

According to Hooke's Law, the force exerted by the spring is proportional to the distance the spring is compressed or stretched, $\mathbf{F} = \mathbf{kx}$, where **k** is the proportionality constant. Thus the spring constant can be experimentally determined by applying different forces to stretch the spring different distances. Then the force is plotted versus distance and the slope of the resulting straight line is equal to **k**.

Procedure

Measurements to Find the Theoretical Period

- ① Use the balance to find the mass of the cart. Record this value at the top of Table 3.1.
- ② Level the track by setting the cart on the track to see which way it rolls. Adjust the leveling feet at the ends of the track to raise or lower the ends until the cart placed at rest on the track will not move. Put the pulley with the table clamp at one end of the track.
- ③ Set the cart on the track and attach a spring to each end of the cart by inserting the end of the spring in the hole provided in the cart. Then attach the other ends of the springs to the endstops (See Figure 3.1).
- ④ Attach a string to the end of the cart and hang a mass hanger over the pulley as shown.
- ⑤ Record the equilibrium position in Table 3.1.
- ⑥ Add mass to the mass hanger and record the new position. Repeat this for a total of 5 different masses, being careful not to over-stretch the springs. Because both springs are acting on the mass, this method will give the effective spring constant for both springs.

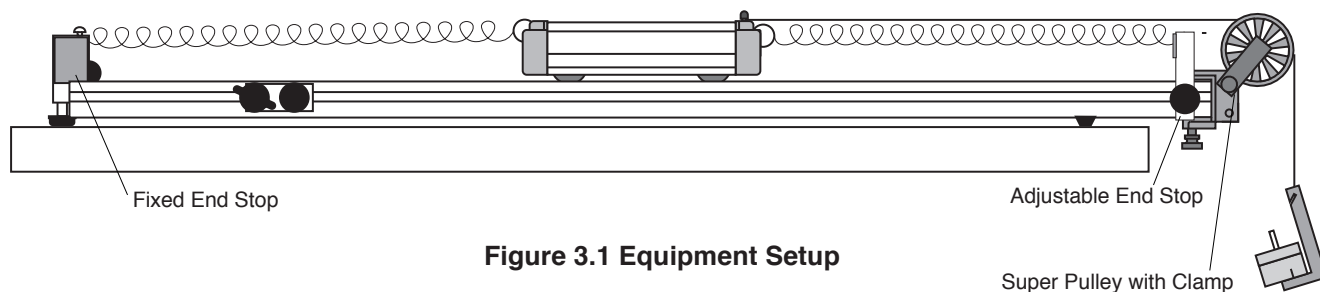

Figure 3.1 Equipment Setup

Data and Analysis

Table 3.1

Mass of cart = _____

Equilibrium position = _____

Added Mass	Position	Displacement from Equilibrium	Force (mg)

Measuring the Experimental Period

- ⑦ Displace the cart from equilibrium a specific distance and let it go. Time 5 oscillations and record the time in Table 3.2.
- ⑧ Repeat this measurement at least 5 times, using the same initial displacement (amplitude).
- ⑨ Add a 500 g mass to the cart. Measure the time for 5 oscillations 5 times and record this data in Table 3.2.

Calculations

Theoretical Period

- ① Using the data in Table 3.1, plot force versus displacement. Draw the best-fit straight line through the data points and determine the slope of the line. The slope is equal to the effective spring constant, **k**.

$k =$ _____

- ② Using the mass of the cart and the spring constant, calculate the period using the theoretical formula. Also calculate the theoretical period for the cart with the 500 g mass in it.

(cart alone) $T =$ _____

(cart with mass) $T =$ _____

Experimental Period

- ① Using the data in Table 3.2, calculate the average time for 5 oscillations with and without the 500 g mass in the cart.
- ② Calculate the period by dividing these times by 5 and record the periods in Table 3.2.

Table 3.2

Trial	Time for 5 Oscillations	Period
1		Without additional mass= _____
2		
3		
4		
5		
Average		
1		With additional mass= _____
2		
3		
4		
5		
Average		

Comparison

Calculate the percent difference between the measured and theoretical values:

(cart alone) % diff = _____

(cart with mass) % diff = _____

Questions

- ① Does the period of oscillation increase or decrease as the mass is increased? Does a more massive cart oscillate faster or slower?
- ② If the initial displacement from equilibrium (amplitude) is changed, does the period of oscillation change? Try it.

Notes:

Experiment 4: Oscillations on an Incline

EQUIPMENT NEEDED:

- | | |
|---|---|
| <ul style="list-style-type: none"> – Dynamics Cart with Mass (ME-9430) – Spring – Base and Support rod (ME-9355) – Mass balance | <ul style="list-style-type: none"> – Dynamics Cart Track with End stop and Pivot clamp – Mass hanger and mass set (ME-934 8) – Stopwatch |
|---|---|

Purpose

The purpose is to measure the period of oscillation of a spring and mass system on an incline at different angles and compare it to the theoretical value.

Theory

For a mass attached to a spring, the theoretical period of oscillation is given by

$$T = 2\pi\sqrt{\frac{m}{k}}$$

where **T** is the time for one complete back-and-forth motion, **m** is the mass that is oscillating, and **k** is the spring constant.

According to Hooke's Law, the force exerted by the spring is proportional to the distance the spring is compressed or stretched, $F = kx$, where **k** is the proportionality constant. The spring constant can be experimentally determined by applying different forces to stretch the spring different distances. When the force is plotted versus distance, the slope of the resulting straight line is equal to **k**.

Procedure

Measurements to Find the Theoretical Period

- ① Use the balance to find the mass of the cart. Record this value at the top of Table 4.1.
- ② Set the cart on the track and attach a spring to one end of the cart by inserting the end of the spring in the hole provided in the cart. Then attach the other end of the spring to the end of the track (See Figure 4.1).
- ③ Incline the track by raising the end of the track that has the spring attached. As the end of the track is raised the spring will stretch. Keep the angle of inclination of the track small enough so the spring is not stretched more than half the length of the track. Measure this angle and record it at the top of Table 4.1.
- ④ Record the equilibrium position in Table 4.1.
- ⑤ Add mass to the cart and record the new position. Repeat this for a total of 5 different masses, being careful not to over-stretch the spring.

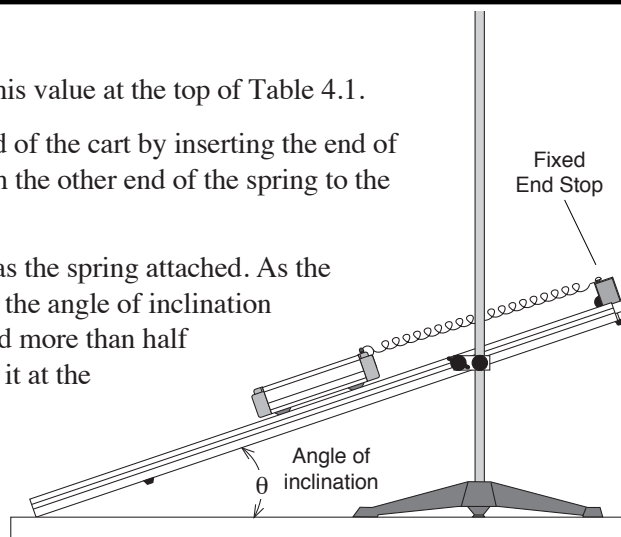

Figure 4.1 Equipment Setup

Table 4.1

Mass of Cart = _____

Equilibrium position = _____

Angle of Incline = _____

Added Mass	Position	Displacement from Equilibrium	Force ($mg \sin\theta$)

Measuring the Experimental Period

- ⑥ Displace the cart from equilibrium a specific distance and let it go. Time 3 oscillations and record the time in Table 4.2.
- ⑦ Repeat this measurement at least 5 times, using the same initial displacement (amplitude).
- ⑧ Change the angle of the incline and repeat Steps 6 and 7.

Calculations

Theoretical Period

- ① Using the data in Table 4.1, calculate the force caused by the additional mass in the cart:
 $F = mg \sin\theta$, where θ is the angle of incline. Plot force versus displacement. Draw the best-fit straight line through the data points and determine the slope of the line. The slope is equal to the effective spring constant, k .

$k =$ _____

- ② Using the mass of the cart and the spring constant, calculate the period using the theoretical formula.

$T =$ _____

Table 4.2**Time for 3 oscillations**

Angle	Trial 1	2	3	4	5	Avg	Period

Experimental Period

- ③ Using the data in Table 4.2, calculate the average time for 3 oscillations.
- ④ Calculate the period by dividing these times by 3 and record the periods in Table 4.2.

Questions

- ① Does the period vary as the angle is changed?
- ② How do the experimental values compare with the theoretical values?
- ③ Does the equilibrium position change as the angle is changed?
- ④ What would be the period if the angle was 90 degrees?

Notes:

Experiment 5: Springs in Series and Parallel

EQUIPMENT NEEDED:

- | | |
|-------------------------------------|----------------------------------|
| – Dynamics Cart with Mass (ME-9430) | – Base and Support rod (ME-9355) |
| – Dynamics Cart Track with End stop | – Mass balance |
| – (2) Springs | – Stopwatch |

Purpose

The purpose is to measure the period of oscillation of springs in series and parallel and compare it to the period of oscillation of one spring.

Theory

For a mass attached to a spring, the theoretical period of oscillation is given by

$$T = 2\pi\sqrt{\frac{m}{k}}$$

where **T** is the time for one complete back-and-forth motion, **m** is the mass that is oscillating, and **k** is the spring constant. If the period of oscillation is measured, the spring constant can be determined:

$$k = \frac{4\pi^2 m}{T^2}$$

When two springs are combined in series or in parallel, the spring constants add in different ways. One possible way to add two spring constants is $k_{\text{effective}} = k + k = 2k$. Another way is

$$k_{\text{effective}} = \frac{1}{k} + \frac{1}{k} = \frac{2}{k}$$

which means that

$$k_{\text{effective}} = \frac{1}{2}k$$

Procedure

Measuring k For a Single Spring

- ① Use the balance to find the mass of the cart. Record this value at the top of Table 5.1.
- ② Set the cart on the track and attach a spring to one end of the cart by inserting the end of the spring in the hole provided in the cart. Then attach the other end of the spring to the end of the track (See Figure 5.1).

► **NOTE:** Remove the leveling feet for this experiment.

- ③ Incline the track by raising the end of the track that has the spring attached. As the end of the track is raised the spring will stretch. Keep the angle of inclination of the track small enough so the spring is not stretched more than half the length of the track.

- ④ Displace the cart from equilibrium a specific distance and let it go. Time 2 oscillations and record the time in Table 5.1. Repeat this measurement at least 5 times, using the same initial displacement (amplitude).

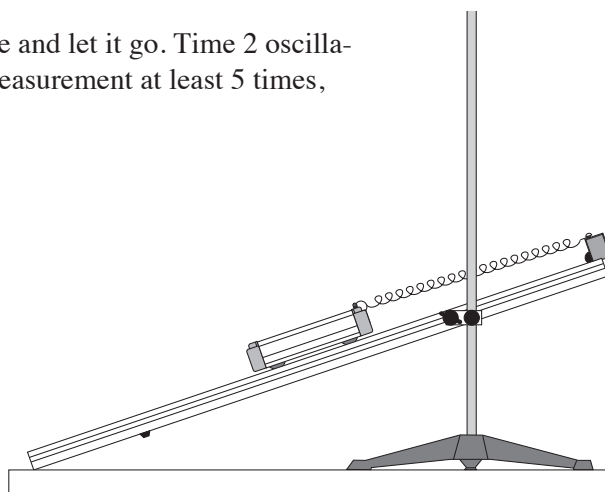

Figure 5.1 Equipment Setup

Measuring the Effective k For Pairs of Springs

- ⑤ Add a second spring in series as shown in Figure 5.2 and repeat Step ④.
⑥ Put the two springs in parallel as shown in Figure 5.3 and repeat Step ④.
⑦ Arrange the springs as shown in Figure 5.4 and repeat Step ④.

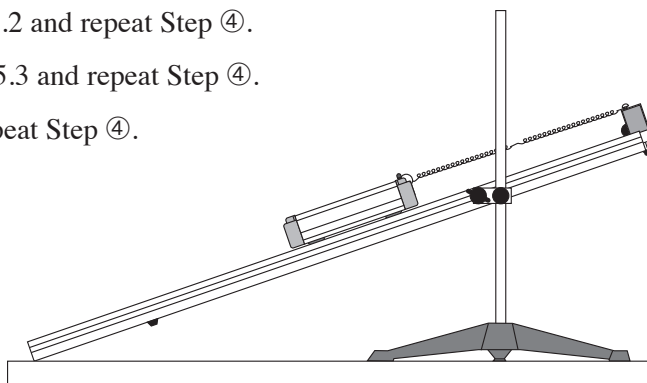

Figure 5.2 Springs in Series

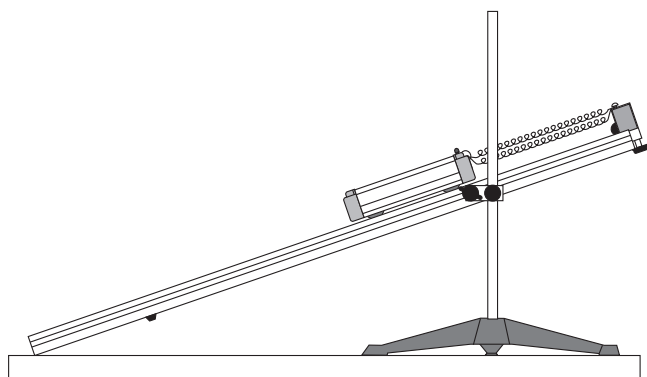

Figure 5.3 Springs in Parallel

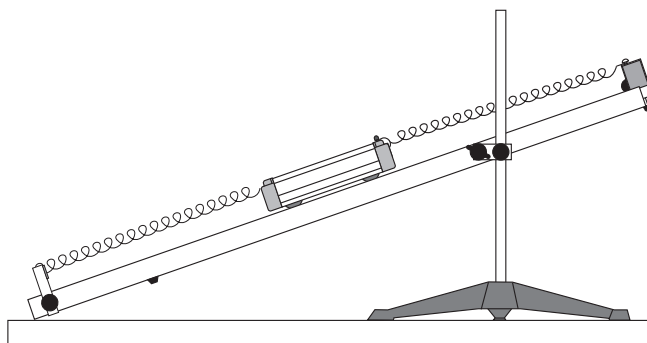

Figure 5.4 Final Spring Arrangement

Calculations

- ① Using the data in Table 5.1, calculate the average time for 2 oscillations.
- ② Calculate the period by dividing these times by 2 and record the periods in Table 5.1.
- ③ Using the periods and the mass of the cart, calculate the effective spring constants.

Mass of Cart = _____

Table 5.1

Time for 2 oscillations

Springs	Trial 1	2	3	4	5	Avg	Period	k
One								
Series								
Parallel								
At Ends								

Questions

- ① Is $k_{\text{effective}} = 2k$ for springs in series or parallel?
- ② Is $k_{\text{effective}} = \frac{1}{2} k$ for springs in series or parallel?
- ③ Is the last spring arrangement series or parallel?

Experiment 6: Newton's Second Law

EQUIPMENT NEEDED:

- Dynamics Cart with Mass (ME-9430)
- Dynamics Cart Track
- Stopwatch

Purpose

The purpose is to show how the acceleration of an object is dependent on force and mass.

Procedure

- ① Level the track by setting the cart on the track to see which way it rolls. Adjust the leveling feet to raise or lower the ends until the cart placed at rest on the track will not move.
- ② To perform each of the following trials, cock the spring plunger on the cart and place the cart at rest at the end of the track with the plunger against the end stop. Then release the plunger by pressing the button on the cart with a ruler. Observe the resulting acceleration. This will be a qualitative measurement.

VARY THE FORCE: Perform the first trial with the spring plunger cocked to the first possible position (the least compression) and then do two more trials increasing the force applied to the cart by increasing the compression of the spring plunger.

VARY THE MASS: For these trials, always cock the spring plunger to the maximum. Observe the relative accelerations of the cart alone and the cart with one mass bar in it. If additional masses are available, use them to increase the mass for additional trials.

Data Analysis

- ① Does the acceleration increase or decrease as the force is increased?
- ② Does the acceleration increase or decrease as the mass is increased?

Question

From the results of this experiment, can you deduce the equation that relates acceleration to mass and force?

Experiment 7: Newton's Second Law II

EQUIPMENT NEEDED:

- | | |
|---|--|
| <ul style="list-style-type: none"> – Dynamics Cart (ME-9430) – Super Pulley with clamp – String – Stopwatch – Mass balance | <ul style="list-style-type: none"> – Dynamics Cart Track – Base and Support rod (ME-9355) – Mass hanger and mass set – Wooden or metal stopping block
(See Procedure Step ③) |
|---|--|

Purpose

The purpose is to verify Newton's Second Law, $\mathbf{F} = \mathbf{ma}$.

Theory

According to Newton's Second Law, $\mathbf{F} = \mathbf{ma}$. \mathbf{F} is the net force acting on the object of mass \mathbf{m} and \mathbf{a} is the resulting acceleration of the object.

For a cart of mass \mathbf{m}_1 on a horizontal track with a string attached over a pulley to a mass \mathbf{m}_2 (see Figure 7.1), the net force \mathbf{F} on the entire system (cart and hanging mass) is the weight of hanging mass, $\mathbf{F} = \mathbf{m}_2\mathbf{g}$, assuming that friction is negligible.

According to Newton's Second Law, this net force should be equal to \mathbf{ma} , where \mathbf{m} is the total mass that is being accelerated, which in this case is $\mathbf{m}_1 + \mathbf{m}_2$. This experiment will check to see if $\mathbf{m}_2\mathbf{g}$ is equal to $(\mathbf{m}_1 + \mathbf{m}_2)\mathbf{a}$ when friction is ignored.

To obtain the acceleration, the cart will be started from rest and the time (\mathbf{t}) it takes for it to travel a certain distance (\mathbf{d}) will be measured. Then since $\mathbf{d} = (1/2)\mathbf{a}\mathbf{t}^2$, the acceleration can be calculated using

$$a = \frac{2d}{t^2} \quad (\text{assuming } a = \text{constant})$$

Procedure

- ① Level the track by setting the cart on the track to see which way it rolls. Adjust the leveling feet to raise or lower the ends until the cart placed at rest on the track will not move.
- ② Use the balance to find the mass of the cart and record in Table 7.1.
- ③ Attach the pulley to the end of the track as shown in Figure 7.1. Place the dynamics cart on the track and attach a string to the hole in the end of the cart and tie a mass hanger on the other end of the string. The string must be just long enough so the cart hits the stopping block before the mass hanger reaches the floor.
- ④ Pull the cart back until the mass hanger reaches the pulley. Record this position at the top of Table 7.1. This will be the release position for all the trials. Make a test run to determine how much mass is required on the mass hanger so that

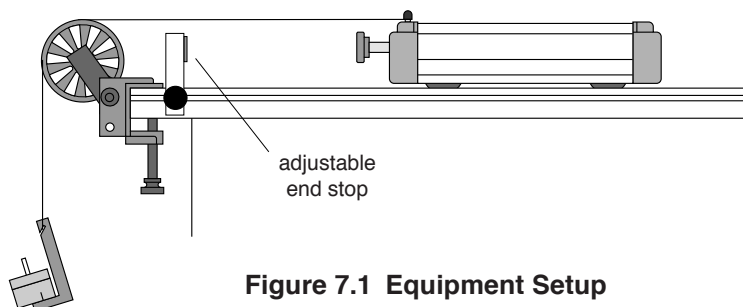

Figure 7.1 Equipment Setup

the cart takes about 2 seconds to complete the run. Because of reaction time, too short of a total time will cause too much error. However, if the cart moves too slowly, friction causes too much error. Record the hanging mass in Table 7.1.

- ⑤ Place the cart against the adjustable end stop on the pulley end of the track and record the final position of the cart in Table 7.1.
- ⑥ Measure the time at least 5 times and record these values in Table 7.1.

Table 7.1

Time

Cart Mass	Hanging Mass	Trial 1	Trial 2	Trial 3	Trial 4	Trial 5	Average Time

- ⑦ Increase the mass of the cart and repeat the procedure.

Initial release Position = _____

Final Position = _____

Total distance (d) = _____

Data Analysis

- ① Calculate the average times and record in Table 7.1.
- ② Calculate the total distance traveled by taking the difference between the initial and final positions of the cart as given in Table 7.1.
- ③ Calculate the accelerations and record in Table 7.2.
- ④ For each case, calculate the total mass multiplied by the acceleration and record in Table 7.2.
- ⑤ For each case, calculate the net force acting on the system and record in Table 7.2.
- ⑥ Calculate the percent difference between F_{NET} and $(m_1+m_2)a$ and record in Table 7.2.

Table 7.2

Cart Mass	Acceleration	$(m_1+m_2)a$	$F_{NET} = m_2g$	% Diff

Questions

- ① Did the results of this experiment verify that $F = ma$?
- ② Considering frictional forces, which force would you expect to be greater: the hanging weight or the resulting total mass times acceleration? Did the results of this experiment consistently show that one was larger than the other?
- ③ Why is the mass in $F = ma$ not just equal to the mass of the cart?
- ④ When calculating the force on the cart using mass times gravity, why isn't the mass of cart included?

Experiment 8: Acceleration Down an Incline

EQUIPMENT NEEDED:

- | | |
|-------------------------------------|-----------------------|
| – Dynamics Cart with Mass (ME-9430) | – Dynamics Cart Track |
| – Base and Support rod (ME-9355) | – Meter stick |
| – Stopwatch | – Graph paper |

Purpose

The purpose is to study how the acceleration of an object down an incline depends on the angle of the incline and to obtain the acceleration due to gravity.

Theory

A cart on an incline will roll down the incline as it is pulled by gravity. The acceleration due to gravity is straight down as shown in Figure 8.1. The component of gravity which is parallel to the inclined surface is $g \sin\theta$, so this is the net acceleration of the cart, neglecting friction.

To measure the acceleration, the cart will be started from rest and the time (t) it takes for it to travel a certain distance (d) will be measured. Then since $d = (\frac{1}{2})at^2$, the acceleration can be calculated using

$$a = \frac{2d}{t^2}$$

Then a plot of acceleration versus $\sin\theta$ should give a straight line with a slope equal to the acceleration due to gravity, g .

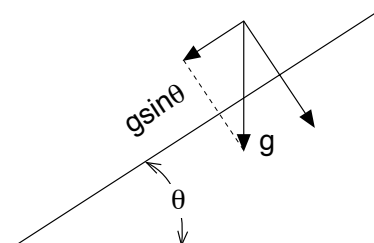
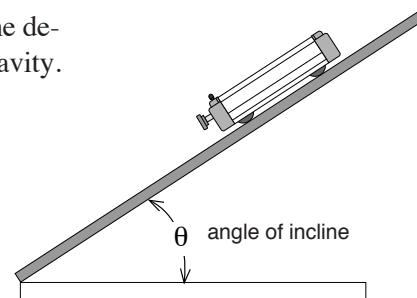

Figure 8.1

Procedure

- ① Set up the track as shown in Figure 8.2, raising the end of the track without an end stop about 10 cm.
- ② Set the cart on the track against the end stop and record this final position of the cart at the top of Table 8.1.
- ③ Pull the cart up to the top of the track and record the initial position where the cart will be released from rest.
- ④ Release the cart from rest and use the stopwatch to time how long it takes the cart to hit the end stop. The person who releases the cart should also operate the stopwatch. Repeat this measurement 10 times (with different people doing the timing). Record all the values in Table 8.1.
- ⑤ Lower the end of the track by 1 cm and measure the time 10 times.
- ⑥ Repeat the experiment for a total of 7 angles,

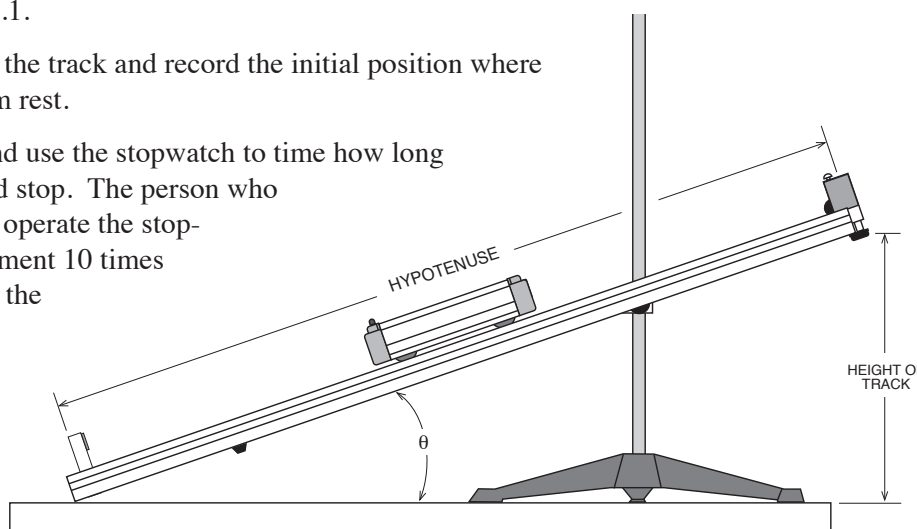

Figure 8.2 Equipment Setup

lowering the track in increments of 1 cm for each new angle.

Table 8.1

		Height of Track						
		10 cm	9 cm	8 cm	7 cm	6 cm	15 cm	4 cm
Time	Trial 1							
	Trial 2							
	Trial 3							
	Trial 4							
	Trial 5							
	Trial 6							
	Trial 7							
	Trial 8							
	Trial 9							
	Trial 10							
	Average							

Initial Position of Cart = _____

Final Position of Cart = _____

Total distance (d) = _____

Data Analysis

- ① Calculate the average time for each angle.
- ② Calculate the total distance traveled by taking the difference between the initial and final positions of the cart as given at the top of Table 8.1.
- ③ Calculate the accelerations using the distance and times and record in Table 8.2.
- ④ Measure the hypotenuse of the triangle formed by the track and use this to calculate $\sin\theta$ for each of the heights.

Table 8.2

Height	Acceleration	$\sin \theta$

Hypotenuse = _____

- ⑤ Plot acceleration versus $\sin\theta$. Draw the best-fit straight line and calculate its slope. (This slope should equal g .) Calculate the percent difference between the slope and g .

slope = _____

% difference = _____

Questions

- ① Does your reaction time cause a greater percentage error for higher or lower angles?
- ② If the mass of the cart is doubled, how are the results affected? Try it.

Notes:

Experiment 9: Conservation of Energy

EQUIPMENT NEEDED:

- | | |
|--|---|
| <ul style="list-style-type: none"> – Dynamics Cart with Mass (ME-9430) – Super Pulley with clamp – Base and Support rod (ME-9355) – String – Mass balance | <ul style="list-style-type: none"> – Dynamics Cart Track – Meter stick – Mass hanger and mass set
(several kilograms) – Graph paper |
|--|---|

Purpose

The purpose is to examine spring potential energy and gravitational potential energy and to show how energy is conserved.

Theory

The potential energy of a spring compressed a distance x from equilibrium is given by $PE = (1/2)kx^2$, where k is the spring constant. According to Hooke's Law, the force exerted by the spring is proportional to the distance the spring is compressed or stretched, $F = kx$, where k is the proportionality constant. Thus the spring constant can be experimentally determined by applying different forces to stretch or compress the spring different distances. When the force is plotted versus distance, the slope of the resulting straight line is equal to k .

The gravitational potential energy gained by a cart as it climbs an incline is given by **potential energy = mgh** , where m is the mass of the cart, g is the acceleration due to gravity, and h is the vertical height the cart is raised. In terms of the distance, d , along the incline, the height is given by $h = d \sin\theta$.

If energy is conserved, the potential energy in the compressed spring will be completely converted into gravitational potential energy.

Procedure

- ① Level the track by setting the cart on the track to see which way it rolls. Adjust the leveling feet to raise or lower the ends until the cart placed at rest on the track will not move.
- ② Use the balance to find the mass of the cart. Record this value in Table 9.2.

Determining the Spring Constant

- ③ Set the cart on the track with the spring plunger against the stopping block as shown in Figure 9.1. Attach a string to the cart and attach the other end to a mass hanger, passing the string over the pulley.
- ④ Record the cart's position in Table 9.1.
- ⑤ Add mass to the mass hanger and record the new position. Repeat this for a total of 5 different masses.

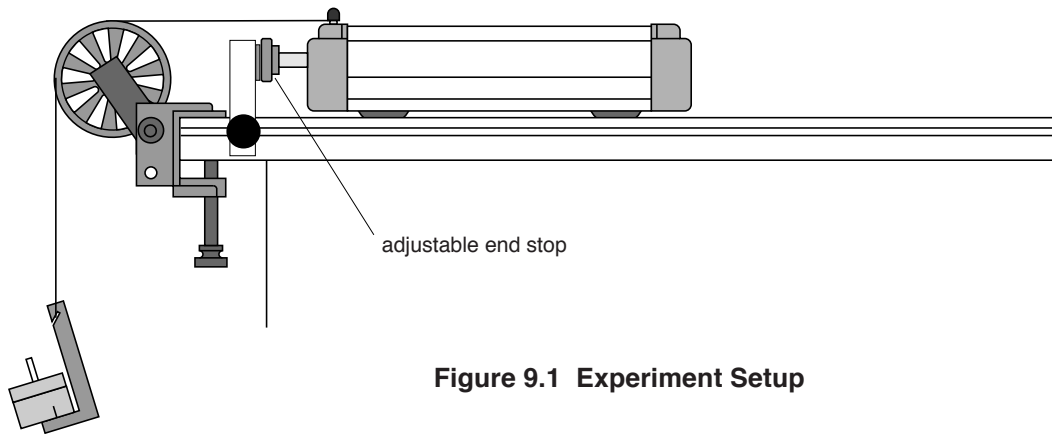

Figure 9.1 Experiment Setup

Table 9.1

Added Mass	Position	Displacement from Equilibrium	Force (mg)

Potential Energy

- ⑥ Remove the leveling feet.
- ⑦ Remove the string from the cart and cock the spring plunger to its maximum compression position. Place the cart against the end stop. Measure the distance the spring plunger is compressed and record this value in Table 9.2.

- ⑧ Incline the track and measure its height and hypotenuse (see Figure 9.2) to determine the angle of the track.

$$\text{angle} = \arcsin \left(\frac{\text{height}}{\text{hypotenuse}} \right)$$

Record the angle in Table 9.2.

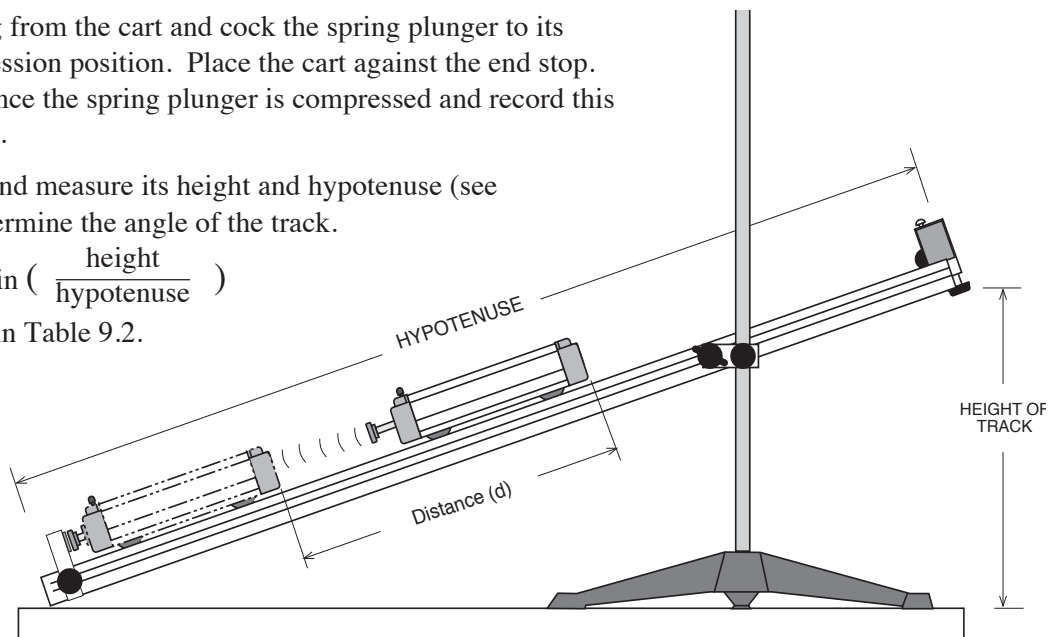

Figure 9.2

- ⑨ Record the initial position of the cart in Table 9.2.
- ⑩ Release the plunger by tapping it with a stick and record the distance the cart goes up the track. Repeat this five times. Record the maximum distance the cart went in Table 9.2.
- ⑪ Change the angle of inclination and repeat the measurements.
- ⑫ Add mass to the cart and repeat the measurements.

Table 9.2
Distance traveled by the cart (d)

Angle	Mass	Trial 1	2	3	4	5	Max	$h = d \sin\theta$

Distance spring is compressed (x) = _____

Initial position of cart = _____

Data Analysis

- ① Using the data in Table 9.1, plot force versus displacement. Draw the best-fit straight line through the data points and determine the slope of the line. The slope is equal to the effective spring constant, k .
 $k =$ _____
- ② Calculate the spring potential energy and record in Table 9.3.
- ③ Calculate the gravitational potential energy for each case and record in Table 9.3.
- ④ Calculate the percent difference between the spring potential energy and the gravitational potential energy.

Table 9.3

Angle/Mass	Spring PE ($\frac{1}{2} kx^2$)	Gravitational PE (mgh)	% Difference

Questions

- ① Which of the potential energies was larger? Where did this “lost” energy go?
- ② When the mass of the cart was doubled, why did the gravitational potential energy remain about the same?

Notes:

Additional Experiment Suggestions

Experiment 11: Conservation of Center of Mass

Set up the track in the configuration shown in Figure 1.1 in Experiment #1 but instead of putting the track directly on the table, place it on the additional mass bar so that the bar acts as a fulcrum. Position the bar so the carts and track are balanced. First use two carts of equal mass. Press the cocked plunger and watch the carts move to the ends of the track. Since the center of mass of the system does not move, the track will remain balanced.

Then repeat this procedure using carts of unequal mass.

Experiment 12: Oscillation Modes of Two Carts and Three Springs

Place two carts of equal mass on the track. Attach a spring between the two carts and connect each cart to their respective ends of the track with springs. Pull the carts away from each other and release and observe the mode of oscillation. Then displace both carts in the same direction initially and observe.

Add a mass bar to one cart and repeat.

Experiment 13: Newton's Second Law III

Repeat **Experiment 7** with the track inclined so the pulley is on the high end and the cart accelerates up the incline.

Experiment 14: Damped Motion

Incline the track with the end stop at the bottom. Release the cart from a measured distance up the inclined track. The spring plunger should be unlocked and directed toward the bottom of the incline so the cart will rebound. On each rebound, when the cart reaches its peak, record the time and position. A plot of amplitude versus time can be made.

Experiment 15: Rocket Cart with Balloon

Attach an untied inflated balloon to the cart with the neck of the balloon directed out the back of the cart. Let the air propel the cart.

Experiment 16: Oscillation Modes of Three Carts and Four Springs

(For the ME-9459 system)

Place three carts of equal mass on the track. Attach a spring between the carts and connect the end carts to their respective ends of the track with springs.

Displace the two end carts away from the middle cart and release and observe the mode of oscillation.

Displace the two carts on the left away from the cart on the right and release and observe the mode of oscillation.

Displace the middle cart and release and observe the mode of oscillation.

Experiment 17: Multiple Elastic Collisions

(For the ME-9459 system)

Use two Collision Carts and one Dynamics Cart. Try this experiment with carts of the same mass and then with carts of different masses. Set the three carts on the track with the Dynamics Cart on the right end with its magnetic bumper oriented toward the Collision Carts. Push the left Collision Cart into the middle cart, which in turn will collide with the right cart. Note the resulting final velocities of each cart.

Experiment 18: Multiple Inelastic Collisions

(For the ME-9459 system)

Use two Collision Carts and one Dynamics Cart with its magnets removed. Alternatively, two Dynamics Carts and one Collision Cart may be used. Try this experiment with carts of the same

mass and then with carts of different masses. Set the three carts on the track with the carts arranged so that the Velcro bumpers will collide without magnets to push them apart. Push the left cart into the middle cart, which in turn will collide with the right cart. The carts will all stick together. Note the resulting final velocity of the carts.

Experiment 19: Rocket Staging

Use three or more Dynamics Carts (with plungers) to simulate a rocket expelling fuel. Push the plungers in on each cart and attach the carts together in a line on the 7.5' track. Tape can be used to lightly attach the carts to each other or Velcro can be added to the bumpers. Position the carts at one end of the track. The lead cart represents the rocket and the rest of the carts are fuel. Use a meter stick to release the plungers in succession by striking the plunger-release of each cart, beginning with the last fuel cart (furthest from the rocket cart). As each plunger is released, each cart will separate from the rest, one at a time. Note the final speed of the rocket cart compared to its speed when all the fuel is dumped at once.

Experiment 20: Longitudinal Wave

Use six or more Collision Carts on the 7.5 foot track with the adjustable end stops installed at the ends of the track with the magnetic side of the end stops toward the center of the track. Start a longitudinal pulse by displacing one of the carts. The carts will rebound off each other and the end stops. Oscillate the end cart to keep a longitudinal wave going down the track.

Teacher's Guide

Experiment 1: Conservation of Energy in Explosions

Notes on Data Analysis

M1	M2	Position	X1	X2	X1/X2	M2/M1
497.5	500.7	181.0	42.0	41.5	1.01	1.01
497.5	996.4	195.0	56.0	27.5	2.04	2.00
497.5	1494.9	201.5	62.5	21.0	2.98	3.00
995.7	1494.9	189.0	50.0	33.5	1.49	1.50

Answers to Questions

- ① Momentum is conserved in each case.
- ② As shown in this lab, the momentum of each cart is the same.
- ③ $KE_2 = \frac{m_1}{m_2} KE_1$

The lighter cart will have a higher kinetic energy.

- ④ The starting position does not depend on which cart has the plunger cocked. During the “explosion”, the momentum of the carts will be affected by the fact that the plunger is moving at a different velocity than either cart. However, since each plunger eventually ends up moving at the same speed as the cart it is on, there is no difference once the carts are separated.

Experiment 2: Conservation of Momentum in Collisions

► **NOTE:** Without some method of actually measuring the velocities of the carts, this lab should be used for qualitative analysis only.

Part I

- Since the carts have the same mass, they will exchange velocity in each case.
- The momentum transfer will be proportional to the ratio of the cart masses.

Questions

- Each cart loses its momentum. The *total* momentum is unchanged, because the total momentum is zero both before and after the collision.
- The total momentum in this case is still zero both before and after the collision.

Experiment 3: Simple Harmonic Oscillator

Notes on Procedure

- ⑥ For best results, make sure that the springs are neither over-stretched nor hanging loose. For these tests, we used 10-50g masses only.

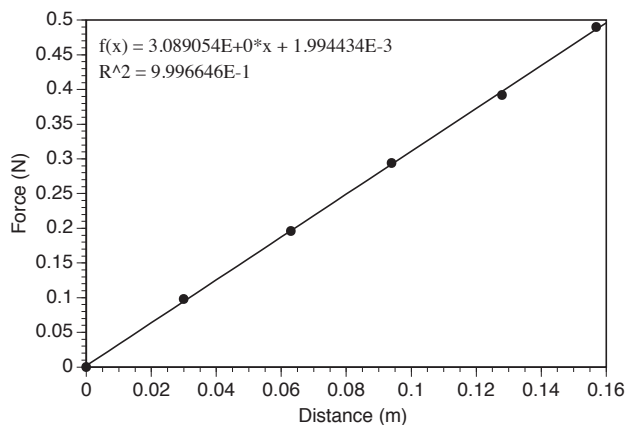

Notes on Calculations

- ① The spring constant $k = 3.089 \text{ N/m}$ for the springs used here. This value will vary from spring to spring.
- ② Theoretical values will vary, depending on the value for k and for m . For best results, measure the carts rather than assume their weight to be the stated 500g.

Notes on Comparison

The percent difference between experimental and theoretical values should be less than 2%, and it is not unusual to obtain errors of less than 0.5%.

Notes on Questions

- ① The period of oscillation increases with mass. The more massive cart oscillates slower.
- ② The period is not changed, as long as the initial displacement does not exceed the linear region of the spring. You will notice a slight difference if the displacement is enough to permanently deform the spring.

Experiment 4: Oscillations on an Incline

Notes on Procedure

The angle of inclination of the track should be between 5 and 15° for best results. You may want to measure the spring constant by hanging masses directly from the spring (vertically) without the cart. This is a better method than the one described in the experiment guide.

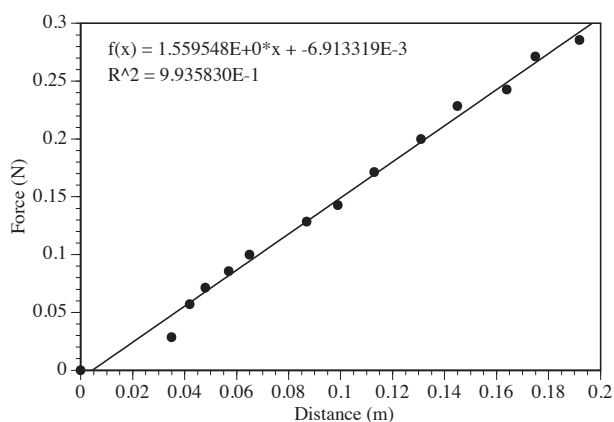

Notes on Calculations

- ① The spring constant $k = 1.5595$ for the spring tested here. Actual spring constant will vary, although it should be close to 1.5 for the springs supplied with this apparatus.
- ② Theoretical values will vary, depending on the value for k and for m . For best results, measure the carts rather than assume their weight to be the stated 500g.

Notes on Questions

- ① The period does not vary significantly as the angle changes. There is some variation due to nonlinearity in the spring; as the spring is extended at greater angles, the force “constant” is not constant. The contribution due to friction changes with angle, as well.
- ② The experimental results should agree with theory to within 2%, although it is not unusual to find agreement within less than 1%.
- ③ The equilibrium position changes as the angle is changed.
- ④ The period would be the same at 90° , as long as the spring was not overstretched. NOTE: hanging the PASCO dynamics cart from the spring supplied with this equipment will overextend the spring.

Experiment 5: Springs in Series and Parallel

Keep the angle of the track low, especially if you are using a short (1.2m) track. Otherwise, the carts will go off the end of the track when the springs are in series.

Notes on Calculations

The two springs used for this experiment had spring constants of 1.53 and 1.60.

- In series, the spring constant was 0.76. ($k/2$)
- In parallel, the spring constant was 3.12 ($2k$)
- The spring constant was 3.06 ($2k$) when the springs were attached to the ends of the cart.

Notes on Questions

- ① The effective spring constant is $2k$ for springs in parallel.
- ② The effective spring constant is $k/2$ for springs in series.
- ③ The springs are effectively in parallel when they are attached to opposite ends of the cart.

Experiment 6: Newton's Second Law

This lab is intended to be a qualitative lab only. For a quantitative analysis of Newton's second law, see experiment 7.

Notes on Data Analysis

- ① Acceleration increases with force
- ② Acceleration decreases with mass.

Notes on Questions

$$F = ma$$

Experiment 7: Newton's Second Law II

If the mass used to accelerate the cart is too low, friction will be a very significant source of error. If it is too high, then the time will be short and accurate measurement will be difficult. It would be best for this lab to use a photogate timing system, such as the PASCO ME-9215.

Notes on Questions

- ① The results of this experiment generally show that $F = ma$. Errors can be high, due to friction and timing inaccuracy.
- ② The force of the hanging weight is larger than the total mass times acceleration. The difference between the two is the force of friction.
- ③ The hanging mass is accelerating at the same rate as the cart, so its mass must be considered as well as that of the cart.
- ④ The cart is on a level track, so it is not accelerated by gravity.

Experiment 8: Acceleration Down an Incline

Data Analysis

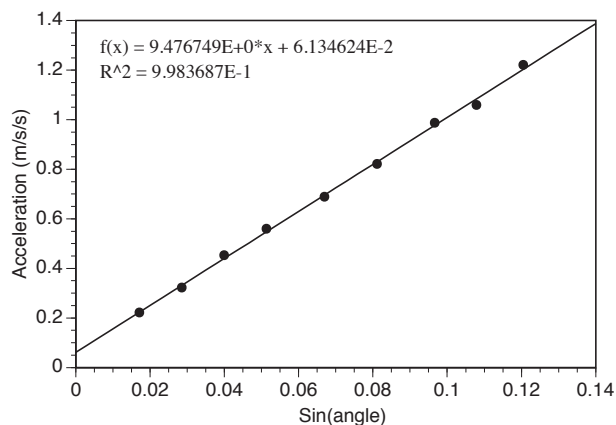

The value of the slope will be slightly lower than 9.8, due to friction. (Our value 3.3% low.)

Notes on Questions

- ① Assuming that reaction time relatively constant, the percent error due to reaction time would be greater for shorter times and higher angles.
- ② Changing the mass of the cart will affect the results slightly due to changing frictional characteristics.

Experiment 9: Conservation of Energy

Analysis

①

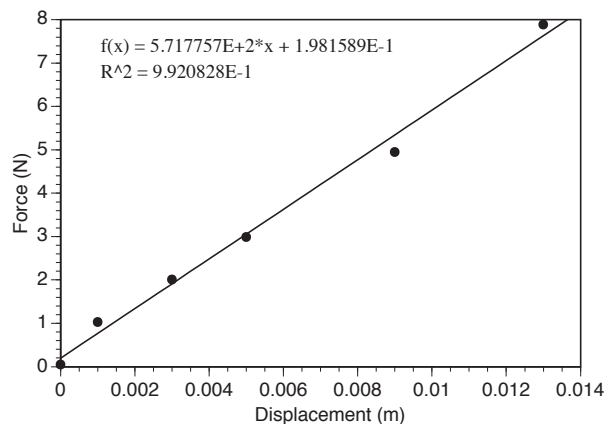

Notes on Questions

- ① The initial spring potential energy is larger. (Generally. There are experimental errors, which can make the gravitational energy appear larger than the initial spring potential.) The “lost” energy goes into friction.
- ② Why not? The increased mass will mean that the cart does not travel as high, but the final gravitational potential energy will be the same.

②-④

k = 572 Spring PE = 0.193336

Angle	Mass	dmax (cm)	h (m)	mgh	%diff
14.57	0.4971	15.1	0.0380	0.1851	-4.28%
11.07	0.4971	19.5	0.0374	0.1824	-5.66%
11.07	0.9926	10.1	0.0194	0.1886	-2.43%
3.026	0.9926	39.0	0.0206	0.2003	3.58%
3.026	0.4971	75.1	0.0396	0.1931	-0.11%

Technical Support

Feedback

If you have any comments about the product or manual, please let us know. If you have any suggestions on alternate experiments or find a problem in the manual, please tell us. PASCO appreciates any customer feedback. Your input helps us evaluate and improve our product.

To Reach PASCO

For technical support, call us at 1-800-772-8700 (toll-free within the U.S.) or (916) 786-3800.

fax: (916) 786-3292

e-mail: techsupp@pasco.com

web: www.pasco.com

Contacting Technical Support

Before you call the PASCO Technical Support staff, it would be helpful to prepare the following information:

- ▶ If your problem is with the PASCO apparatus, note:
 - Title and model number (usually listed on the label);
 - Approximate age of apparatus;
 - A detailed description of the problem/sequence of events (in case you can't call PASCO right away, you won't lose valuable data);
 - If possible, have the apparatus within reach when calling to facilitate description of individual parts.
- ▶ If your problem relates to the instruction manual, note:
 - Part number and revision (listed by month and year on the front cover);
 - Have the manual at hand to discuss your questions.

