

Includes
Teacher's Notes
and
Typical
Experiment Results



**Instruction Manual and
Experiment Guide for the
PASCO scientific Model
ME-6830/ME-6831**

012-05375B
2/99

Ballistic Pendulum / Projectile Launcher

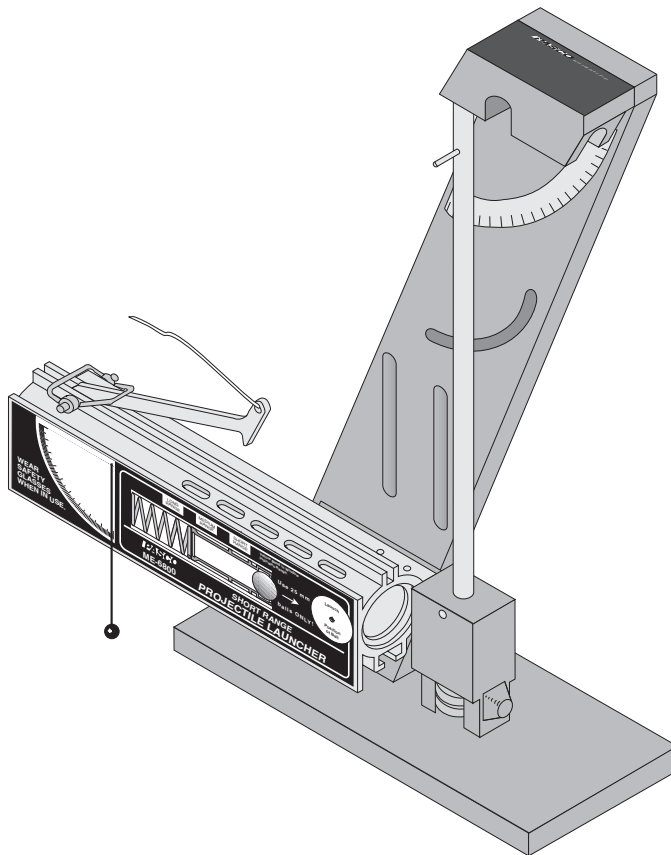

© 1993 PASCO scientific

\$10.00

PASCO[®]
scientific

10101 Foothills Blvd. • Roseville, CA 95747-7100
Phone (916) 786-3800 • FAX (916) 786-8905 • www.pasco.com

better
ways to
teach science

Table of Contents

Section	Page
Copyright, Warranty, and Equipment Return	ii
Introduction	1
Equipment	2
General Operation Of The Projectile Launcher	3
Theory of operation for Ballistic Pendulum	4
Installation Of The Optional Photogate Bracket	6
Installing the 2-Dimensional Collision Attachment	7
Expectations For The Projectile Launcher	7
Expectations for the Ballistic Pendulum	7
Experiments	
1. Projectile Motion	9
2. Projectile Motion Using Photogates	13
3. Projectile Range versus Angle	17
4. Projectile Path	21
5. Conservation of Energy	25
6. Conservation of Momentum in Two Dimensions	29
7. Varying Angle to Maximize Height on a Wall	33
8. Ballistic Pendulum approximate method	35
9. Ballistic Pendulum exact method	37
10. Demo: Do 30° and 60° Give Same Range?	39
11. Demo: Simultaneously Shoot Two Balls Horizontally at Different Speeds	41
12. Demo: Shoot through Hoops	43
13. Demo: Elastic / Inelastic Collisions	45
Teachers Guide	46
Technical Support	Back Cover

Copyright, Warranty and Equipment Return

Please—Feel free to duplicate this manual subject to the copyright restrictions below.

Copyright Notice

The PASCO scientific 012-05375 manual is copyrighted and all rights reserved. However, permission is granted to non-profit educational institutions for reproduction of any part of the Ballistic Pendulum/Projectile Launcher manual providing the reproductions are used only for their laboratories and are not sold for profit. Reproduction under any other circumstances, without the written consent of PASCO scientific, is prohibited.

Limited Warranty

PASCO scientific warrants the product to be free from defects in materials and workmanship for a period of one year from the date of shipment to the customer. PASCO will repair or replace, at its option, any part of the product which is deemed to be defective in material or workmanship. The warranty does not cover damage to the product caused by abuse or improper use. Determination of whether a product failure is the result of a manufacturing defect or improper use by the customer shall be made solely by PASCO scientific. Responsibility for the return of equipment for warranty repair belongs to the customer. Equipment must be properly packed to prevent damage and shipped postage or freight prepaid. (Damage caused by improper packing of the equipment for return shipment will not be covered by the warranty.) Shipping costs for returning the equipment, after repair, will be paid by PASCO scientific.

Credits

Author: Ann Hanks and Eric Ayers

Equipment Return

Should the product have to be returned to PASCO scientific, for whatever reason, notify PASCO scientific by letter, phone, or fax BEFORE returning the product. Upon notification, the return authorization and shipping instructions will be promptly issued.

► NOTE: NO EQUIPMENT WILL BE ACCEPTED FOR RETURN WITHOUT AN AUTHORIZATION.

When returning equipment for repair, the units must be packed properly. Carriers will not accept responsibility for damage caused by improper packing. To be certain the unit will not be damaged in shipment, observe the following rules:

- ① The carton must be strong enough for the item shipped.
- ② Make certain there is at least two inches of packing material between any point on the apparatus and the inside walls of the carton.
- ③ Make certain that the packing material can not shift in the box, or become compressed, thus letting the instrument come in contact with the edge of the box.

Address: PASCO scientific
10101 Foothills Blvd.
Roseville, CA 95747-7100

Phone: (916) 786-3800

FAX: (916) 786-8905

email: techsupp@pasco.com

Introduction

The PASCO ME-6830/ME-6831 Ballistic Pendulum/Projectile Launcher (BPPL) has been designed for projectile experiments and demonstrations as well as the classic Ballistic Pendulum experiments. The only additional equipment required is a C-clamp for clamping the launcher to a table. The features of the Ballistic Pendulum/Projectile Launcher include:

- **LAUNCH AT ANY ANGLE:** Balls can be launched at any angle from zero to 90 degrees measured from the horizontal. The angle is easily adjusted using thumb screws. The built-in protractor and plumb-bob on the side of the launcher give a convenient and accurate way of determining the angle of inclination.
 - **THREE RANGE SETTINGS:** There are three ranges from which to choose. For the Short Range Projectile Launcher these three ranges are approximately 1.2 meters, 3 meters, and 5 meters, when the angle is 45 degrees. For the Long Range Demonstration Projectile Launcher, the three ranges are approximately 2.5 meters, 5 meters, and 8 meters. The difference between these two versions of the Projectile Launcher is the strength of the spring. The long range version is intended for large classroom demonstrations and should not be used with the Ballistic Pendulum base.
 - **FIXED ELEVATION INDEPENDENT OF ANGLE:** The Projectile Launcher pivots at the muzzle end so the elevation of the ball as it leaves the barrel does not change as the angle is varied. The base has three sets of slots. The top curved slot is used when it is desired to change the angle and the center two slots are used when it is desired to shoot horizontally only. The bottom mounting holes are for use with the Ballistic Pendulum experiment.
 - **REPEATABLE RESULTS:** There is no spin on the ball since the piston keeps the ball from rubbing on the walls as it travels up the barrel. The sturdy base can be secured to a table with a C-clamp (not included) so there is very little recoil. The trigger is pulled with a string to minimize any misalignment caused by other methods of trigger release.
- **IMPORTANT:** Experimental results can be further improved by making sure that the ball does not stick to the blue vibration damping ring prior to being launched. This is particularly critical for the long range setting and for launching angles above 30°. To assure the ball does not stick to the ring, push it gently with a pencil from the back of the barrel.
- **BARREL SIGHTS AND SAFETY PRECAUTIONS:** The sights for aiming the Projectile Launcher can be viewed from the back of the launcher by looking through the back end of the barrel.
- **WARNING:** Never look down the front of the barrel because it may be loaded. To see if the ball is in the barrel and to check whether the Projectile Launcher is cocked, look at the slots in the side of the barrel. The yellow indicator seen through the side slot indicates the position of the piston. The ball can also be seen through these slots when it is in the piston.
- **COMPUTER COMPATIBLE:** Photogates can be attached with the ME-6821 Photogate Mounting Bracket to connect the Projectile Launcher to a computer for measuring the muzzle speed. Also, a photogate at the muzzle and an ME-6810 Time-of-Flight Accessory can be used to time the flight of the ball.
 - **COMPACT STORAGE:** The Projectile Launcher stores away in a small space. The ramrod attaches to the Projectile Launcher with Velcro® and the launcher can be turned vertically so it takes up the minimum amount of space on the shelf.
 - **RELIABLE BALL-CATCHER MECHANISM:** The sensitive spring-loaded barb-type catch on the pendulum will catch balls with a large range of momenta. In addition, the ball is held in line with the pendulum rod for best accuracy.
 - **REMOVABLE PENDULUM:** All moving parts of the pendulum may be removed so that the mass and the center of mass can be easily determined. In addition, the pendulum can be reversed to compare the effects of inelastic and elastic collisions.
 - **VARIABLE-MASS PENDULUM:** Masses can be added to the bottom of the pendulum so that meaningful measurements can be taken with either heavy or lightweight balls, over a wide range of velocities.

Equipment

The following is a description of the equipment that is included with various models of the Ballistic Pendulum/Projectile Launcher.

The ME-6831 Ballistic Pendulum includes the following:

- Ballistic Pendulum base (assembled)
- (2) steel balls

In addition, the ME-6830 Ballistic Pendulum/Projectile Launcher includes:

- Short Range Launcher
- ramrod (Attached with Velcro® to stand)
- collision attachment
- (3) plastic balls
- (2) pendulum brass masses
- (2) safety goggles

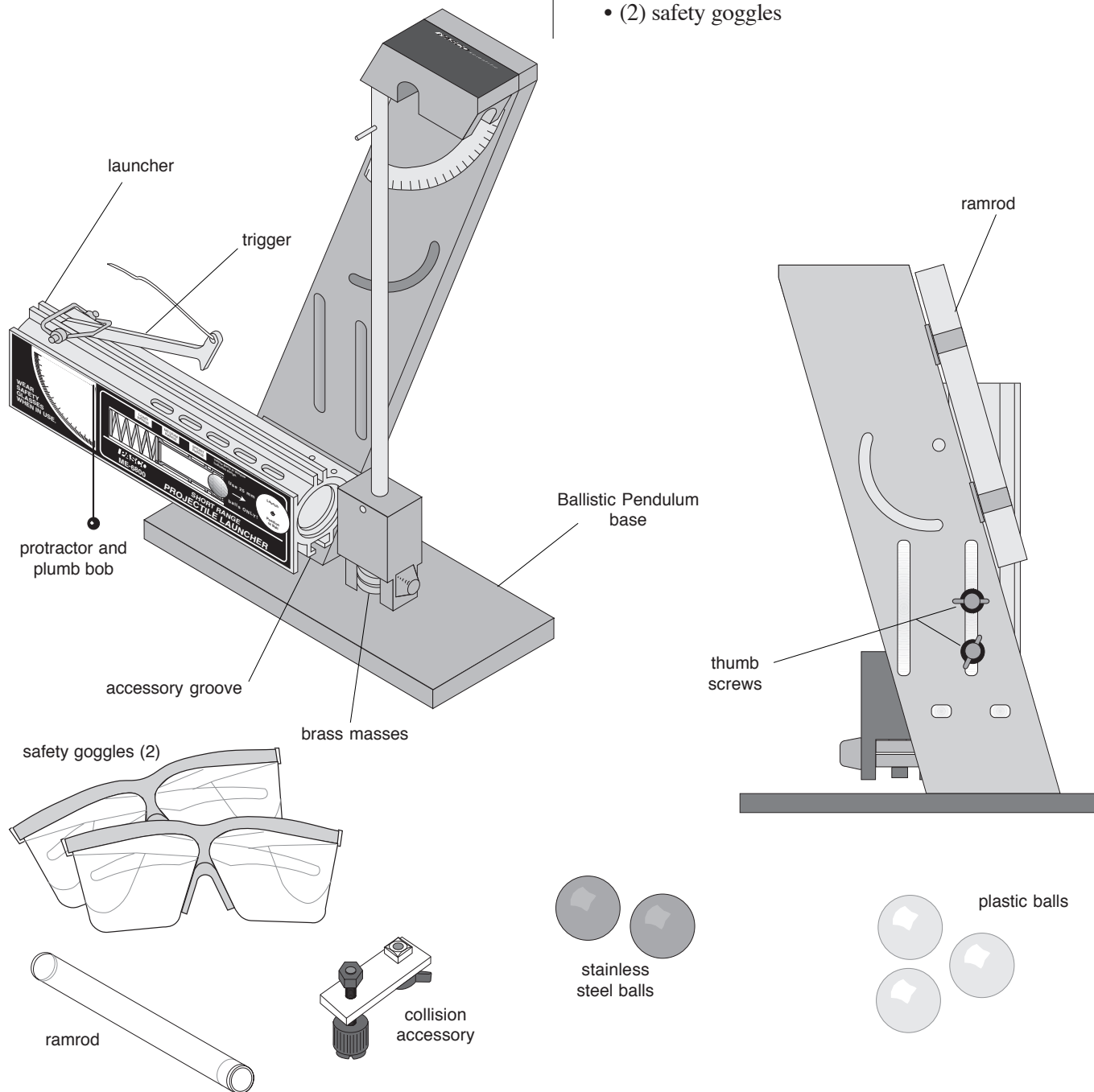

General Operation of the Projectile Launcher

① Ready

- Always wear safety goggles when you are in a room where the Projectile Launcher is being used.
- For Projectile Launcher experiments, the base of the Ballistic Pendulum/Projectile Launcher must be clamped to a sturdy table using the clamp of your choice. When clamping to the table, it is often desirable to have the label side of the Launcher even with one edge of the table so a plumb bob can be used to locate the position of the muzzle with respect to the floor.
- The Projectile Launcher can be mounted to the bracket using the curved slot when it is desired to change the launch angle. It can also be mounted to the center two slots in the base if you are only going to launch horizontally, such as into a Dynamics Cart.

② Aim

- The angle of inclination above the horizontal is adjusted by loosening both thumb screws and rotating the Launcher to the desired angle as indicated by the plumb bob and protractor on the side of the Launcher. When the angle has been selected, both thumb screws are tightened.
- You can bore-sight at a target (such as in the Monkey-Hunter demonstration) by looking through the Launcher from the back end when the Launcher is not loaded. There are two sights inside the barrel. Align the centers of both sights with the target by adjusting the angle and position of the Launcher.

③ Load

- Always cock the piston with the ball in the piston. Damage to the piston may occur if the ramrod is used without the ball.
- Place the ball in the piston. Remove the ramrod from its Velcro® storage place on the base. While viewing the range-setting slots in the side of the launcher, push the ball down the barrel with the ramrod until the trigger catches the piston at the desired range setting.

- Remove the ramrod and place it back in its storage place on the base.
- When the Projectile Launcher is loaded, the yellow indicator is visible in one of the range slots in the side of the barrel and the ball is visible in another one of the slots in the side of the barrel. To check to see if the Launcher is loaded, always check the side of the barrel. Never look down the barrel!

④ Shoot

- Before launching the ball, make certain that no person is in the way.
- To shoot the ball, pull straight up on the lanyard (string) that is attached to the trigger. It is only necessary to pull it about a centimeter.
- The spring on the trigger will automatically return the trigger to its initial position when you release it.

⑤ Maintenance and Storage

- No special maintenance of the Projectile Launcher is required.
- Do not oil the launcher!!
- To store the launcher in the least amount of space, adjust its angle to 90 degrees. If the Photogate Mounting Bracket and Photogates are attached to the launcher, the bracket can be slid back along the barrel with the photogates still attached.

Ballistic Pendulum - Theory

Overview

The ballistic pendulum is a classic method of determining the velocity of a projectile. It is also a good demonstration of some of the basic principles of physics.

The ball is fired into the pendulum, which then swings up a measured amount. From the height reached by the pendulum, we can calculate its potential energy. This potential energy is equal to the kinetic energy of the pendulum at the bottom of the swing, just after the collision with the ball.

We cannot equate the kinetic energy of the pendulum after the collision with the kinetic energy of the ball before the swing, since the collision between ball and pendulum is inelastic and kinetic energy is not conserved in inelastic collisions. Momentum is conserved in all forms of collision, though; so we know that the momentum of the ball before the collision is equal to the momentum of the pendulum after the collision. Once we know the momentum of the ball and its mass, we can determine the initial velocity.

There are two ways of calculating the velocity of the ball. The first method (approximate method) assumes that the pendulum and ball together act as a point mass located at their combined center of mass. This method does not take rotational inertia into account. It is somewhat quicker and easier than the second method, but not as accurate.

The second method (exact method) uses the actual rotational inertia of the pendulum in the calculations. The equations are slightly more complicated, and it is necessary to take more data in order to find the moment of inertia of the pendulum; but the results obtained are generally better.

Please note that the subscript "cm" used in the following equations stands for "center of mass."

Approximate Method

Begin with the potential energy of the pendulum at the top of its swing:

$$\Delta PE = Mg\Delta h_{cm}$$

Where M is the combined mass of pendulum and ball, g is the acceleration of gravity, and Δh is the change in height. Substitute for the height:

$$\Delta h = R(1 - \cos \theta)$$

$$\Delta PE = MgR_{cm}(1 - \cos \theta)$$

Here R_{cm} is the distance from the pivot point to the center of mass of the pendulum/ball system. This potential energy is equal to the kinetic energy of the pendulum immediately after the collision:

$$KE = \frac{1}{2} Mv_p^2$$

The momentum of the pendulum after the collision is just

$$P_p = Mv_p,$$

which we substitute into the previous equation to give:

$$KE = \frac{P_p^2}{2M}$$

Solving this equation for the pendulum momentum gives:

$$P_p = \sqrt{2M(KE)}$$

This momentum is equal to the momentum of the ball before the collision:

$$P_b = mv_b.$$

Setting these two equations equal to each other and replacing KE with our known potential energy gives us:

$$mv_b = \sqrt{2M^2 g R_{cm}(1 - \cos \theta)}$$

Solve this for the ball velocity and simplify to get:

$$v_b = \frac{M}{m} \sqrt{2gR_{cm}(1 - \cos \theta)}$$

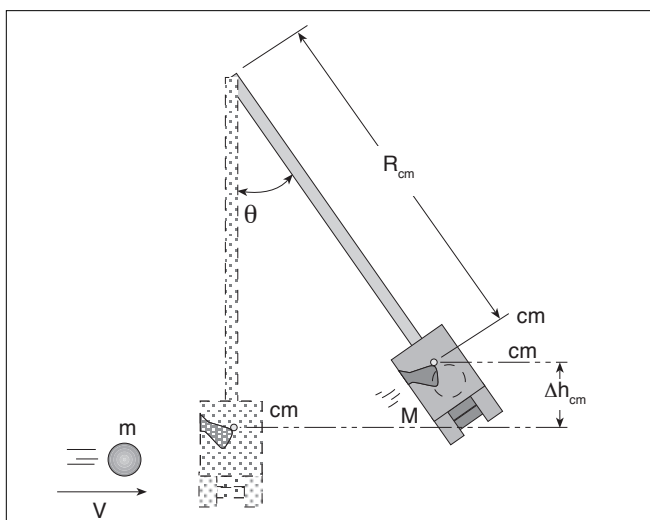

Figure 1

Exact Method

The potential energy is found in a way identical to the way shown previously:

$$\Delta PE = MgR_{cm}(1 - \cos\theta)$$

For the kinetic energy, we use the equation for angular kinetic energy instead of linear, and substitute into it the equation for angular momentum.

$$KE = \frac{1}{2} I\omega^2$$

$$L_p = I\omega$$

$$KE = \frac{L_p^2}{2I}$$

Here I is the moment of inertia of the pendulum/ball combination, and ω is the angular velocity immediately after the collision.

As we did previously, solve this last equation for angular momentum:

$$L_p = \sqrt{2I(KE)}$$

This angular momentum is equal to the angular momentum of the ball before the collision, as measured from the pendulum pivot point.

$$L_b = mR_b^2\omega = mR_b v$$

R_b is the distance from the pendulum pivot to the ball. (This radius is *not* in general equal to R_{cm} , which is the distance from the pivot point to the center of mass for the pendulum/ball system.)

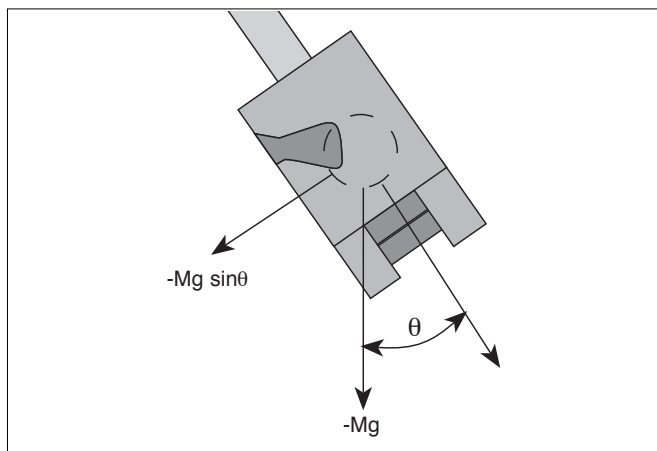

Figure 2

These two angular momenta are equal to each other, so:

$$mR_b v = \sqrt{2IMgR_{cm}(1 - \cos\theta)}$$

Solve for v :

$$v = \frac{1}{mR_b} \sqrt{2IMgR_{cm}(1 - \cos\theta)}$$

Now we need to find I , the moment of inertia of the pendulum and ball. To do this, we start with the rotational equivalent of Newton's second law,

$$\tau = I\alpha$$

where τ is torque, I is moment of inertia, and α is angular acceleration. The force on the center of mass of the pendulum is just Mg , and the component of that force directed towards the center of the pendulum swing is (see figure 2):

$$F = -Mg \sin\theta$$

The torque on the pendulum is thus:

$$I\alpha = -R_{cm}Mg \sin\theta$$

For small angles θ , $\sin\theta \approx \theta$, so if we make this substitution and solve for α we get:

$$\alpha \approx -\frac{MgR_{cm}}{I} \theta$$

This angular equation is in the same form as the equation for linear simple harmonic motion:

$$\alpha = -\frac{k}{m}x = -\omega^2 x$$

So if we compare these two equations, linear and angular, we can see that the pendulum exhibits simple harmonic motion, and that the square of the angular frequency (ω^2) for this motion is just:

$$\omega^2 = \frac{MgR_{cm}}{I}$$

Solving this for I gives us the desired result:

$$I = \frac{MgR_{cm}}{\omega^2} = \frac{MgR_{cm}T^2}{4\pi^2}$$

Where T is the period of the pendulum.

► **NOTE:** We have made a small-angle approximation to find this equation for I ; but I does not depend on θ . This means that we must measure the period T using small oscillations; but once we have calculated I with that period, we may use that value of I regardless of the amplitude reached during other parts of the experiment.

Installing the Photogate Mounting Bracket

The PASCO Model ME-6821 Photogate Mounting Bracket is an optional accessory to the PASCO Projectile Launchers. It attaches to the front of the launcher and holds one or two photogates in parallel for measuring the muzzle velocity of the ball.

Setup procedure

- ① Loosen the thumbscrew of the Photogate Mounting Bracket.
- ② Align the bracket assembly with the front of the Projectile Launcher and slide the square nut down the groove of the barrel until the dowel pin enters the groove.

(The dowel pin acts as an alignment guide and must enter the groove for proper alignment of the bracket.)

► **NOTE:** The flat side of the square nut must face the inside of the projectile launcher groove as shown.

- ③ Slide the Photogate Mounting Bracket to the desired position and tighten the thumbscrew to secure.
- ④ Unscrew the small rod clamp from the Photogate Head. (Save the clamp assembly for later use.)
- ⑤ Attach each photogate to the Mounting Bracket with one of the 6-32x3/8" nylon thumbscrews included with the bracket assembly.
- ⑥ Slide the Mounting Bracket back until the photogate nearest to the barrel is as close to the barrel as possible without blocking the beam.
- ⑦ When storing the launcher, the Photogate Mounting Bracket need not be removed. It can be slid back along the barrel with or without the photogates in place, making as compact a package as possible.

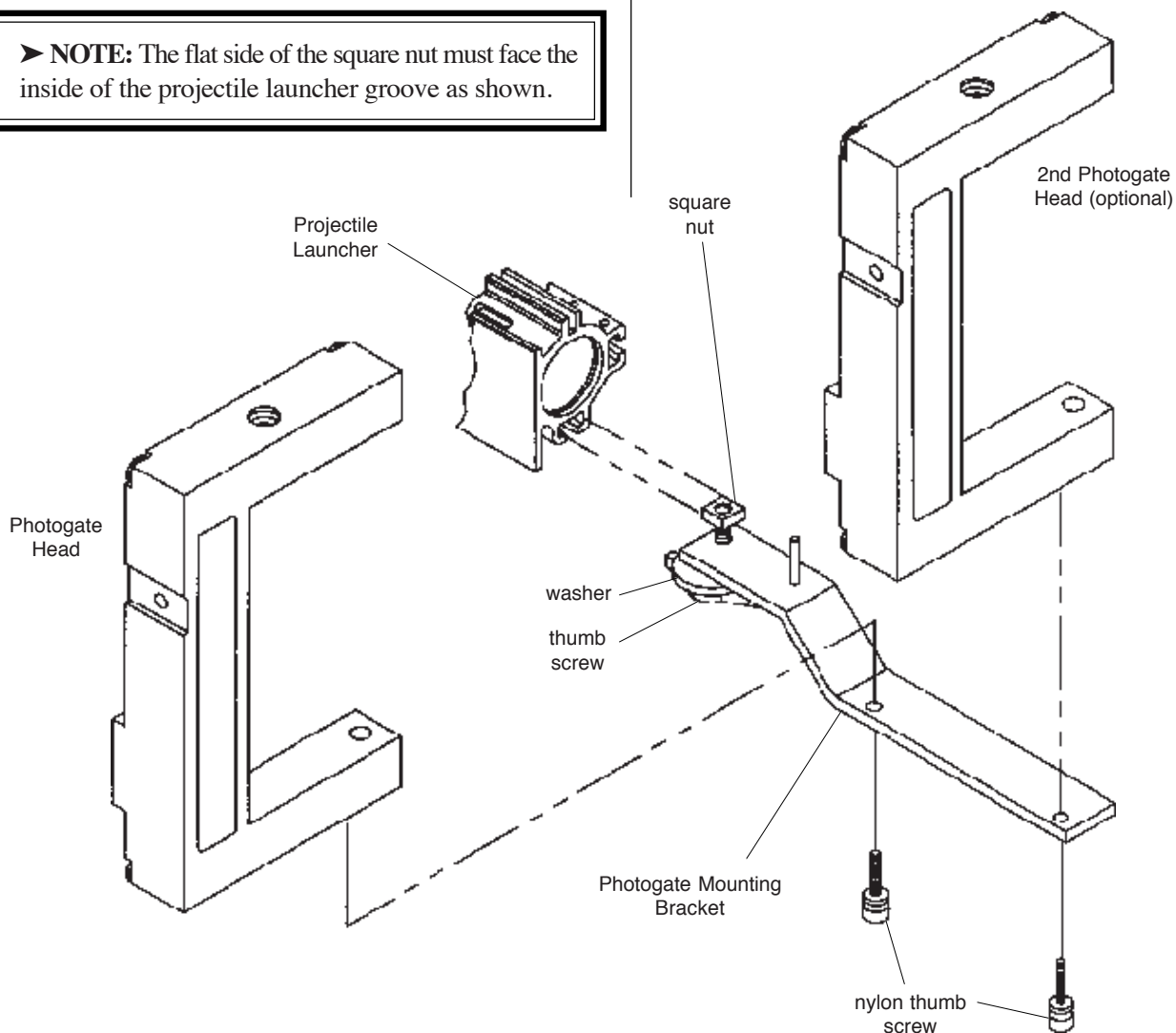

Installing the 2-Dimensional Collision Attachment

Introduction

The two dimensional collision attachment consists of 2 screws, 2 nuts, and a flat plastic bar. It is used with the Projectile Launcher to hold a second ball in front of the muzzle so the launched ball will collide with the second ball, creating a 2-dimensional collision.

Assembly

To assemble the collision attachment, insert the screws through the holes and secure with the nuts as shown below.

To mount the collision attachment to the Launcher the square nut slides into the T-shaped channel on the bottom of the barrel. (See Experiment Figure 6.2)

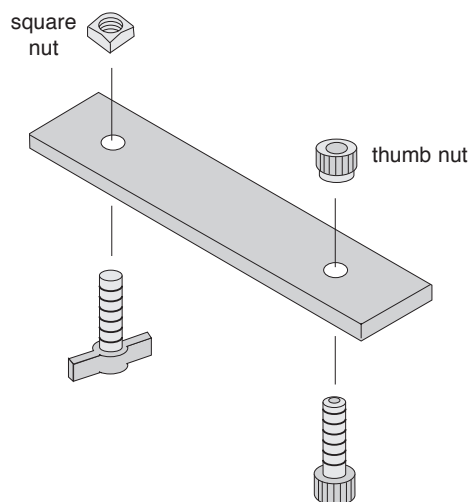

Expectations for the Projectile Launcher

The following are helpful hints and approximate values you may find useful:

- ① The muzzle speed will vary slightly with angle. The difference between muzzle speed when shot horizontally versus vertically can be anywhere from zero to 8%, depending on the range setting and the particular launcher.
- ② The scatter pattern may not be smaller on the short range than on the long range as might be expected because the ball doesn't seat as well in the piston at low accelerations.
- ③ Although the muzzle end of the Projectile Launcher doesn't change height with angle, it is about 30 cm (12 inches) above table level, so if it is desired to use the simple range formula, it is necessary to launch to a table that is at the same height as the muzzle.
- ④ The scatter pattern is minimized when the Projectile Launcher base is securely clamped to a sturdy table. Any wobble in the table will show up in the data.
- ⑤ The angle of inclination can be determined to within one-half of a degree.

Expectations for the Ballistic Pendulum

- ① Angles reached should be repeatable to within half a degree.
- ② Overall error in measurement of ball velocity should not exceed 2.5% (exact method) or 10% (approximate method).

► **NOTE:** Adjustable leveling feet are not necessary for good results. Small deviations from the horizontal will not cause significant error.

Experiment 1: Projectile Motion

EQUIPMENT NEEDED:

- Projectile Launcher and plastic ball
- Plumb bob
- meter stick
- carbon paper
- white paper

Purpose

The purpose of this experiment is to predict and verify the range of a ball launched at an angle. The initial velocity of the ball is determined by launching it horizontally and measuring the range and the height of the launcher.

Theory

To predict where a ball will land on the floor when it is launched off a table at some angle above the horizontal, it is necessary to first determine the initial speed (muzzle velocity) of the ball. This can be determined by launching the ball horizontally off the table and measuring the vertical and horizontal distances through which the ball travels. Then the initial velocity can be used to calculate where the ball will land when the ball is launched at an angle.

► **NOTE:** For best results, see the notes on "Repeatable Results" in the Introduction.

HORIZONTAL INITIAL VELOCITY:

For a ball launched horizontally off a table with an initial speed, v_0 , the horizontal distance travelled by the ball is given by $x = v_0 t$, where t is the time the ball is in the air. Air friction is assumed to be negligible.

The vertical distance the ball drops in time t is given $y = \frac{1}{2} g t^2$

The initial velocity of the ball can be determined by measuring x and y . The time of flight of the ball can be found using:

$$t = \sqrt{\frac{2y}{g}}$$

and then the initial velocity can be found using $v_0 = \frac{x}{t}$.

INITIAL VELOCITY AT AN ANGLE:

To predict the range, x , of a ball launched with an initial velocity at an angle, θ , above the horizontal, first predict the time of flight using the equation for the vertical motion:

$$y = y_0 + (v_0 \sin\theta) t - \frac{1}{2} g t^2$$

where y_0 is the initial height of the ball and y is the position of the ball when it hits the floor. Then use $x = (v_0 \cos\theta) t$ to find the range.

Setup

- ① Clamp the Projectile Launcher to a sturdy table near one end of the table.
- ② Adjust the angle of the launcher to zero degrees so the ball will be launched horizontally.

Procedure

Part A: Determining the Initial Velocity of the Ball

- ① Put the plastic ball into the Projectile Launcher and cock it to the long range position. Launch one ball to locate where the ball hits the floor. At this position, tape a piece of white paper to the floor. Place a piece of carbon paper (carbon-side down) on top of this paper and tape it down. When the ball hits the floor, it will leave a mark on the white paper.
- ② Fire about ten shots.
- ③ Measure the vertical distance from the bottom of the ball as it leaves the barrel (this position is marked on the side of the barrel) to the floor. Record this distance in Table 1.1.
- ④ Use a plumb bob to find the point on the floor that is directly beneath the release point on the barrel. Measure the horizontal distance along the floor from the release point to the leading edge of the paper. Record in Table 1.1.
- ⑤ Measure from the leading edge of the paper to each of the ten dots and record these distances in Table 1.1.
- ⑥ Find the average of the ten distances and record in Table 1.1.
- ⑦ Using the vertical distance and the average horizontal distance, calculate the time of flight and the initial velocity of the ball. Record in Table 1.1.

Part B: Predicting the Range of the Ball Launched at an Angle

- ① Adjust the angle of the Projectile Launcher to an angle between 30 and 60 degrees and record this angle in Table 1.2.
- ② Using the initial velocity and vertical distance found in the first part of this experiment, assume the ball is launched at the new angle you have just selected and calculate the new time of flight and the new horizontal distance. Record in Table 1.2.
- ③ Draw a line across the middle of a white piece of paper and tape the paper on the floor so the line is at the predicted horizontal distance from the Projectile Launcher. Cover the paper with carbon paper.
- ④ Launch the ball ten times.
- ⑤ Measure the ten distances and take the average. Record in Table 1.2.

Analysis

- ① Calculate the percent difference between the predicted value and the resulting average distance when launched at an angle.
- ② Estimate the precision of the predicted range. How many of the final 10 shots landed within this range?

Table 1.1 Determining the Initial Velocity

Vertical distance = _____ Horizontal distance to paper edge = _____

Calculated time of flight = _____ Initial velocity = _____

Trial Number	Distance
1	
2	
3	
4	
5	
6	
7	
8	
9	
10	
Average	
Total Distance	

Table 1.2 Confirming the Predicted Range

Angle above horizontal = _____ Horizontal distance to paper edge = _____

Calculated time of flight = _____ Predicted Range = _____

Trial Number	Distance
1	
2	
3	
4	
5	
6	
7	
8	
9	
10	
Average	
Total Distance	

Experiment 2: Projectile Motion Using Photogates

EQUIPMENT NEEDED

- | | |
|--|---|
| <ul style="list-style-type: none"> - Projectile Launcher and plastic ball - (2) Photogate Heads - plumb bob - carbon paper | <ul style="list-style-type: none"> -Photogate Mounting Bracket - computer - meter stick - white paper |
|--|---|

Purpose

The purpose of this experiment is to predict and verify the range of a ball launched at an angle. Photogates are used to determine the initial velocity of the ball.

Theory

To predict where a ball will land on the floor when it is launched off a table at some angle above the horizontal, it is necessary to first determine the initial speed (muzzle velocity) of the ball. This can be determined by launching the ball and measuring the speed using photogates. To predict the range, x , of the ball when it is launched with an initial velocity at an angle θ , above the horizontal, first predict the time of flight using the equation for the vertical motion:

$$y = y_0 + (v_0 \sin\theta) t - \frac{1}{2} g t^2$$

where y_0 is the initial height of the ball and y is the position of the ball when it hits the floor. Then use $x = (v_0 \cos\theta) t$ to find the range.

► **NOTE:** For best results, see the notes on "Repeatable Results" in the Introduction.

Setup

- ① Clamp the Projectile Launcher to a sturdy table near one end of the table.
- ② Adjust the angle of the Projectile Launcher to an angle between 30 and 60 degrees.
- ③ Attach the photogate bracket to the launcher and attach two photogates to the bracket. Plug the photogates into a computer or other timer.

Procedure

PART A: Determining the Initial Velocity of the Ball

- ① Put the plastic ball into the Projectile Launcher and cock it to the long range position.
- ② Run the timing program and set it to measure the time between the ball blocking the two photogates.
- ③ Launch the ball three times and take the average of these times. Record in Table 2.1.
- ④ Using that the distance between the photogates is 10 cm, calculate the initial speed and record it in Table 2.1.

Table 2.1 Initial Speed

Trial Number	Time
1	
2	
3	
Average Time	
Initial Speed	

PART B: Predicting the Range of the Ball Launched at an Angle

- ① Keep the angle of the Projectile Launcher at the chosen angle.
- ② Measure the vertical distance from the bottom of the ball as it leaves the barrel (this position is marked on the side of the barrel) to the floor. Record this distance in Table 2.2.
- ③ Using the initial velocity and vertical distance found, assume the ball is launched at the angle you have selected and calculate the time of flight and the horizontal distance. Record in Table 2.2.
- ④ Draw a line across the middle of a white piece of paper and tape the paper on the floor so the line is at the predicted horizontal distance from the Projectile Launcher. Cover the paper with carbon paper.
- ⑤ Launch the ball ten times.
- ⑥ Measure the ten distances and take the average. Record in Table 2.2.

Analysis

- ① Calculate the percent difference between the predicted value and the resulting average distance when launched at an angle.
- ② Estimate the precision of the predicted range. How many of the final 10 shots landed within this range?

Table 2.2 Confirming the Predicted Range

Angle above horizontal = _____

Horizontal distance to paper edge = _____

Calculated time of flight= _____

Predicted Range = _____

Trial Number	Distance
1	
2	
3	
4	
5	
6	
7	
8	
9	
10	
Average	
Total Distance	

Experiment 3: Projectile Range Versus Angle

EQUIPMENT NEEDED

- | | |
|--|----------------|
| - Projectile Launcher and plastic ball | - plumb bob |
| - measuring tape or meter stick | - carbon paper |
| - box to make elevation same as muzzle | - white paper |
| - graph paper | |

Purpose

The purpose of this experiment is to find how the range of the ball depends on the angle at which it is launched. The angle that gives the greatest range is determined for two cases: for launching on level ground and for launching off a table.

Theory

The range is the horizontal distance, x , between the muzzle of the launcher and the place where the ball hits, given by $x = (v_0 \cos \theta) t$, where v_0 is the initial speed of the ball as it leaves the muzzle, θ is the angle of inclination above horizontal, and t is the time of flight. See Figure 3.1.

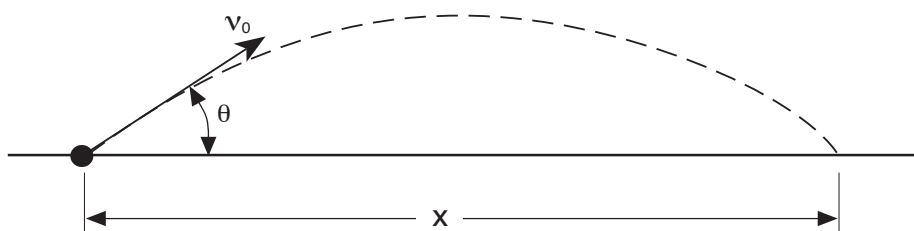

Figure 3.1 Launching on a level surface

For the case in which the ball hits on a place that is at the same level as the level of the muzzle of the launcher, the time of flight of the ball will be twice the time it takes the ball to reach the peak of its trajectory. At the peak, the vertical velocity is zero so

$$v_y = 0 = v_0 \sin \theta - g t_{peak}$$

Therefore, solving for the time gives that the total time of flight is

$$t = 2t_{peak} = 2 \frac{v_0 \sin \theta}{g}$$

For the case in which the ball is launched at an angle off a table onto the floor (See Figure 3.2) the time of flight is found using the equation for the vertical motion:

$$y = y_0 + (v_0 \sin \theta) t - \frac{1}{2} g t^2$$

where y_0 is the initial height of the ball and y is the position of the ball when it hits the floor.

► **NOTE:** For best results, see the notes on "Repeatable Results" in the Introduction.

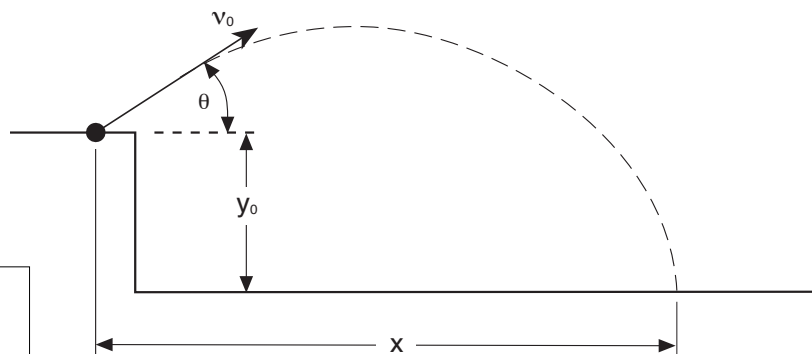

Figure 3.2 Launching off the table

Setup

- ① Clamp the Projectile Launcher to a sturdy table near one end of the table with the launcher aimed so the ball will land on the table.
- ② Adjust the angle of the Projectile Launcher to ten degrees.
- ③ Put the plastic ball into the Projectile Launcher and cock it to the medium or long range position.

► **NOTE:** In general, this experiment will not work as well on the short range setting because the muzzle velocity is more variable with change in angle.

Launch a ball to locate where the ball hits. Place a box at that location so the ball will hit at the same level as the muzzle of the launcher. See Figure 3.3.

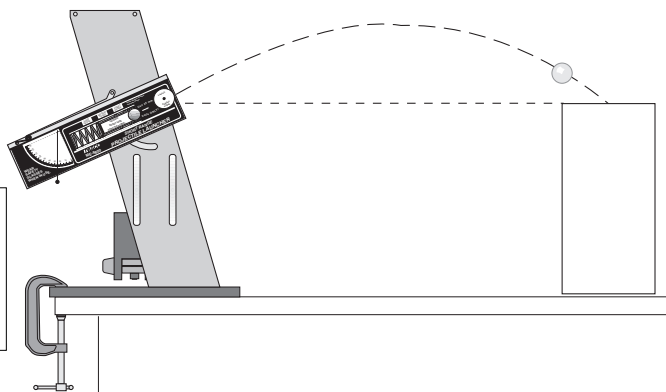

Figure 3.3 Setup to launch on level surface

Procedure

LAUNCHING ON A LEVEL SURFACE

- ① Fire one shot to locate where the ball hits the box. At this position, tape a piece of white paper to the box. Place a piece of carbon paper (carbon-side down) on top of this paper and tape it down. When the ball hits the box, it will leave a mark on the white paper.
- ② Fire about five shots.
- ③ Use a measuring tape to measure the horizontal distance from the muzzle to the leading edge of the paper. If a measuring tape is not available, use a plumb bob to find the point on the table that is directly beneath the release point on the barrel. Measure the horizontal distance along the table from the release point to the leading edge of the paper. Record in Table 3.1.
- ④ Measure from the leading edge of the paper to each of the five dots and record these distances in Table 3.1.
- ⑤ Increase the angle by 10 degrees and repeat all the steps.
- ⑥ Repeat for angles up to and including 80 degrees.

Table 3.1 Launching on a Level Surface

Horizontal. Distance	Angle	10	20	30	40	50	60	70	80
	1								
	2								
	3								
	4								
	5								
	Average								
	Paper Dist.								
	Total Dist.								

LAUNCHING OFF THE TABLE

Aim the Projectile Launcher so the ball will hit the floor. Repeat the procedure and record the data in Table 3.2.

Table 3.2 Launching off the Table onto the Floor

Angle	10	20	30	40	50	60	70	80
1								
2								
3								
4								
5								
Average								
Paper Dist.								
Total Dist.								

Horizontal. Distance

Analysis

- ① Find the average of the five distances in each case and record in Tables 3.1 and 3.2.
- ② Add the average distance to the distance to the leading edge of the paper to find the total distance (range) in each case. Record in Tables 3.1 and 3.2.
- ③ For each data table, plot the range vs. angle and draw a smooth curve through the points.

Questions

- ① From the graph, what angle gives the maximum range for each case?
- ② Is the angle for the maximum range greater or less for launching off the Table?
- ③ Is the maximum range further when the ball is launched off the table or on the level surface?

Experiment 4: Projectile Path

EQUIPMENT NEEDED

- Projectile Launcher and plastic ball
- carbon paper
- movable vertical target board (Must reach from floor to muzzle)
- graph paper
- measuring tape or meter stick
- white paper

Purpose

The purpose of this experiment is to find how the vertical distance the ball drops is related to the horizontal distance the ball travels when the ball is launched horizontally from a table.

Theory

The range is the horizontal distance, x , between the muzzle of the launcher and the place where the ball hits, given by $x = v_0 t$, where v_0 is the initial speed of the ball as it leaves the muzzle and t is the time of flight.

If the ball is launched horizontally, the time of flight of the ball will be

$$t = \frac{x}{v_0}$$

The vertical distance, y , that the ball falls in time t is given by

$$y = \frac{1}{2} g t^2$$

where g is the acceleration due to gravity.

Substituting for t into the equation for y gives

$$y = \left(\frac{g}{2v_0^2} \right) x^2$$

A plot of y versus x^2 will give a straight line with a slope equal to $\frac{g}{2v_0^2}$.

► **NOTE:** For best results, see the notes on "Repeatable Results" in the Introduction.

Setup

- ① Clamp the Projectile Launcher to a sturdy table near one end of the table with the launcher aimed away from the table.
- ② Adjust the angle of the Projectile Launcher to zero degrees so the ball will be launched horizontally.
- ③ Fire a test shot on medium range to determine the initial position of the vertical target. Place the target so the ball hits it near the bottom. See Figure 4.1.
- ④ Cover the target board with white paper. Tape carbon paper over the white paper.

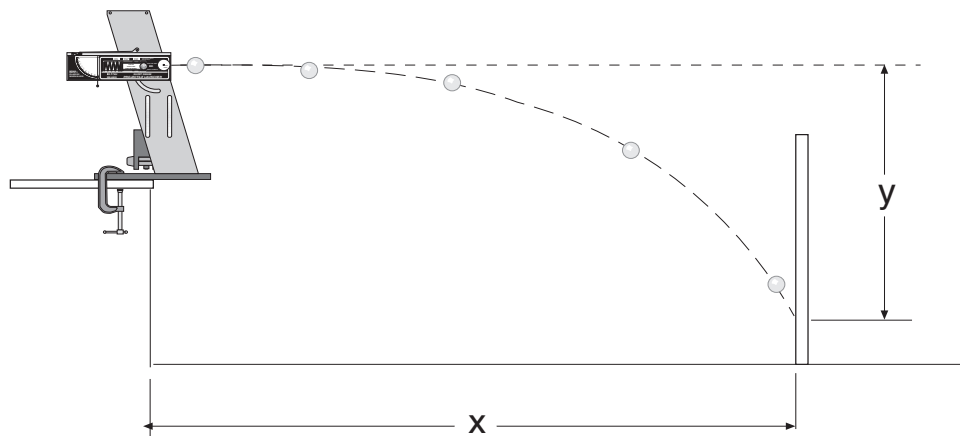

Figure 4.1 Setup

Procedure

- ① Measure the vertical height from the floor to the muzzle and record in Table 4.1. Mark this height on the target.
- ② Measure the horizontal distance from the muzzle of the Projectile Launcher to the target and record in Table 4.1.
- ③ Launch the ball.
- ④ Move the target about 10 to 20 cm closer to the launcher.
- ⑤ Repeat Steps 2 through 4 until the height of the ball when it strikes the target is about 10 to 20 cm below the height of the muzzle.

Table 4.1 Data

Height of Muzzle = _____

Horizontal (x)	Height (y)	x^2

Analysis

- ① On the target, measure the vertical distances from the muzzle level mark down to the ball marks and record in Table 4.1.
- ② Calculate x^2 for all the data points and record in Table 4.1.
- ③ Plot y vs. x^2 and draw the best-fit straight line.
- ④ Calculate the slope of the graph and record in Table 4.2.
- ⑤ From the slope of the graph, calculate the initial speed of the ball as it leaves the muzzle and record in Table 4.2.
- ⑥ Using any data point for x and y , calculate the time using y and then calculate the initial speed using this time and x . Record the results in Table 4.2.
- ⑦ Calculate the percent difference between the initial speeds found using these two methods. Record in Table 4.2.

Table 4.2 Initial Speed

Slope of graph	
Initial speed from slope	
Time of flight	
Initial speed from x, y	
Percent Difference	

Questions

- ① Was the line straight? What does this tell you about the relationship between y and x ?
- ② If you plotted y vs. x , how would the graph differ from the y vs. x^2 graph?
- ③ What shape is the path of a projectile?

Experiment 5: Conservation of Energy

EQUIPMENT NEEDED

- Projectile Launcher and plastic ball
- measuring tape or meter stick
- carbon paper
- (optional) 2 Photogate Heads and Photogate Mounting Bracket
- plumb bob
- white paper

Purpose

The purpose of this experiment is to show that the kinetic energy of a ball launched straight up is transformed into potential energy.

Theory

The total mechanical energy of a ball is the sum of its potential energy (PE) and its kinetic energy (KE). In the absence of friction, total energy is conserved. When a ball is launched straight up, the initial PE is defined to be zero and the $KE = \frac{1}{2}mv_0^2$, where m is the mass of the ball and v_0 is the muzzle speed of the ball. See Figure 5.1. When the ball reaches its maximum height, h , the final KE is zero and the $PE = mgh$, where g is the acceleration due to gravity. Conservation of energy gives that the initial KE is equal to the final PE.

To calculate the kinetic energy, the initial velocity must be determined. To calculate the initial velocity, v_0 , for a ball launched horizontally off a table, the horizontal distance travelled by the ball is given by $x = v_0t$, where t is the time the ball is in the air. Air friction is assumed to be negligible. See Figure 5.2.

The vertical distance the ball drops in time t is given by $y = \frac{1}{2}gt^2$.

The initial velocity of the ball can be determined by measuring x and y . The time of flight of the ball can be found using

$$t = \sqrt{\frac{2y}{g}}$$

and then the initial velocity can be found using $v_0 = \frac{x}{t}$.

► **NOTE:** For best results, see the notes on "Repeatable Results" in the Introduction.

Setup

- ① Clamp the Projectile Launcher to a sturdy table near one end of the table with the launcher aimed away from the table. See Figure 5.1.
- ② Point the launcher straight up and fire a test shot on medium range to make sure the ball doesn't hit the ceiling. If it does, use the short range throughout this experiment or put the launcher closer to the floor.

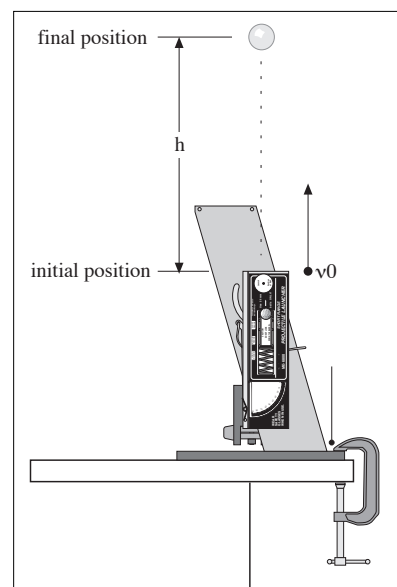

Figure 5.1 Conservation of Energy

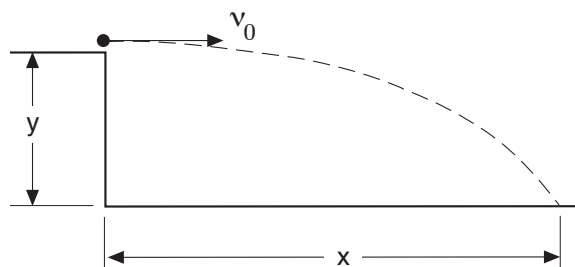

Figure 5.2 Finding the Initial Velocity

- ③ Adjust the angle of the Projectile Launcher to zero degrees so the ball will be launched horizontally.

Procedure

PART I: Determining the Initial Velocity of the Ball (without photogates)

- ① Put the plastic ball into the Projectile Launcher and cock it to the medium range position. Fire one shot to locate where the ball hits the floor. At this position, tape a piece of white paper to the floor. Place a piece of carbon paper (carbon-side down) on top of this paper and tape it down. When the ball hits the floor, it will leave a mark on the white paper.
- ② Fire about ten shots.
- ③ Measure the vertical distance from the bottom of the ball as it leaves the barrel (this position is marked on the side of the barrel) to the floor. Record this distance in Table 5.1.
- ④ Use a plumb bob to find the point on the floor that is directly beneath the release point on the barrel. Measure the horizontal distance along the floor from the release point to the leading edge of the paper. Record in Table 5.1.
- ⑤ Measure from the leading edge of the paper to each of the ten dots and record these distances in Table 5.1.
- ⑥ Find the average of the ten distances and record in Table 5.1.
- ⑦ Using the vertical distance and the average horizontal distance, calculate the time of flight and the initial velocity of the ball. Record in Table 5.1.

Alternate Method for Determining the Initial Velocity of the Ball (using photogates)

- ① Attach the photogate bracket to the launcher and attach two photogates to the bracket. Plug the photogates into a computer or other timer.
- ② Adjust the angle of the Projectile Launcher to 90 degrees (straight up).
- ③ Put the plastic ball into the Projectile Launcher and cock it to the long range position.
- ④ Run the timing program and set it to measure the time between the ball blocking the two photogates.
- ⑤ Launch the ball three times and take the average of these times. Record in Table 5.2.
- ⑥ Assuming that the distance between the photogates is 10 cm, calculate the initial speed and record it in Table 5.2.

Table 5.1 Determining the Initial Velocity without Photogates

Vertical distance = _____ Calculated time of flight= _____

Horizontal distance to paper edge = _____ Initial velocity = _____

Trial Number	Distance
1	
2	
3	
4	
5	
6	
7	
8	
9	
10	
Average	
Total Distance	

Table 5.2 Initial Speed Using Photogates

TRIAL NUMBER	TIME
1	
2	
3	
AVERAGE TIME	
INITIAL SPEED	

Measuring the Height

- ① Adjust the angle of the launcher to 90 degrees (straight up).
- ② Launch the ball on the medium range setting several times and measure the maximum height attained by the ball. Record in Table 5.3.
- ③ Determine the mass of the ball and record in Table 5.3.

Analysis

- ① Calculate the initial kinetic energy and record in Table 5.3.
- ② Calculate the final potential energy and record in Table 5.3.
- ③ Calculate the percent difference between the initial and final energies and record in Table 5.3.

Table 5.3 Results

Maximum Height of Ball	
Mass of Ball	
Initial Kinetic Energy	
Final Potential Energy	
Percent Difference	

Questions

- ① How does friction affect the result for the kinetic energy?
- ② How does friction affect the result for the potential energy?

Experiment 6: Conservation of Momentum In Two Dimensions

EQUIPMENT NEEDED

- Projectile Launcher and 2 plastic balls
- meter stick
- butcher paper
- stand to hold ball
- plumb bob
- protractor
- tape to make collision inelastic
- carbon paper

Purpose

The purpose of this experiment is to show that the momentum is conserved in two dimensions for elastic and inelastic collisions.

Theory

A ball is launched toward another ball which is initially at rest, resulting in a collision after which the two balls go off in different directions. Both balls are falling under the influence of the force of gravity so momentum is not conserved in the vertical direction. However, there is no net force on the balls in the horizontal plane so momentum is conserved in horizontal plane.

Before the collision, since all the momentum is in the direction of the velocity of Ball #1 it is convenient to define the x-axis along this direction. Then the momentum before the collision is

$$\vec{P}_{before} = m_1 v_0 \hat{x}$$

and the momentum after the collision is

$$\vec{P}_{after} = (m_1 v_{1x} + m_2 v_{2x}) \hat{x} + (m_1 v_{1y} - m_2 v_{2y}) \hat{y}$$

where $v_{1x} = v_1 \cos\theta_1$, $v_{1y} = v_1 \sin\theta_1$, $v_{2x} = v_2 \cos\theta_2$, and $v_{2y} = v_2 \sin\theta_2$.

Since there is no net momentum in the y-direction before the collision, conservation of momentum requires that there is no momentum in the y-direction after the collision.

Therefore,

$$m_1 v_{1y} = m_2 v_{2y}$$

Equating the momentum in the x-direction before the collision to the momentum in the x-direction after the collision gives

$$m_1 v_0 = m_1 v_{1x} + m_2 v_{2x}$$

In an elastic collision, energy is conserved as well as momentum.

$$\frac{1}{2} m_1 v_0^2 = \frac{1}{2} m_1 v_1^2 + \frac{1}{2} m_2 v_2^2$$

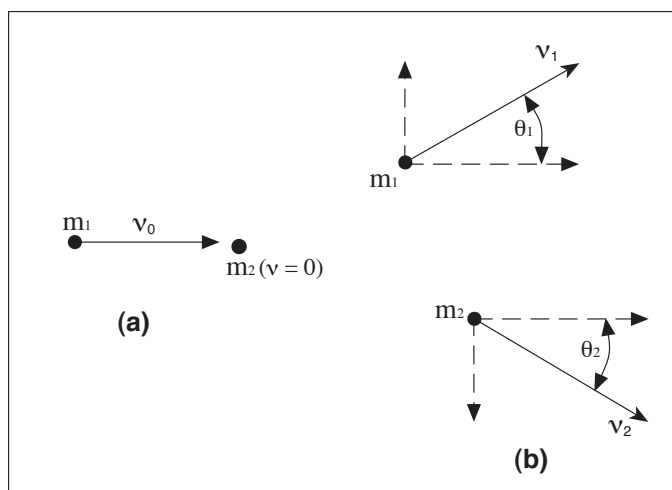

Figure 6.1: (a) Before Collision
(b) After Collision

Also, when energy is conserved, the paths of two balls (of equal mass) after the collision will be at right angles to each other.

► **NOTE:** For best results, see the notes on "Repeatable Results" in the Introduction.

Setup

- ① Clamp the Projectile Launcher to a sturdy table near one end of the table with the launcher aimed inward toward the table.
- ② Adjust the angle of the Projectile Launcher to zero degrees so the ball will be launched horizontally onto the table. Fire a test shot on the short range setting to make sure the ball lands on the table.
- ③ Cover the table with butcher paper. The paper must extend to the base of the launcher.
- ④ Mount collision attachment on the launcher. See Figure 6.2. Slide the attachment back along the launcher until the tee is about 3 cm in front of the muzzle.
- ⑤ Rotate the attachment to position the ball from side to side. The tee must be located so that neither ball rebounds into the launcher and so both balls land on the table. Tighten the screw to secure the collision attachment to the launcher.
- ⑥ Adjust the height of the tee so that the two balls are at the same level. This is necessary to ensure that the time of flight is the same for each ball. Fire a test shot and listen to determine if the two balls hit the table at the same time.
- ⑦ Place a piece of carbon paper at each of the three sites where the balls will land.

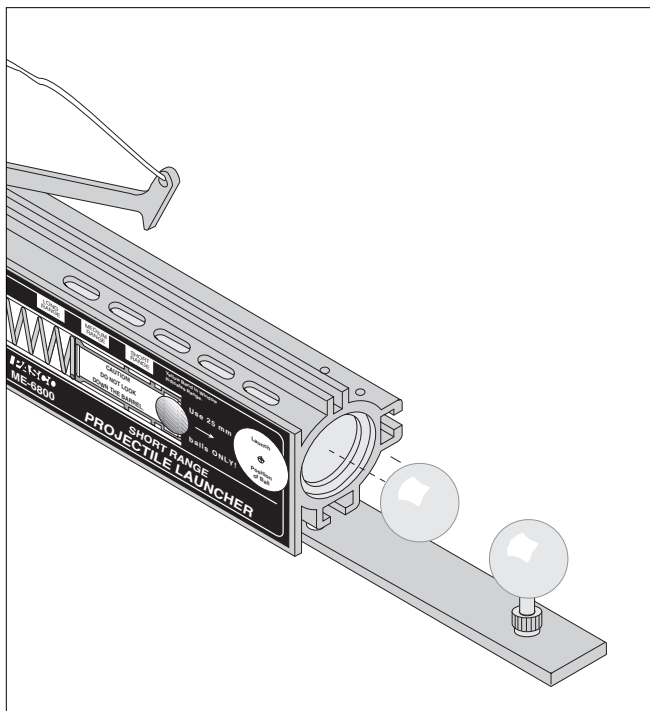

Figure 6.2: Photogate Bracket and Tee

Procedure

- ① Using one ball, launch the ball straight five times.
- ② **Elastic collision:** Using two balls, load one ball and put the other ball on the tee. Launch the ball five times.
- ③ **Inelastic collision:** Using two balls, load one ball and stick a very small loop of tape onto the tee ball. Orient the tape side of the tee ball so it will be struck by the launched ball, causing an inelastic collision. Launch the ball once and if the balls miss the carbon paper, relocate the carbon paper and launch once more. Since the tape does not produce the same inelastic collision each time, it is only useful to record this collision once.
- ④ Use a plumb bob to locate on the paper the spot below the point of contact of the two balls. Mark this spot.

Analysis

- ① Draw lines from the point-of-contact spot to the centers of the groups of dots. There will be five lines.
- ② Measure the lengths of all five lines and record on the paper. Since the time of flight is the same for all paths, these lengths are proportional to the corresponding horizontal velocities. Since the masses are also the same, these lengths are also proportional to the corresponding momentum of each ball.
- ③ Measure the angles from the center line to each of the outer four lines and record on the paper.

PERFORM THE FOLLOWING THREE STEPS FOR THE ELASTIC COLLISION AND THEN REPEAT THESE THREE STEPS FOR THE INELASTIC COLLISION:

- ④ For the x-direction, check that the momentum before equals the momentum after the collision. To do this, use the lengths for the momentums and calculate the x-components using the angles. Record the results in Tables 6.1 and 6.2.

Table 6.1 Results for the Elastic Collision

Initial x-momentum		Final x-momentum		% difference	
y-momentum ball 1		y-momentum ball 2		% difference	
Initial KE		Final KE		% difference	

Table 6.2 Results for the Inelastic Collision

Initial x-momentum		Final x-momentum		% difference	
y-momentum ball 1		y-momentum ball 2		% difference	
Initial KE		Final KE		% difference	

- ⑤ For the y-direction, check that the momenta for the two balls are equal and opposite, thus canceling each other. To do this, calculate the y-components using the angles. Record the results in the Tables.
- ⑥ Calculate the total kinetic energy before and the total kinetic energy after the collision. Calculate the percent difference. Record the results in the Tables.

Questions

- ① Was momentum conserved in the x-direction for each type of collision?
- ② Was momentum conserved in the y-direction for each type of collision?
- ③ Was energy conserved for the elastic collision?
- ④ Was energy conserved for the inelastic collision?
- ⑤ For the elastic collision, was the angle between the paths of the balls after the collision equal to 90 degrees as expected?
- ⑥ For the inelastic collision, what was the angle between the paths of the balls after the collision? Why is it less than 90°?

Experiment 7: Varying Angle To Maximize Height on a Wall

EQUIPMENT NEEDED

- Projectile Launcher and plastic ball
- measuring tape or meter stick
- white paper
- plumb bob
- carbon paper
- board to protect wall

Purpose

The purpose of this experiment is to find the launch angle which will maximize the height on a vertical wall for a ball launched at a fixed horizontal distance from the wall.

Theory

When the ball is launched at an angle at a fixed distance, x , from a vertical wall, it hits the wall at a height y given by:

$$y = y_0 + (v_0 \sin \theta) t - \frac{1}{2} g t^2$$

where y_0 is the initial height of the ball, v_0 is the initial speed of the ball as it leaves the muzzle, θ is the angle of inclination above horizontal, g is the acceleration due to gravity, and t is the time of flight. The range is the horizontal distance, x , between the muzzle of the launcher and the place where the ball hits,

given by $x = (v_0 \cos \theta) t$. Solving for the time of flight from the equation for x gives

$$t = \frac{x}{v_0 \cos \theta}$$

Substituting for t in the equation for y gives

$$y = y_0 + x \tan \theta - \frac{g x^2}{2 v_0^2 \cos^2 \theta}$$

To find the angle that gives the maximum height, y , set $dy/d\theta$ equal to zero and solve for the angle.

$$\frac{dy}{d\theta} = x \sec^2 \theta - \frac{g x^2 \tan \theta \sec^2 \theta}{v_0^2} = 0$$

Solving for the angle gives

$$\tan \theta_{\max} = \frac{v_0^2}{g x}$$

Since the second derivative is negative for θ_{\max} , the angle is a maximum.

To find the initial velocity of the ball, the fixed distance x and the maximum height y_{\max} can be used. Solve the y -equation for v_0 and plug in the values for y_{\max} , θ_{\max} , and x .

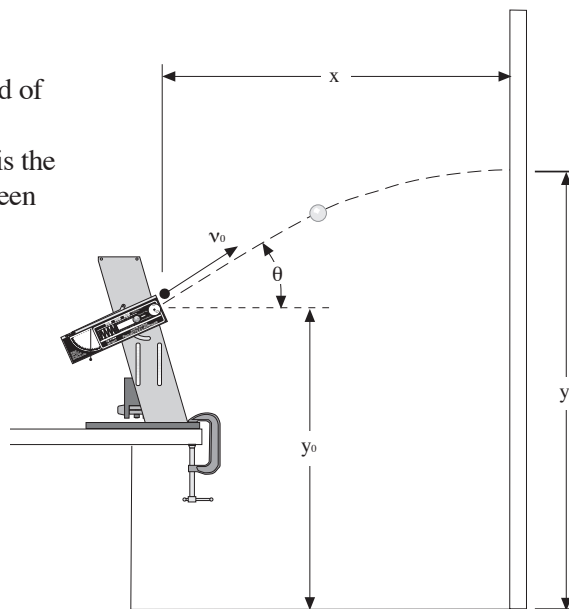

Figure 7.1 Maximizing Height

► **NOTE:** For best results, see the notes on "Repeatable Results" in the Introduction.

Setup

- ① Clamp the Projectile Launcher to a sturdy table near one end of the table with the launcher facing the wall at a distance of about 2 meters from the wall.
- ② Put a vertical board up to protect the wall.

- ③ Test fire the ball (on the long range setting) a few times to find approximately what angle gives the maximum height on the wall. (NOTE: In general, this experiment will not work as well on the short range setting because the muzzle velocity is more variable with change in angle.)
- ④ Tape a piece of white paper to the board in the region where the ball is hitting. Then cover the white paper with a piece of carbon paper.

Procedure

- ① Launch the ball at various angles and pinpoint exactly which angle gives the maximum height by checking the marks on the paper.
- ② Measure the angle that produces the maximum height and record in Table 7.1.
- ③ Measure the maximum height and record in Table 7.1.
- ④ Measure the horizontal distance from the muzzle to the vertical board and record in Table 7.1.
- ⑤ Measure the initial height of the ball where it leaves the muzzle and record in Table 7.1.

Table 7.1 Data and Results

Measured Angle for Max	
Maximum Height	
Horizontal Distance	
Initial Height	
Calculated Initial Velocity	
Calculated Angle for Max	
% Difference Between Angles	

Analysis

- ① Calculate the initial velocity by solving the y-equation for v_0 and plugging in the values from Table 7.1.
- ② Calculate the angle for maximum height using the initial velocity calculated in Step 1 and the horizontal distance from the wall to the launcher.
- ③ Calculate the percent difference between the measured angle and the calculated angle.

Questions

- ① For the angle which gives the maximum height, when the ball hits the wall, has it already reached the peak of its trajectory?
- ② For what distance from the wall would the height be maximized at 45° ? What would the maximum height be in this case?

Experiment 8: Projectile Velocity—Approximate Method

EQUIPMENT NEEDED:

- | | |
|----------------------|----------------|
| - launcher | - Steel ball |
| - C-clamp (optional) | - Mass balance |
| - string | |

Purpose:

The muzzle velocity of the projectile launcher is determined by launching the ball into the pendulum and observing the angle to which the pendulum swings.

As derived earlier in this manual, the equation for the velocity of the ball is approximately

$$v_b = \frac{M}{m} \sqrt{2gR_{cm}(1 - \cos\theta)}$$

where M is the mass of the pendulum and ball combined, m is the mass of the ball, g is the acceleration of gravity, R_{cm} is the distance from the pivot to the center of mass of the pendulum, and θ is the angle reached by the pendulum.

Setup:

- ① Attach the Projectile Launcher to the ballistic pendulum mount at the level of the ball catcher. Make sure that the pendulum can hang vertically without touching the launcher.
- ② Clamp the pendulum base to the table, if a clamp is available. Make sure that the clamp does not interfere with the pendulum swing. (It is possible to get very good results without clamping to the table, as long as the base is held firmly to the table when the ball is fired.)

Procedure:

- ① Latch the pendulum at 90° so it is out of the way, then load the projectile launcher. Allow the pendulum to hang freely, and move the angle indicator to zero degrees.
- ② Fire the launcher and record the angle reached. If you want to do the experiment with a lower or higher angle, add or remove mass to the pendulum. Repeat these test measurements until you are satisfied with the mass of the pendulum.
- ③ Once you have chosen the mass to use for your experiment, remove the pendulum from the base by unscrewing and removing the pivot axle. Using the mass balance, find the mass of the pendulum and ball together. Record this value as M in table 8.1.
- ④ Measure the mass of the ball, and record this as m .
- ⑤ Tie a loop in the string, and hang the pendulum from the loop. (See figure 8.1) With the ball latched in position in the ball catcher, adjust the position of the pendulum in this loop until it balances. Measure the distance from the pivot point to this balance point, and record it as R_{cm} . You may find it easier to do this by balancing the pendulum on the edge of a ruler or similar object.

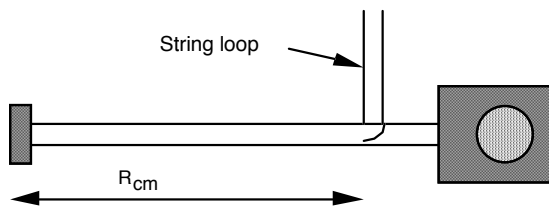

Figure 8.1

- ⑥ Replace the pendulum in the base, making sure that it is facing the right way. Be sure that the angle indicator is to the right of the pendulum rod.
- ⑦ Load the launcher, then set the angle indicator to an angle 1-2° less than that reached in step 2. This will nearly eliminate the drag on the pendulum caused by the indicator, since the pendulum will only move the indicator for the last few degrees.

Fire the launcher, and record the angle reached by the pendulum in table 8.1. Repeat this several times, setting the angle indicator to a point 1-2° below the previous angle reached by the pendulum each time.

Calculations

- ① Find the average angle reached by the pendulum. Record this value in table 8.1.
- ② Calculate the muzzle velocity of the projectile launcher.

Table 8.1

M= _____
 m= _____
 R_{cm} = _____

θ_1	
θ_2	
θ_3	
θ_4	

Questions

- ① Is there another way to measure the muzzle velocity that you could use to check your results? You may want to use another method and compare the two answers.
- ② What sources of error are there in this experiment? How much do these errors affect your result?
- ③ It would greatly simplify the calculations (see theory section) if kinetic energy were conserved in the collision between ball and pendulum. What percentage of the kinetic energy is lost in the collision between ball and pendulum? Would it be valid to assume that energy was conserved in that collision?
- ④ How does the angle reached by the pendulum change if the ball is *not* caught by the pendulum? You may test this by turning the pendulum around so the ball strikes the back of the ball catcher. Is there more energy or less energy transferred to the pendulum?

Average θ = _____

Muzzle Velocity= _____

Experiment 9: Projectile Velocity—Exact Method

EQUIPMENT NEEDED:

- | | |
|--------------------------------------|----------------------|
| - Projectile Launcher and steel ball | - C-clamp (optional) |
| - Mass Balance | - string |
| - ruler | - stopwatch |

Purpose:

The muzzle velocity of the projectile launcher is determined by launching the ball into the pendulum and observing the angle to which the pendulum swings.

The exact equation for ball velocity, as derived earlier in this manual, is

$$v = \frac{1}{mR_b} \sqrt{2IMgR_{cm}(1 - \cos\theta)}$$

where M is the mass of the pendulum and ball combined, m is the mass of the ball, g is the acceleration of gravity, R_{cm} is the distance from the pivot to the center of mass of the pendulum, R_b is the distance from the pivot to the ball, θ is the angle reached by the pendulum, and I is the moment of inertia of the pendulum with the ball in the catcher.

The value of I can be found by measuring the period of small oscillations of the pendulum and ball and using the equation

$$I = \frac{MgR_{cm}T^2}{4\pi^2}$$

where T is the period.

Setup:

- ① Attach the projectile launcher to the ballistic pendulum mount at the level of the ball catcher. Make sure that the pendulum can hang vertically without touching the launcher.
- ② Clamp the pendulum base to the table, if a clamp is available. Make sure that the clamp does not interfere with the pendulum swing. (It is possible to get very good results without clamping to the table, as long as the base is held firmly to the table when the ball is fired.)

Procedure:

- ① Latch the pendulum at 90° so it is out of the way, then load the projectile launcher. Allow the pendulum to hang freely, and move the angle indicator to zero degrees.
- ② Fire the launcher and record the angle reached. If you want to do the experiment with a lower or higher angle, add or remove mass to the pendulum. Repeat these test measurements until you are satisfied with the mass of the pendulum.
- ③ Once you have chosen the mass to use for your experiment, remove the pendulum from the base by unscrewing and removing the pivot axle. Using the mass balance, find the mass of the pendulum and ball together. Record this value as M in table 9.1.
- ④ Measure the mass of the ball, and record this as m .
- ⑤ Tie a loop in the string, and hang the pendulum from the loop. (See figure 9.1) With the ball latched in position in the ball catcher, adjust the position of the pendulum in this loop until it balances. Measure the distance from the pivot point to this balance point, and record it as R_{cm} . You may find it easier to do this by balancing the pendulum on the edge of a ruler or similar object.
- ⑥ Measure the distance between the pivot point and the center of the ball. Record this as R_b .

- ⑦ Replace the pendulum in the base, making sure that it is facing the right way. Be sure that the angle indicator is to the right of the pendulum rod.
- ⑧ Remove the launcher so that the pendulum can swing freely. With the ball in the pendulum, give it an initial displacement of 5° or less. Using the stopwatch, time how long it takes to go through at least ten oscillations. Divide this time by the number of oscillations, and record your result as T in table 9.1.
- ⑨ Calculate the value of I, and record it in table 9.1.
- ⑩ Load the launcher, then set the angle indicator to an angle 1-2° less than that reached in step 2. This will nearly eliminate the drag on the pendulum caused by the indicator, since the pendulum will only move the indicator for the last few degrees.
- ⑪ Fire the launcher, and record the angle reached by the pendulum in table 8.1. Repeat this several times, setting the angle indicator to a point 1-2° below the previous angle reached by the pendulum each time.

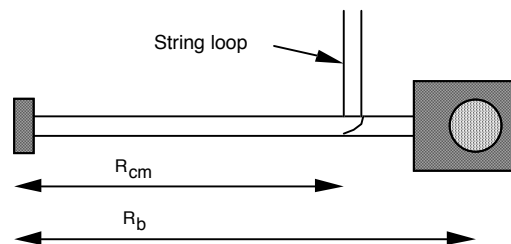

Figure 9.1

Calculations

- ① Find the average angle reached by the pendulum. Record this value in table 8.1.
- ② Calculate the muzzle velocity of the projectile launcher.

Questions

- ① Is there another way to measure the muzzle velocity that you could use to check your results? You may want to use another method and compare the two answers.
- ② What sources of error are there in this experiment? How much do these errors affect your result?
- ③ It would greatly simplify the calculations (see theory section) if kinetic energy were conserved in the collision between ball and pendulum. What percentage of the kinetic energy is lost in the collision between ball and pendulum? Would it be valid to assume that energy was conserved in that collision?
- ④ Does increasing the pendulum mass increase or decrease the efficiency of the energy transfer in the collision? Try it.
- ⑤ Experiment 8 uses an approximate equation for velocity:

$$v_b = \frac{M}{m} \sqrt{2gR_{cm}(1 - \cos\theta)}$$

What is the value of velocity when you use this equation? Is there a significant difference between these two calculated values? What factors would increase the difference between these two results? How would you build a ballistic pendulum so that the approximate equation gave better results?

Table 9.1

M= _____
 m= _____
 R_{cm} = _____
 R_b = _____
 T= _____
 I= _____

θ_1	
θ_2	
θ_3	
θ_4	

Average θ = _____

Muzzle Velocity= _____

Experiment 10 (Demo): Do 30° and 60° Give the Same Range?

EQUIPMENT NEEDED

- Projectile Launcher and steel ball
- box to make elevation same as muzzle

Purpose

The purpose of this demonstration is to show that the range of a ball launched at 30° is the same as one launched at 60° if the ball is launched on a level surface.

Theory

The range is the horizontal distance, x , between the muzzle of the launcher and the place where the ball hits, given by $x = (v_0 \cos \theta) t$ where v_0 is the initial speed of the ball as it leaves the muzzle, θ is the angle of inclination above horizontal, and t is the time of flight.

If the ball hits on a place that is at the same level as the level of the muzzle of the launcher, the time of flight of the ball will be twice the time it takes the ball to reach the peak of its trajectory:

$$t = 2t_{peak} = 2 \frac{v_0 \sin \theta}{g}$$

where g is the acceleration due to gravity.

Substituting for t into the equation for x gives

$$x = \frac{2v_0^2 \sin \theta \cos \theta}{g}$$

and using a trigonometry identity gives

$$x = \frac{2v_0^2 \sin 2\theta}{g}$$

The ranges for the angles 30° and 60° are the same since

$$\sin(60^\circ) = \sin(120^\circ).$$

► **NOTE:** For best results, see the notes on "Repeatable Results" in the Introduction.

Setup

- ① Clamp the Projectile Launcher to a sturdy table near one end of the table with the launcher aimed so the ball will land on the table.
- ② Adjust the angle of the Projectile Launcher to 30 degrees.
- ③ Put the steel ball into the Projectile Launcher and cock it to the medium or long range position.

► **NOTE:** In general, this experiment will not work as well on the short range setting because the muzzle velocity is more variable with change in angle.)

- ④ Launch a ball to locate where the ball hits. Place an inverted box at that location so the ball will hit at the same level as the muzzle of the launcher. See Figure 10.1.

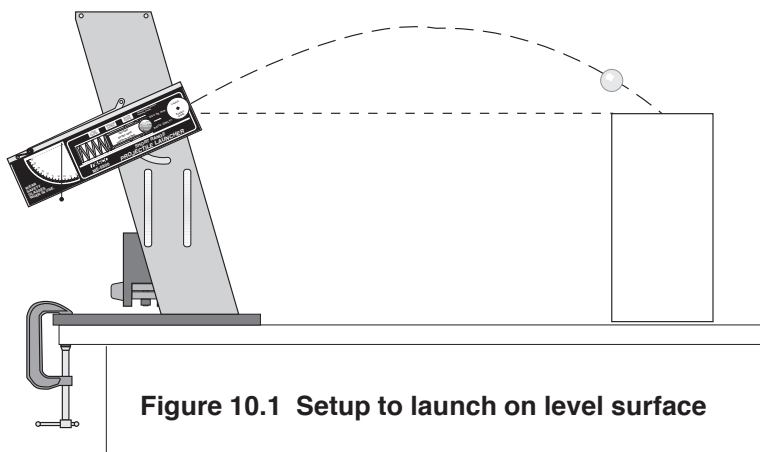

Figure 10.1 Setup to launch on level surface

Procedure

- ① Launch the ball at 30 degrees to demonstrate that the ball lands on the box.
- ② Change the angle of the launcher to 60 degrees and launch the ball again. Call attention to the fact that the ball again lands on the box. Thus the ranges are the same.
- ③ Change the angle to 45 degrees and launch the ball again to show that the ball now lands further away, missing the box.
- ④ Ask the question: What other pairs of angles will have a common range? This demonstration can be done for any two angles which add up to 90 degrees: 20 and 70, or 35 and 55, etc.

Experiment 11 (Demo): Simultaneously Launch Two Balls Horizontally at Different Speeds

EQUIPMENT NEEDED

- (2) Projectile Launchers and (2) plastic balls

Purpose

The purpose of this demonstration is to show that regardless of the initial speed of the balls launched horizontally off a table, the balls will hit the floor at the same time.

Theory

Two balls are launched horizontally from the same table (from the same height, y). The muzzle speeds of the two balls are different.

The vertical and horizontal motions of a projectile are independent of each other. The horizontal distance, x , travelled by the ball is dependent on the initial speed, v_0 , and is given by $x = v_0 t$, where t is the time of flight. The time of flight depends only on the vertical distance the ball falls since $y = \frac{1}{2} g t^2$. Since the vertical distance is the same each ball, the time of flight must be the same for each ball.

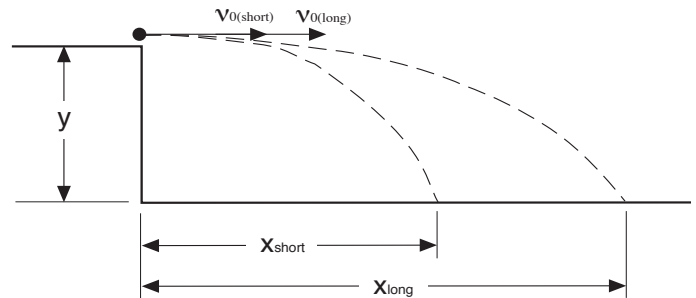

► **NOTE:** For best results, see the notes on "Repeatable Results" in the Introduction.

Setup

- ① Clamp two Projectile Launchers adjacent to each other on a sturdy table. The launchers should both be aimed in the same direction, away from the table so the balls will land on the floor.
- ② Adjust the angle of each Projectile Launcher to zero degrees so the balls will be launched horizontally off the table.

Procedure

- ① Put a plastic ball into each Projectile Launcher and cock one launcher to the short range position and cock the other launcher to the long range position.
- ② Ask the class to be quiet and listen for the balls striking the floor. Tell them if they hear only one click, that means the balls hit the floor simultaneously.
- ③ Put both lanyards in the same hand and pull them at the same time so the balls are launched simultaneously.
- ④ After the balls hit the floor, ask the class if they heard one click or two.

Experiment 12 (Demonstration): Launching Through Hoops

EQUIPMENT NEEDED

- Projectile Launcher and plastic ball
- (2) Photogates
- 2-meter stick
- 5 ring clamps on stands
- Photogate Mounting Bracket

Purpose

The purpose of this demonstration is to show that the path of a ball launched horizontally from a table is parabolic.

Theory

The range is the horizontal distance, x , between the muzzle of the launcher and the place where the ball hits, given by

$$x = v_0 t$$

where v_0 is the initial speed of the ball as it leaves the muzzle and t is the time of flight.

The vertical position, y , of the ball at time t is given by

$$y = y_0 - \frac{1}{2} g t^2$$

where y_0 is the initial height of the ball and g is the acceleration due to gravity.

► **NOTE:** For best results, see the notes on "Repeatable Results" in the Introduction.

Setup

- ① Before the demonstration begins, find the initial velocity for the range setting to be used. Attach the photogates and use a computer to find the initial velocity or launch the ball horizontally and measure x and y to find the initial velocity. See experiments 1 and 2.
- ② To prepare to demonstrate, clamp the Projectile Launcher to the demonstration table with the launcher aimed away from the table so the ball will land on the floor.
- ③ Adjust the angle of the launcher to zero degrees so it will launch horizontally.

Procedure

- ① In front of the class, measure the initial height of the ball at muzzle level.
- ② Calculate the horizontal and vertical positions of the ball each 1/10 second until it hits the floor.

t (sec)	$x = v_0 t$ (cm)	$y = y_0 - (1/2)gt^2$ (cm)
0.1		
0.2		
0.3		
0.4		
0.5		

- ③ Lay the 2-meter stick on the floor in a straight line away from the launcher. Remove the back mounting screw from the launcher base so the back of the launcher can be rotated upward. Look through the back of the launcher and align the sights and the end of the 2m stick so the 2m stick is aligned with the path of the ball. Relevel the launcher.
- ④ Measure off each set of x and y and place a ring clamp on a stand at each position (See Figure 12.1). If possible it is best to adjust the last two ring stands at an angle from the vertical so the ball will not have to pass through them at an oblique angle. A cup may be placed at the end of the path to catch the ball.
- ⑤ Launch the ball through the rings.
- ⑥ Ask the class what shape of curve is formed by the rings.

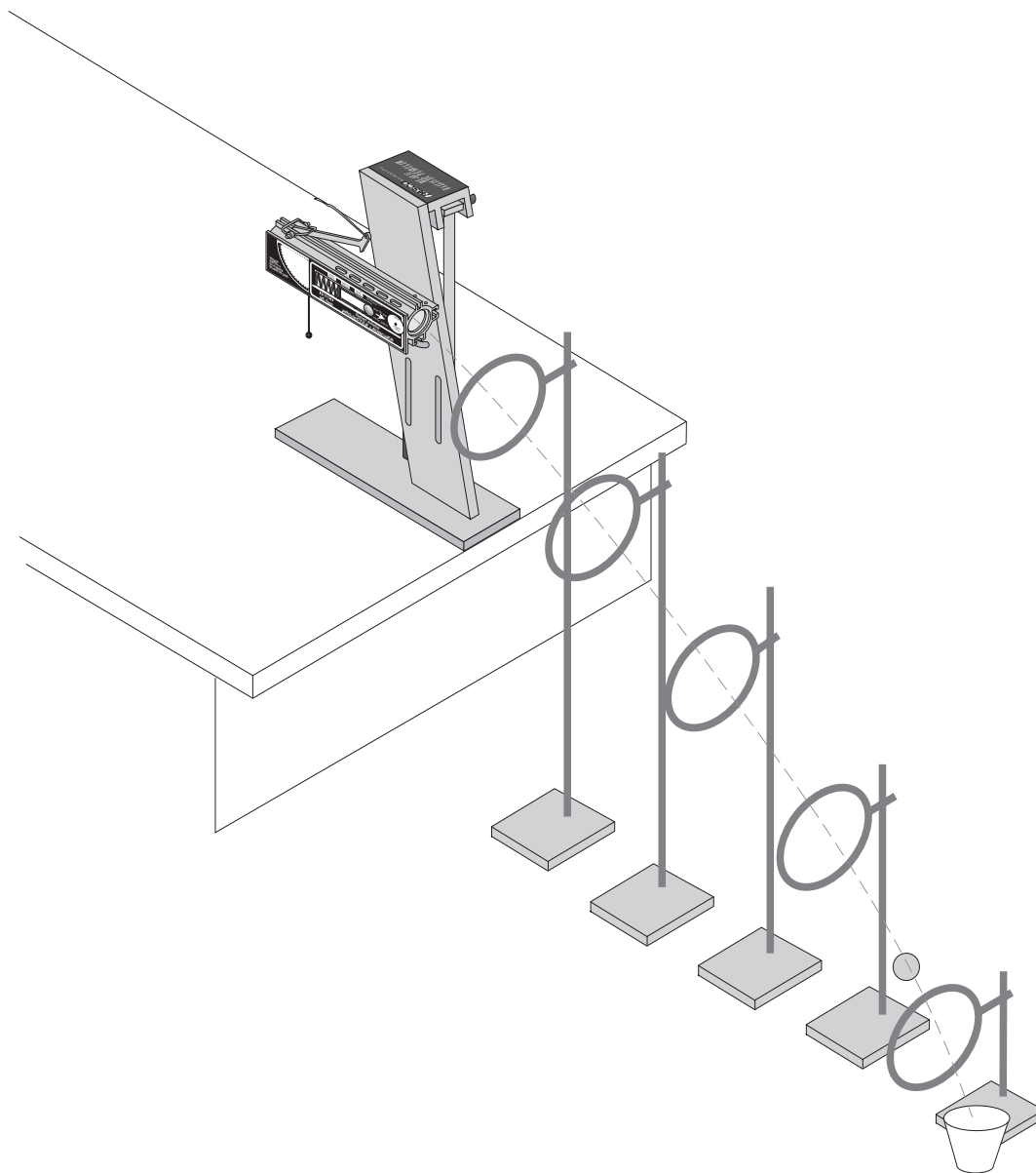

Figure 12.1 Placing the rings

Experiment 13: (Demonstration): Elastic and Inelastic Collisions

EQUIPMENT NEEDED:

- Projectile Launcher
- plastic or steel ball
- Ballistic Pendulum

Purpose

The purpose of this demonstration is to show the difference in kinetic energy transfer between an elastic and an inelastic collision.

Theory

The amount of kinetic energy transferred between colliding objects depends on the elasticity of the collision. By reversing the pendulum so that the ball bounces off instead of catching, it is possible to demonstrate this effect.

Procedure

- ① Fire the ball into the pendulum and record the angle reached.
- ② Remove the pendulum, and reinstall it in the reversed position (ball opening away from launcher)
- ③ Fire the same ball at the same launcher setting and note the angle reached. The collision between ball and pendulum is not perfectly elastic, so kinetic energy is still not conserved. However, the collision is more nearly elastic than the completely inelastic collision in step 1, so there will be a greater transfer of kinetic energy.

Teachers Guide

Experiment 1: Projectile Motion

Procedure

► **NOTE:** For best results, make sure that the projectile launcher is clamped securely to a firm table. Any movement of the gun will result in inconsistent data.

A) The muzzle velocity of the gun tested for this manual was 6.5 m/s (Short range launcher at maximum setting, nylon ball)

B) To find the range at the chosen angle, it is necessary to solve the quadratic equation given in the theory section. You may wish for the students to do this, or you may provide them with the solution:

$$t = \frac{v_0 \sin \theta + \sqrt{(v_0 \sin \theta)^2 + 2g(y_0 - y)}}{g}$$

Analysis

① The difference depended on the angle at which the gun was fired. The following table gives typical results:

Angle	Predicted Range	Actual Range	Percent Error
30	5.22	5.19	0.57%
45	5.30	5.16	2.64%
60	4.35	4.23	2.87%
39	5.39	5.31	1.48%

► **NOTE:** The maximum angle is not 45° in this case, nor is the range at 60° equal to that at 30°. This is because the initial height of the ball is not the same as that of the impact point. The maximum range for this setup (with the launcher 1.15 m above ground level) was calculated to be 39°, and this was experimentally verified as well.

② Answers will vary depending on the method of estimating the precision. The primary source of error is in ignoring the effect of air resistance.

Experiment 2: Projectile Motion Using Photogates

► **NOTE:** Other than the method of determining initial velocity, this experiment and experiment 1 are equivalent.

Experiment 3: Projectile Range Versus Angle

Procedure

Launching off a level surface:

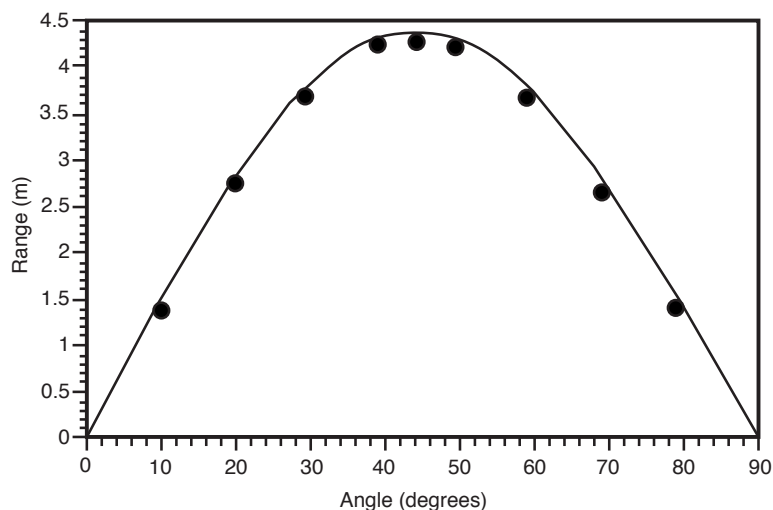

Launching off a table:

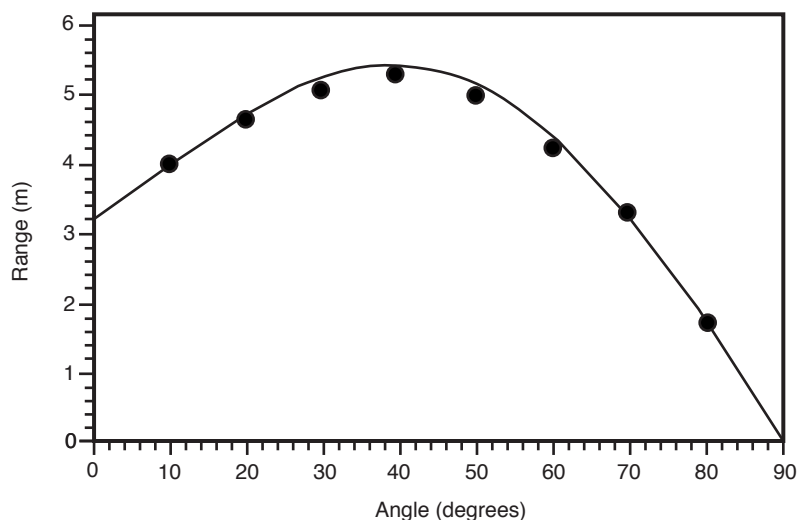

► **NOTE:** The curves shown are for the calculated ranges in each case. The data points are the actual measured ranges.

Questions:

- ① On a level surface, the maximum range is at 45° . For a non-level surface, the angle of maximum range depends on the initial height of the projectile. For our experimental setup, with an initial height of 1.15 m, the maximum range is at 40° . (Theoretical value 39°)
- ② The angle of maximum range decreases with table height.
- ③ The maximum distance increases with table height.

Experiment 4: Projectile Path

Analysis

- ① Alternately, measure your distances from the ground up.
- ③ Vertical distances measured from the ground up for this graph. The intercept is the height of the launcher above ground when done this way.

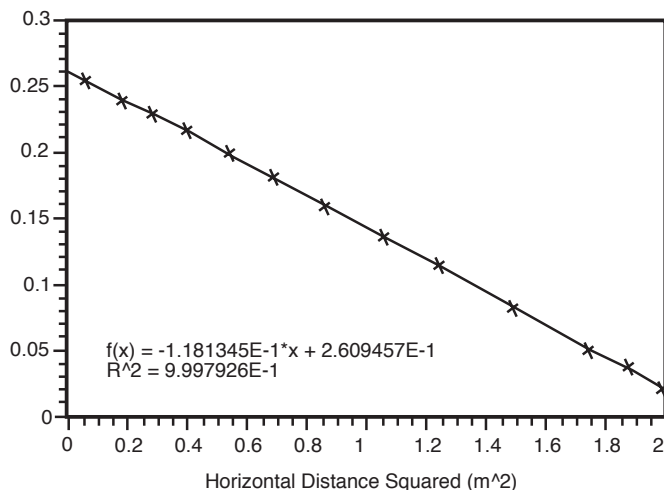

- ④ The slope (measuring from the ground) is -0.118 for this test. (Measuring down from the initial height will give the same value, only positive.) In either case, the slope is

$$\frac{g}{2v_0^2}$$
- ⑤ The slope calculated here gives us an initial velocity of 6.44 m/s. This compares favorably with the velocity calculated in experiments 1 and 2.
- ⑥⑦ Results will vary with this method: the point of the exercise is that individual measurements are not as accurate as a large number of measurements and a curve fit.

Questions

- ① Yes. This tells us that y is a function of x^2 .
- ② A plot of y versus x would be parabolic instead of linear.
- ③ The projectile moves in a parabolic curve. (neglecting air friction)

Experiment 5: Conservation of Energy

Analysis

- ① Using the photogate method, we found that the initial speed of the ball was 4.93 m/s. (Nylon ball, short range launcher at medium setting) The ball mass was 9.6 g, so our total kinetic energy was 0.117 J.
- ② The ball reached an average height of 1.14 m. Potential energy was then 0.107 J.
- ③ Energy lost was 8.5% of original energy.

► **NOTE:** It seems rather unlikely that this much energy is lost merely to air resistance; especially when one considers the extraordinarily good results on labs 3 and 4. It is more likely that the error here enters the calculations in the actual measurement of initial velocity and height.

Experiment 6: Conservation of Momentum in Two Dimensions

Setup

- ② It is best to arrange things so that you can use medium range rather than short. The medium-range setting gives more predictable results than the short-range setting.

Analysis

- ④⑥ Results for the x component of momentum should be within 5% of initial values. The total y component should be small compared to the x component; percent deviation may not be a valid indication of accuracy.

Questions

- ①② Momentum is conserved on both axes.
- ③ Kinetic energy is nearly conserved in the elastic collision. There is some loss due the fact that the collision is not completely elastic.
- ④ Energy is conserved for the inelastic collision; but kinetic energy is not.
- ⑤ The angle should be nearly 90°. (Our tests had angles of about 84°)
- ⑥ In the inelastic case, the angle will be less than in the elastic case. The exact angle will depend on the degree of inelasticity, which will depend on the type and amount of tape used.

Experiment 7: Varying Angle to Maximize Height on a Wall

Procedure

- ① You should be able to measure the angle of maximum height to within 2% either way.
- ④ Measure the distance to the front edge of the ball.
- ⑤ Measure the initial height to the center of the ball.

Analysis

- ① The initial velocity should be close to the initial velocity determined by other methods. You may wish to determine the initial velocity by the method in lab 1, and use that value in your calculations for the rest of this experiment.
- ③ Measured and calculated should agree to within 3%.

Questions

- ① The ball will have passed its peak by the time it reaches the wall. To show this, take the derivative of y with respect to x :

$$y = y_0 + x \tan \theta_{\max} - \frac{gx^2}{2v_0^2 \cos^2 \theta_{\max}}$$

$$\frac{dy}{dx} = \tan \theta_{\max} - \frac{gx}{v_0^2 \cos^2 \theta_{\max}}$$

$$\text{Substitute } \theta_{\max} = \tan^{-1} \left(\frac{v_0^2}{gx_{\max}} \right)$$

$$\frac{dy}{dx} = \frac{v_0^2}{gx_{\max}} - \frac{gx}{v_0^2 \cos^2 \left[\tan^{-1} \left(\frac{v_0^2}{gx_{\max}} \right) \right]}$$

$$\text{Substitute } \cos \left[\tan^{-1} \left(\frac{a}{b} \right) \right] = \frac{b}{\sqrt{a^2 + b^2}} \text{ and simplify.}$$

$$\frac{dy}{dx} = \frac{v_0^2}{gx_{\max}} - \frac{gx}{v_0^2 \left(\frac{gx_{\max}}{\sqrt{v_0^4 + g^2 x_{\max}^2}} \right)^2} = \frac{v_0^2}{gx_{\max}} - \frac{x(v_0^4 + g^2 x_{\max}^2)}{v_0^2 + gx_{\max}^2}$$

$$\frac{dy}{dx} = \frac{v_0^2}{gx_{\max}} - \frac{v_0^2 x}{gx_{\max}^2} - \frac{xg}{v_0^2}$$

When $x = x_{\max}$, the value of this derivative is negative.

$$\left. \frac{dy}{dx} \right|_{x_{\max}} = -\frac{gx_{\max}}{v_0^2}$$

- ② Solve the equation for maximum angle to determine x .

$$\tan \theta_{\max} = \frac{v_0^2}{gx} \Rightarrow x = \frac{v_0^2}{g}$$

Substitute this value into the equation for y to determine the maximum height.

$$y = y_0 + \frac{v_0^2}{g} - \frac{g \left(\frac{v_0^2}{g} \right)}{v_0^2} = y_0 + \frac{v_0^2}{g} - \frac{v_0^2}{g}$$

$$y = y_0$$

Experiment 8: Projectile Velocity—Approximate Method

Procedure

- ② The exact mass used is not critical. Pick a value that gives a fairly large swing for best results.
- ⑤ With the steel ball and extra masses on the pendulum, the balance point will be somewhere on the catcher block itself. This makes it difficult to use string, but it is easy to find the center of mass by balancing the pendulum on a straightedge.
- ⑧ The angle reached by the pendulum should not vary more than 1° between successive trials at most.

Calculations

- ② Use the equation given in the theory section for the approximate method.

Questions

- ① The best other method of measuring velocity is described in the first part of experiment 1.
- ② The greatest source of error is the equation used. This is an approximate equation, based on the assumption that the masses involved are point masses. The amount of effect this equation has on the results will depend on the exact geometry of the pendulum and ball, and should be between 5-8%.
- ③ Typically, 70% of the kinetic energy of the ball is lost. It is not valid to assume that KE is conserved!
- ④ More energy is transferred in a more elastic collision.

Experiment 9: Projectile Velocity—Exact Method

Procedure

- ② The exact mass used is not critical. Pick a value that gives a fairly large swing for best results.
- ⑤ With the steel ball and extra masses on the pendulum, the balance point will be somewhere on the catcher block itself. This makes it difficult to use string, but it is easy to find the center of mass by balancing the pendulum on a straightedge.
- ⑧ Measure this period as exactly as possible, using the smallest measurement angle that is practical.
- ⑪ The angle reached by the pendulum should not vary more than 1° between successive trials at most.

Calculations

- ② Use the equation given in the theory section for the exact method.

Questions

- ① The best other method of measuring velocity is described in the first part of experiment 1.
- ② Sources of error include friction, measurement error, and Murphy's Law.
- ③ Typically, 70% of the kinetic energy of the ball is lost. It is not valid to assume that KE is conserved!
- ④ The energy transfer is less efficient when there is a larger difference in the masses involved.
- ⑤ The approximate method will give results that are typically 5-7% higher than their actual values. The more "pointlike" the mass of the pendulum, the more accurate the approximate method.

Technical Support

Feedback

If you have any comments about the product or manual, please let us know. If you have any suggestions on alternate experiments or find a problem in the manual, please tell us. PASCO appreciates any customer feedback. Your input helps us evaluate and improve our product.

To Reach PASCO

For technical support, call us at 1-800-772-8700 (toll-free within the U.S.) or (916) 786-3800.

fax: (916) 786-3292

e-mail: techsupp@pasco.com

web: www.pasco.com

Contacting Technical Support

Before you call the PASCO Technical Support staff, it would be helpful to prepare the following information:

- ▶ If your problem is with the PASCO apparatus, note:
 - Title and model number (usually listed on the label);
 - Approximate age of apparatus;
 - A detailed description of the problem/sequence of events (in case you can't call PASCO right away, you won't lose valuable data);
 - If possible, have the apparatus within reach when calling to facilitate description of individual parts.
- ▶ If your problem relates to the instruction manual, note:
 - Part number and revision (listed by month and year on the front cover);
 - Have the manual at hand to discuss your questions.

