

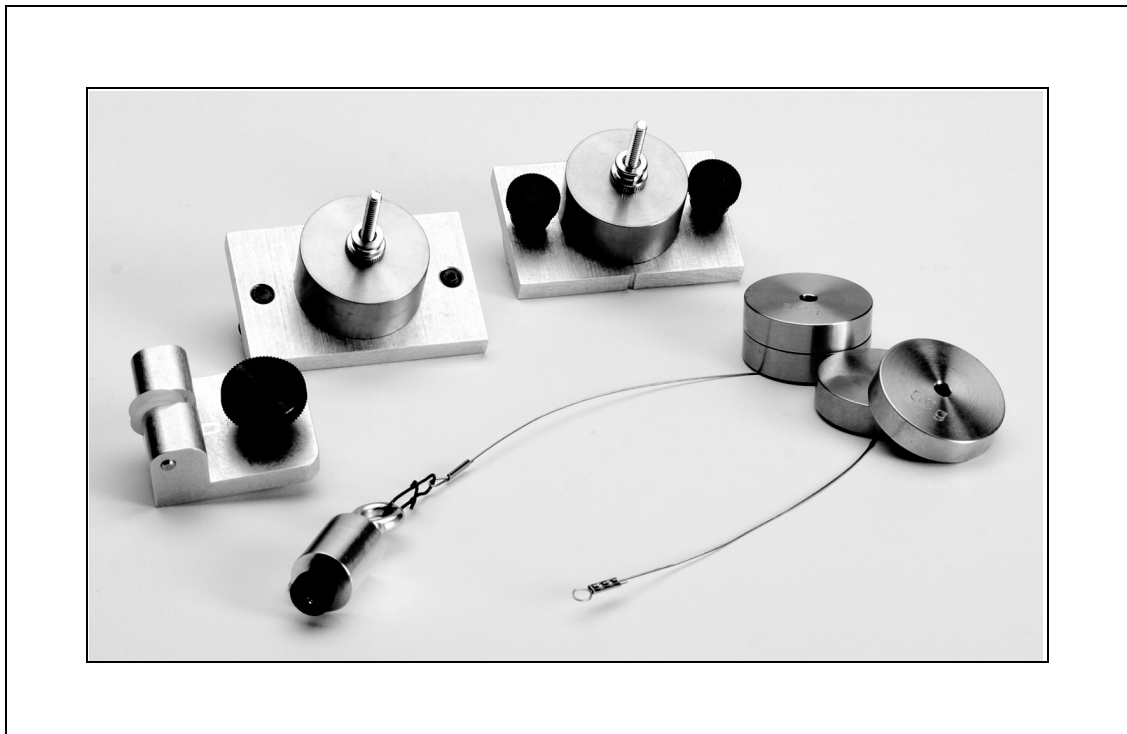

# Computer-Based Centripetal Force Accessory

Model No. ME-8089



## Table of Contents

<b>Equipment List</b> .....	<b>3</b>
<b>Introduction</b> .....	<b>4</b>
<b>Equipment Setup</b> .....	<b>4-7</b>
<b>Suggested Experiment</b> .....	<b>7-10</b>
Part I: Centripetal Force vs. Velocity.....	7-9
Part II: Centripetal Force vs. Mass.....	9
Part III: Centripetal Force vs. Radius.....	10
<b>Sample Data/Results</b> .....	<b>10</b>
<b>Appendix A: DataStudio Setup Instructions</b> .....	<b>11</b>
<b>Appendix B: Technical Support</b> .....	<b>12</b>
<b>Appendix C: Copyright and Warranty Information</b> .....	<b>12</b>

# Computer-Based Centripetal Force Accessory

Model No. ME-8089

## Equipment List

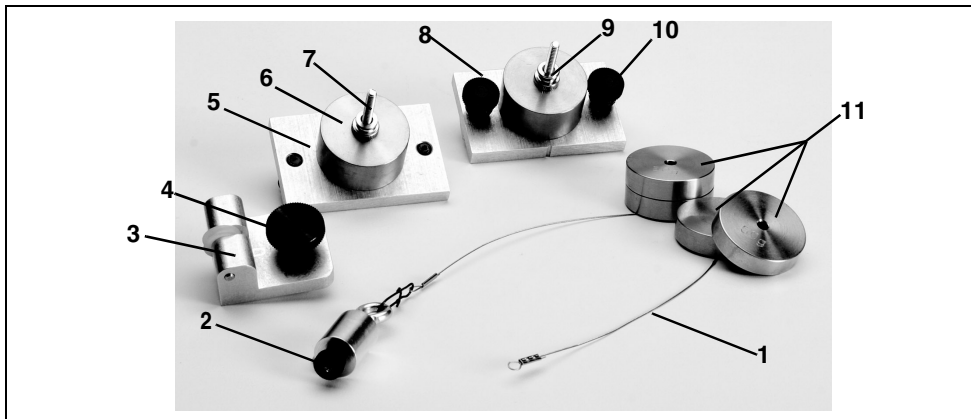

Included Equipment	Model Number	Additional Equipment Required	Model Number
1. Connecting Cable (1)	623-038	Rotating Platform	ME-8951
2. Ball Bearing Swivel, 12.5 g (1)	648-08386	A computer	N/A
3. Pivot block (1)	648-08422	DataStudio <sup>®</sup> Software	See PASCO catalog.
4. Thumbscrew for Pivot Block (1)	617-003	Computer Interface	PASPORT <sup>™</sup> * or ScienceWorkshop <sup>®</sup> **
5. Sliding Mass Holder (1)	648-08423	Force Sensor	PS-2104* or CI-6746**
6. Mass, 100 g (2)	648-06511	Photogate Head/Port	ME-9498A, PS-2123*
7. Screws for Mass Holders (2)	610-246	Steel Rod (45 and 90 cm or 120 cm)	ME-8736/ME-8738/ME-8741
8. Stationary Mass Holder (1)	648-08424	Multi-Clamp	SE-9442
9. Nuts for Mass Holders (2)	614-006	Large Rod Base (2)	ME-8735
10. Thumbscrews (2)	613-067	Experiment Setup Disk	013-08425A
11. Mass, 50 g (4)	648-06510		

\*PASPORT<sup>™</sup> sensors (with PS-prefix) require a PASPORT<sup>™</sup> interface PS-2100(2) or PS-2001(1) for operation. A Photogate Port (PS-2123) is required for photogate use with PASPORT interfaces.

\*\*ScienceWorkshop<sup>®</sup> sensors (with CI-prefix) require a ScienceWorkshop<sup>®</sup> interface for operation.

**Optional equipment:** For constant speed studies, a Motor Drive (ME-8955) with DC Power Supply (SF-9584A) is recommended.

## Introduction

PASCO's Computer-Based Centripetal Force Accessory (ME-8089) allows students to investigate the relationships between centripetal force, radius, mass, and velocity for an object undergoing uniform circular motion. Traditional experiments in this area involve the swinging of masses above the head. The traditional approach is difficult to execute and data is rarely sufficient for an understanding of the relationships. With a computer interface, Force Sensor, and photogate, the Computer-Based Centripetal Force Accessory removes these difficulties by allowing the student to directly measure and observe the force and velocity of the mass as it rotates.

Masses are included with the apparatus to facilitate a range of mass trials. The sliding and stationary mass holders provided with the accessory attach to a PASCO Rotating Platform (ME-8951). Spinning the Rotating Platform and allowing it to slow down (without assistance) varies the velocity. The platform can be manually spun by hand or automatically with a Motor Drive (ME-8955) and DC power supply. Sliding the captured masses along the grooves in the rotating platform changes the radius. For radius measurements, a convenient measuring scale is included on the top edge of the platform.

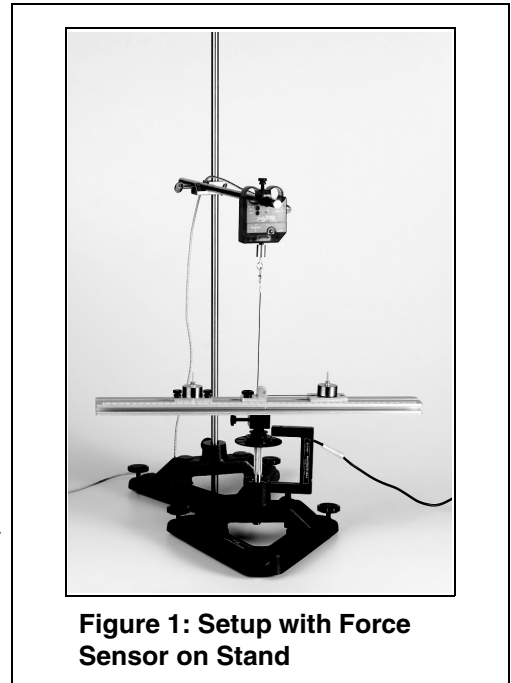

**Figure 1: Setup with Force Sensor on Stand**

## Equipment Setup

1. Insert the photogate post into the base stand and into the photogate head.
2. Use a thumbscrew to mount a Photogate Head (ME-9498A) to the bottom of the "A" base (See Figure 2). Let the Photogate Head rest over the first ring on the 3-step pulley of the Rotating Platform. (**Note:** Ensure that the positioning of the photogate does not restrict movement of the shaft).
3. Connect the photogate to a computer interface (*ScienceWorkshop* or *PASPORT*).

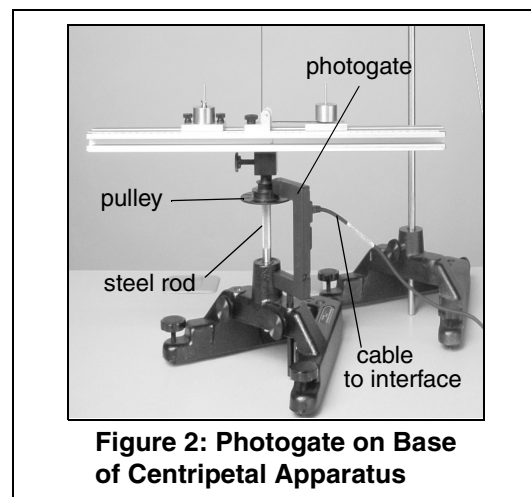

**Figure 2: Photogate on Base of Centripetal Apparatus**

**Note:** If using a PASPORT interface, connect the photogate to a PASPORT Photogate Port.

4. Slide the pivot block through the groove to the center of the platform. (Note: The indent mark on the pivot block must face the zero position on the measuring tape.) Tighten in place.
5. Slide the fixed mass holder onto the platform. Slide the nuts into the T-slot and tighten the thumbscrews over the nuts.
6. Insert the sliding mass holder through the groove on the top of the platform, such that the side indent faces the measuring tape.
7. Mount a 90 cm stainless steel rod vertically into a second “A” base stand.
8. Attach a Multi-Clamp to the upper end of the stainless steel rod (See Figure 3a).
9. Insert the shorter stainless steel rod (45 cm) horizontally into the Multi-Clamp.

**Note:** With an additional rod and clamp, you can insert another rod into the base stand and a longer crossbar(rod) into the clamp. This creates a more stable structure.

10. Slide a Force Sensor onto the stainless steel rod and adjust the top screw to anchor it to the rod (Figure 3a). (Note: Be sure to keep the cords from the sensor out of the path of the rotating arm.)
11. Attach the ball bearing swivel to the bottom of the Force Sensor.

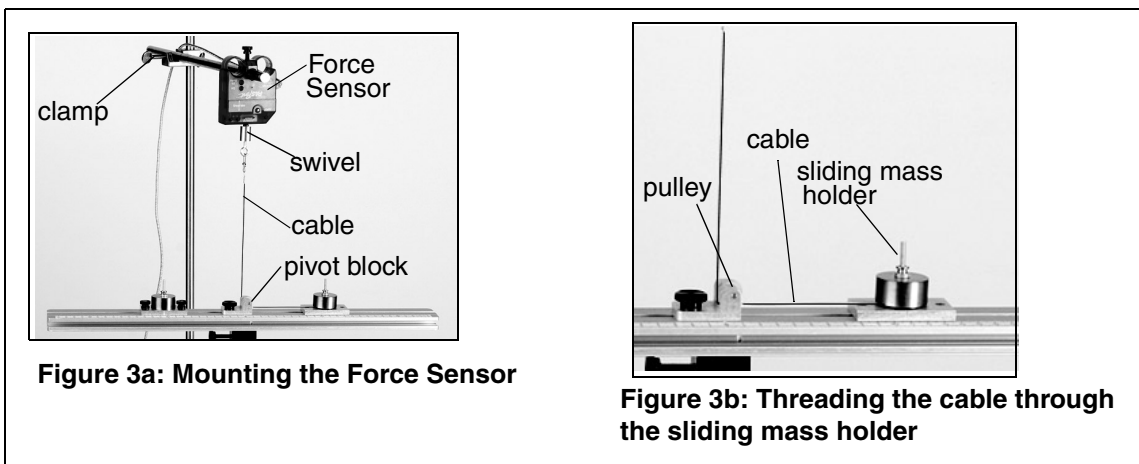

12. Thread the cable from the swivel hook through the pulley and over the screw of the “sliding mass” holder (Figure 3b).
13. Move the Force sensor directly over the pivot block in the center of the platform. (**Note:** You can adjust the radius of the sliding mass holder by moving the crossbar higher or lower.)

**Note:** Always lay down the cable *before* adding the mass.

14. Add a mass over the cable on the sliding mass holder; then tightly screw on the knurled nut to hold the mass in place (Figure 4).
15. Add a mass to the fixed mass holder and use a knurled nut to hold the mass in place. (**WARNING:** Keep the thumbscrews tight or the mass holder will slide off during the rotation.)

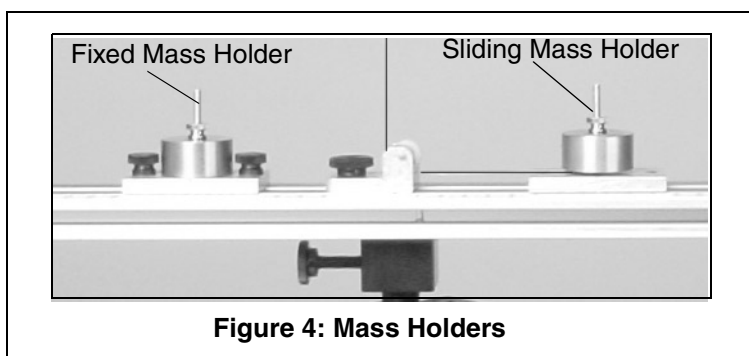
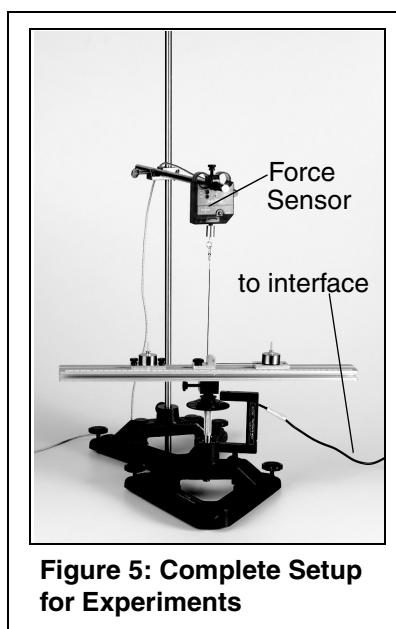

**Figure 4: Mass Holders**

16. Move both the fixed and sliding mass holders the same distance from the center on the platform (You can choose any arbitrary radius).
17. Plug the Force Sensor into a a PASPORT or *ScienceWorkshop* computer interface.

**CAUTION:** Keep all cords away from the rotating arm. The rotating arm must be free to move 360 degrees without hitting any objects in its path.

 **WARNING:** Do not stand next to rotating arm or look at the rotating arm at eye level. To avoid possible injury from the rotating arm hitting the body, keep at least 1 foot distance from the rotating arm.



**Figure 5: Complete Setup for Experiments**

18. Open the appropriate DataStudio file on the experiment setup disk.
19. Launch DataStudio and click the **Start** button to begin collecting data.



**Note:** To calibrate the *ScienceWorkshop* Force Sensor, follow the instructions provided in the documentation included with your Force Sensor or in the DataStudio online help. Calibration of the PASPORT Force Sensor is not required. However, you can tare the PASPORT Force Sensor by pressing the **Zero** button without any weight attached.



**Note:** PASCO's PASPORT Force Sensor (PS-2104) requires a PASPORT interface; PASCO's *ScienceWorkshop* Force Sensor (CI-6746) requires a *ScienceWorkshop* interface.



**Note:** DataStudio setup instructions (for either PASPORT or *ScienceWorkshop* sensors) are available in Appendix A.

### Attaching a Motor Drive with Power Supply (Optional)

If you plan to do a constant speed experiment, you may want to consider purchasing a motor drive. A motor drive requires a DC power supply or function generator for operation. The instructions for mounting the drive are included with the apparatus. Figure 6 shows a picture of a motor drive attached to the 3-step pulley.

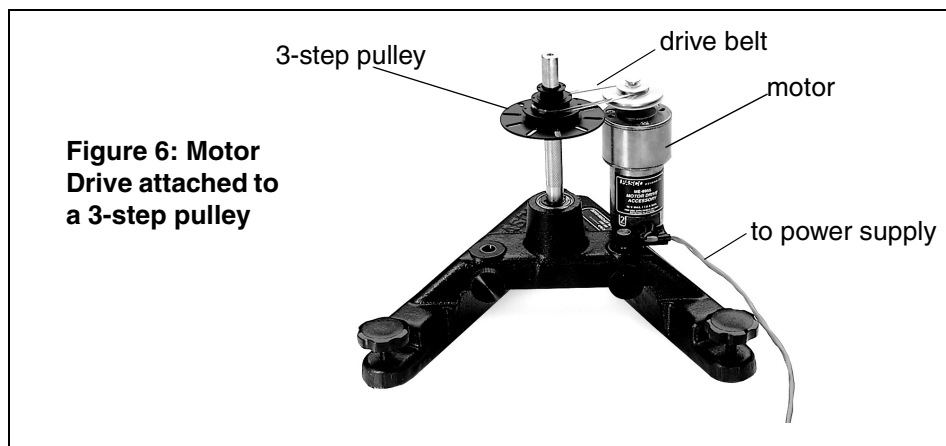

PASCO's Motor Drive (ME-8955) comes with a drive belt for connecting the motor drive to the pulley.

## Suggested Experiment: Centripetal Force and Velocity

Equipment Required	
Rotating Platform (ME-8951)	Computer interface ( <i>ScienceWorkshop</i> or PASPORT)
Force Sensor (PS-2104* or CI-6746**)	DataStudio Software (ver. 1.5 or higher)
Photogate Head (ME-9498A) and/or Photogate Port (PS-2123)*	Base support, clamps, and mounting rods

\*PASPORT sensors (with PS-prefix) require a PASPORT interface [PS-2100(2) or PS-2001(1)] for operation. A Photogate Port (PS-2123) is required for photogate use with PASPORT interfaces.

\*\**ScienceWorkshop* sensors (with CI-prefix) require a *ScienceWorkshop* interface (CI-6400 or CI-6450 or CI-7450) for operation.

Optional: For constant speed studies, a Motor Drive (ME-8955) with a DC power supply (SF-9584A) is recommended.

### Part I: Centripetal Force vs. Velocity

In Part I of this experiment, you will *vary the velocity* by spinning the platform to a high, safe velocity. The velocity decreases over time as the centripetal force is continuously measured by the Force Sensor. The radius and mass are held constant as the velocity decreases.

## Setup

Follow the equipment setup instructions on pages 4-7 of this manual. Use the appropriate DataStudio setup file on the experiment disk or the DataStudio setup instructions in Appendix A.

## Experiment Tips

a) To add mass to the “sliding mass” holder, lay the components over the attachment screw in the following order: a) cable b) mass and c) nut to tighten.

**Note:** Do not place the mass underneath the cable, as this will interfere with a proper measurement.

- b) Place an equal amount of mass on the “fixed mass” and “sliding mass” holders.
- c) Be sure to place the “fixed mass” at the same radius as the “sliding mass” to ensure balancing of the unit as it rotates.
- d) To add the “sliding mass,” lay the components over the attachment screw in the following order: a) cable b) mass and c) nut and d) thumbscrews to tighten.
- e) The velocity of the “sliding mass” can be measured as an angular velocity. In DataStudio, use a Graph display to monitor the velocity of the rotating mass. If velocity readings do not appear, check your photogate connection and DataStudio setup (See Appendix A).
- f) To vary the radius, adjust the position of the Force Sensor (See Figure 1-3.)
- g) If the rotating arm does not move, there may be too much friction in the cable or the pulley and turning rod may be too tight. Move the Force Sensor down to loosen the cable or adjust the turning rod.

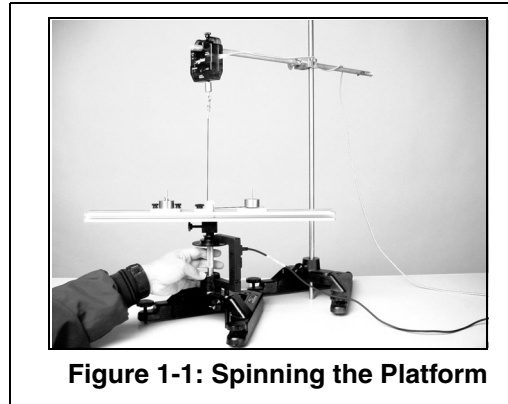

Figure 1-1: Spinning the Platform

## Experiment Procedure

1. Place 100 g mass on each mass holder and secure with the thumbscrews.
2. Adjust the position of the fixed and sliding mass to about 20 cm (Note: The maximum radius is 22 cm. To adjust the position, pull outward on the mass to tighten the wire.)
3. Set up your experiment in DataStudio. Set the smart pulley on angular speed (rad/sec) and create two equations: Force = -smooth (10, F) and speed squared =  $V^2$ . Set the sample rate to 10 Hz. (For more information, see Appendix A.)
4. With the knurled shaft, spin the rotating platform (by hand) to about 6 radians/second (1 or 2 Hz) and let go.



5. In DataStudio, click the **Start** button and watch the Force vs. Speed graph as the platform speed decreases. When the speed falls below 2 radians/second, click the **Stop** button.

### Analysis:

1. Explain the shape of the force vs. velocity graph.
2. Create a graph of Force vs. Speed Squared. Does the graph show a straight line? Why or why not? Find the slope.
3. Calculate the theoretical slope for  $F = mr\omega^2$  where the slope is  $mr$ . Calculate the slope using your values of  $m$  and  $r$ . Calculate the percent (%) difference between the two values.

### Part II: Centripetal Force vs. Mass

In Part II, the radius and velocity are held constant as the mass is varied. Adding extra drilled masses to the mass holder increases the mass of the system. Equal amounts of mass must also be added to the “fixed mass” to balance the arm as it rotates. Centripetal force is directly measured by the Force Sensor.

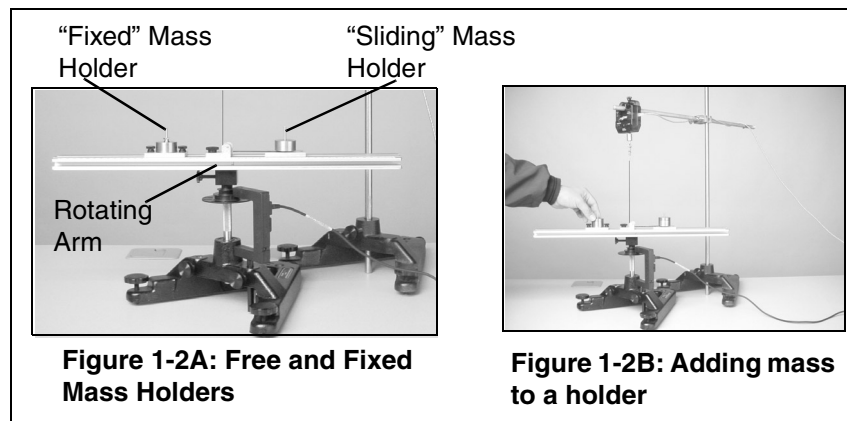

Perform several different data runs, each time varying the mass on the sliding and fixed mass holders. (The mass holder is about 50 g. The mass can be varied from 50 to 250 g in 50 g increments.) (**Note:** Keep the speed constant. A motor drive with power supply can be used to ensure a constant speed. Otherwise, spin the platform with your hand above some set speed and start recording. When the platform slows down below the set speed, stop recording.) Use a graph or table to record the force at a set speed. Repeat the experiment for the other masses and make an editable graph of the Force vs. Mass.

### Part III: Centripetal Force vs. Radius

In Part III, the velocity and mass are held constant as the *radius is varied*. Lowering the Force Sensor increases the radius. As the radius increases, the “fixed mass” must be moved to a matching radius to balance the rotating arm. Again, centripetal force is measured by the Force Sensor. Repeat the experiment at different radii (i.e. vary the radius from 22 cm to 8 cm in 2 cm steps). Use a graph or table to record the force at the set speed. In DataStudio, make an editable graph of the Force vs. Radius.

**Note:** If force readings do not appear in DataStudio, check your sensor-to-interface connections and setup in DataStudio. See Appendix A of this manual.

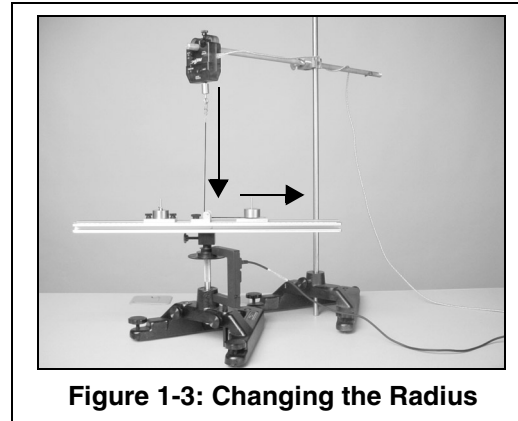
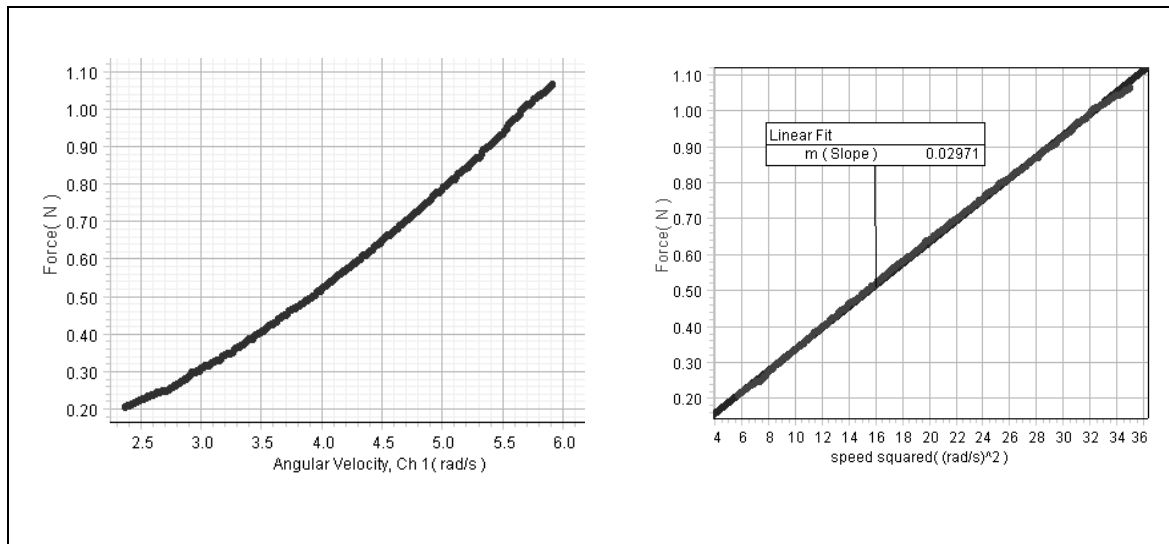

Figure 1-3: Changing the Radius

### Sample Data/Results (for Part I)



## Appendix A: DataStudio Setup Instructions

An experiment setup disk is included (with the ME-8089) for setting up the experiments in this manual. The setup disk also contains DataStudio files for experiments involving linear velocity. (The instructions below are for those wishing to create the DataStudio setup files.)

Procedure	Steps
<b>PART I:</b> Plug the sensors into the interface:	<p><b>PASPORT:</b> <b>a)</b> Plug the Photogate into either channel 1 or 2 on a PASPORT Photogate Port. <b>b)</b> Plug both the Photogate Port and Force Sensor into a PASPORT interface (i.e. USB Link, Xplorer, PowerLink, etc.).</p> <p>OR</p> <p><b>ScienceWorkshop:</b> <b>a)</b> Plug the Photogate into a digital channel on the <i>ScienceWorkshop</i> interface. <b>b)</b> Plug the Force Sensor into any analog channel (A, B, or C) on the <i>ScienceWorkshop</i> interface.</p>
<b>PART II:</b> Set up your experiment	<p><b>PASPORT:</b> <b>a)</b> Open DataStudio and select "Create Experiment." <b>b)</b> On the main toolbar, click the <b>Setup</b> button to open the Experiment Setup window. <b>c)</b> When the Experiment Setup dialog opens, click on the <b>Add Timer</b> button, select the Smart Pulley (Rotational) icon, accept the default spoke angle spacing, and click OK. <b>d)</b> In the Setup window, scroll to the Force Sensor and select "pull, positive." Keep the sample rate at 10 Hz.</p> <p>OR</p> <p><b>ScienceWorkshop:</b> <b>a)</b> Open DataStudio and select "Create Experiment." <b>b)</b> On the main toolbar, click the <b>Setup</b> button to open the Experiment Setup window. <b>c)</b> In the Sensors list of the Experiment Setup window, click and drag the Smart Pulley icon and Force sensor icons to the picture on the interface (the same channels into which the sensors are plugged). <b>d)</b> Double click on the Smart Pulley icon. In the Measurement tab, select angular velocity (radians/sec). <b>e)</b> Double click on the Force Sensor icon and set the sample rate to 10 Hz.</p>
<b>PART III:</b> Create your equations	<p><b>a)</b> Click on the <b>Calculate</b> button to open the Calculator dialog. In the Calculator dialog, click the <b>New</b> button.</p> <p><b>b)</b> Force equation: In the equation box, type in the equation <math>F = -\text{smooth}(10, F)</math>. Use the Special menu to select the Smooth function and replace the default values with 10, F. Under Variables, click the arrow, select data measurement, Force(N), and click <b>OK</b>. Click the <b>Accept</b> button.</p> <p><b>c)</b> Speed equation: Click the <b>New</b> button. Type in the equation <math>\text{speed squared} = v^2</math>. Under variables, click on the arrow, select "data measurement," "velocity," and click <b>OK</b>. Click the <b>Accept</b> button to accept the equation. )To edit the equation, double click on the equation icon in the Data list.</p>
<b>PART IV:</b> Collect Data	<b>a)</b> Open a display and click the <b>Start</b> button on the main toolbar.

## Appendix B: Technical Support

For assistance with the ME-8089 Computer-Based Centripetal Force Accessory or any other PASCO products, contact PASCO as follows:

Address: PASCO scientific  
10101 Foothills Blvd.  
Roseville, CA 95747-7100

Phone: (916) 786-3800  
FAX: (916) 786-3292  
Web: [www.pasco.com](http://www.pasco.com)  
Email: [techsupp@pasco.com](mailto:techsupp@pasco.com)

## Appendix C: Copyright and Warranty Information

### Copyright Notice

The PASCO scientific 012-08425A *Computer-Based Centripetal Force Accessory Manual* is copyrighted and all rights reserved. However, permission is granted to non-profit educational institutions for reproduction of any part of the 012-08425A *Computer-Based Centripetal Force Accessory Manual*, providing the reproductions are used only for their laboratories and are not sold for profit. Reproduction under any other circumstances, without the written consent of PASCO scientific, is prohibited.

### Limited Warranty

PASCO scientific warrants the product to be free from defects in materials and workmanship for a period of one year from the date of shipment to the customer. PASCO will repair or replace, at its option, any part of the product which is deemed to be defective in material or workmanship. The warranty does not cover damage to the product caused by abuse or improper use. Determination of whether a product failure is the result of a manufacturing defect or improper use by the customer shall be made solely by PASCO scientific. Responsibility for the return of equipment for warranty repair belongs to the customer. Equipment must be properly packed to prevent damage and shipped postage or freight prepaid. (Damage caused by improper packing of the equipment for return shipment will not be covered by the warranty.) Shipping costs for returning the equipment after repair will be paid by PASCO scientific.