

**Instruction Sheet
for the PASCO
Model ME-8750**

HARMONIC OSCILLATOR/DRIVER

Introduction

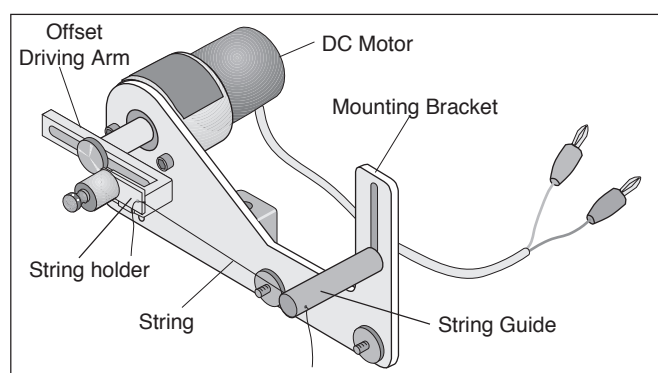

Equipment

The PASCO ME-8750 Harmonic Oscillator/Driver is designed to drive apparatus requiring a low frequency (0.3 to 3 Hz), high torque, sinusoidal oscillation. It consists of a DC motor with an offset driving arm and a mounting bracket. A string can be attached between the driving arm and the apparatus which is to be driven. The Oscillator/Driver will provide a sinusoidal pull on the string. If one desires to both push and pull on an apparatus, the PASCO Push/Pull Accessory (ME-8751) may be added to the Oscillator/Driver.

Features

- 12 VDC motor (frequency: 0.3-3 Hz, current: 0-0.3 A)
- Adjustable Amplitude: adjustable up to 12 cm.
- Photogate Attachment: A photogate can be attached to measure the frequency of the oscillator.
- Driver mounts on Dynamics Track or Rod Stand
- Rubber washers on mounting bracket provide quieter operation on the dynamics track.
- Optional Push/Pull Accessory (ME-8751): Mounts to oscillator, replacing the string and allowing the apparatus to be pushed as well as pulled.

Operation of the Oscillator/Driver

- ① **Mounting:** The Oscillator/Driver can be mounted to a dynamics track to drive dynamics carts or it can be mounted on a rod stand for driving other apparatus. See Figures 1 and 2. Tie one end of a string to the white plastic piece on the driving arm and thread the other end of the string through the hole in the guide. The level of the guide can be adjusted by about 5.5 cm to match the height of the object to be driven.

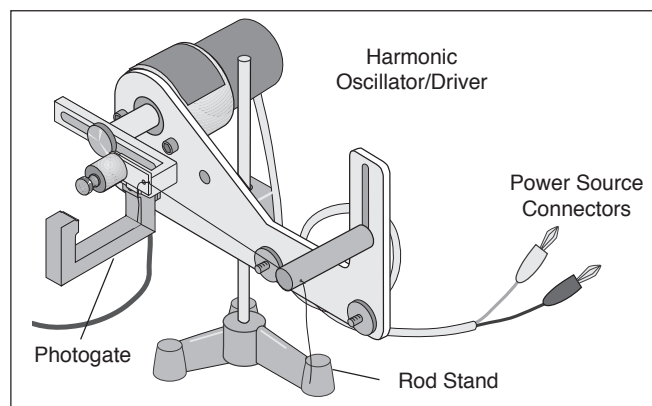

Figure 1: Oscillator/Driver Mounted on a Rod Stand

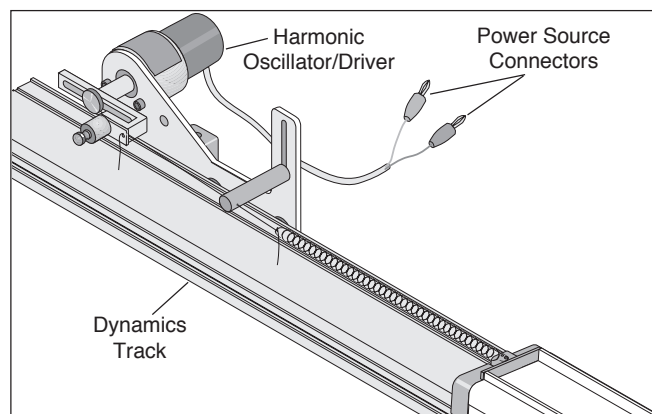

Figure 2: Oscillator/Driver Mounted on Dynamics Track

© 1996 PASCO scientific

This instruction sheet written/edited by: Ann & Jon Hanks

- ② Amplitude Adjustment: To vary the amplitude, loosen the thumb screw that holds the arm to the motor shaft and slide the arm to a new position. Retighten the thumb screw to hold the arm in place. The amplitude is zero when the arm is positioned such that the screw which holds the string holder is aligned over the motor shaft.
- ③ Power Supply: Plug the leads from the Oscillator/Driver into a 12 V (0-0.3 A) variable DC power supply.

► **NOTE:** Do not exceed 12 V.

- ④ Frequency Adjustment: To adjust the frequency, change the voltage of the power supply. An increase in the voltage corresponds to an increase in the frequency.
- ⑤ Measuring the Frequency: Mount a photogate onto the Oscillator/Driver using the slot located below the motor. Each period, the arm will block the photogate. See Figure 1.

Suggested Uses for the Oscillator/Driver

- ① Attach a spring to each end of a dynamics cart. Connect the free end of one spring to the adjustable end stop at one end of the dynamics track. Connect the free end of the second spring to a string tied to the Oscillator/Driver and threaded through the string guide. Drive the spring and cart system at various frequencies to find the resonant frequency of the system.

► **NOTE:** It generally takes the system a little time to respond to a change in frequency of the driving force so some patience is needed to see the resulting change in amplitude.

- ② Use two carts and three springs to find the resonant frequencies of the two different modes of oscillation. See Figure 3.

Other Suggested Uses Requiring Additional Push/Pull Accessory

- ③ Mount the Oscillator/Driver on a rod stand and hang a Longitudinal Wave Spring (WA-9401) from the hook on the Push/Pull accessory. Create a transverse wave in the spring to demonstrate that the wavelength varies down the length of the hanging spring.
- ④ Drive a set of hanging balls (see Figure 4) at various frequencies to show different modes of oscillation and chaotic motion.

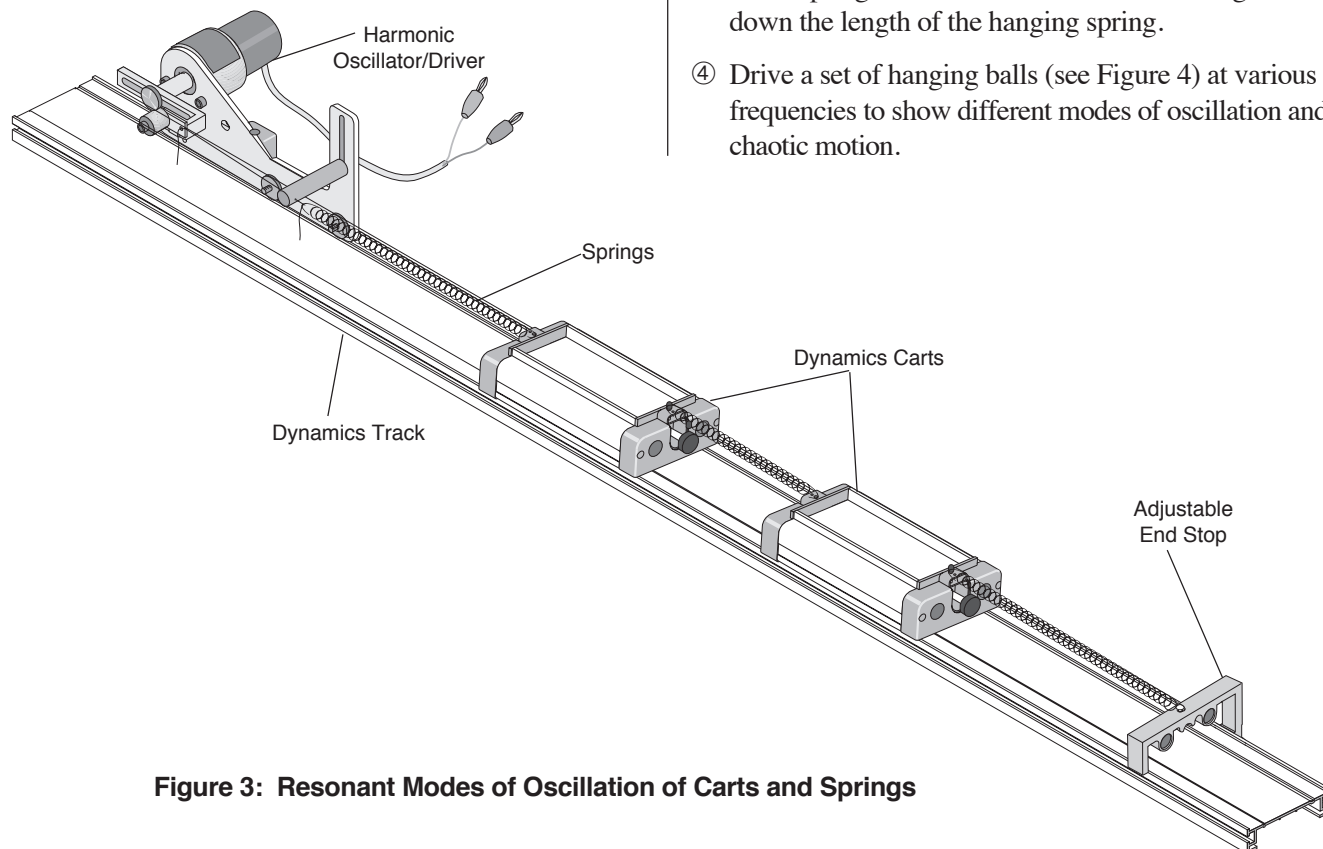

Figure 3: Resonant Modes of Oscillation of Carts and Springs

Limited Warranty

PASCO scientific warrants this product to be free from defects in materials and workmanship for a period of one year from the date of shipment to the customer. PASCO will repair or replace, at its option, any part of the product which is deemed to be defective in material or workmanship. This warranty does not cover damage to the product caused by abuse or improper use. Determination of whether a product failure is the result of a manufacturing

defect or improper use by the customer shall be made solely by PASCO scientific. Responsibility for the return of equipment for warranty repair belongs to the customer. Equipment must be properly packed to prevent damage and shipped postage or freight prepaid. (Damage caused by improper packing of the equipment for return shipment will not be covered by the warranty.) Shipping costs for returning the equipment, after repair, will be paid by PASCO scientific.

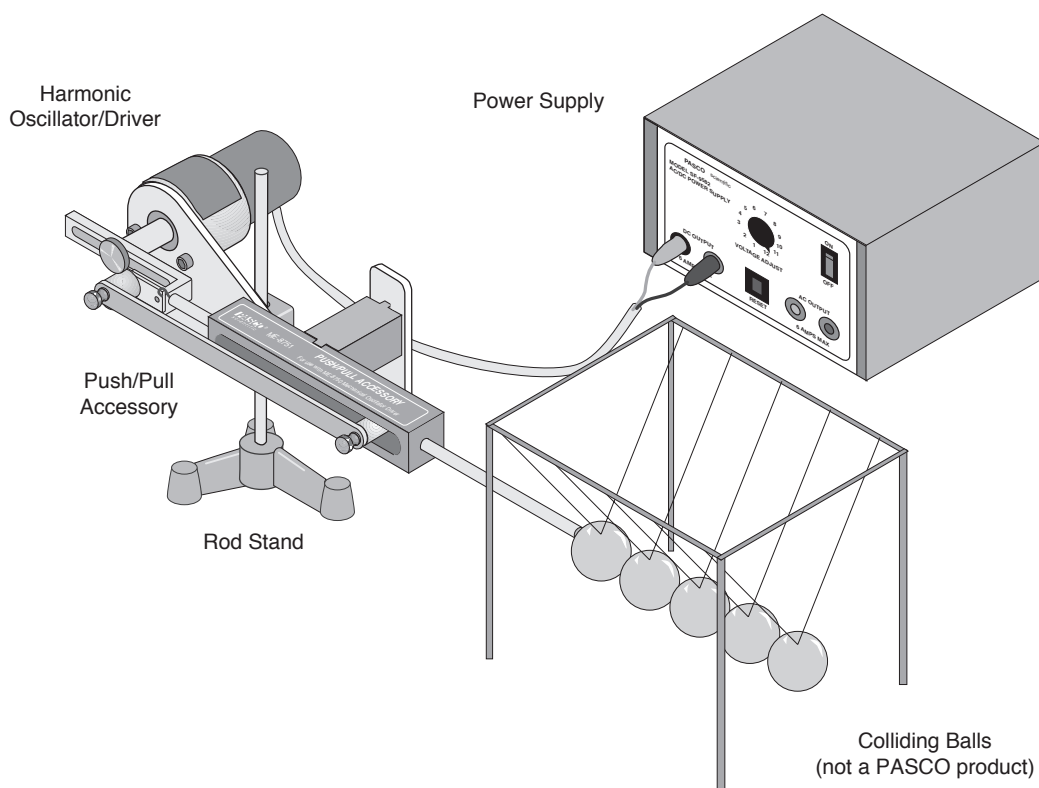

Figure 4: Resonant Modes of Oscillation and Chaotic Motion

Technical Support

Feed-Back

If you have any comments about this product or this manual please let us know. If you have any suggestions on alternate experiments or find a problem in the manual please tell us. PASCO appreciates any customer feedback. Your input helps us evaluate and improve our product.

To Reach PASCO

For Technical Support call us at 1-800-772-8700 (toll-free within the U.S.) or (916) 786-3800.

Internet: techsupp@PASCO.com

Tech Support Fax: (916)786-3292

Contacting Technical Support

Before you call the PASCO Technical Support staff it would be helpful to prepare the following information:

- If your problem is computer/software related, note:

Title and Revision Date of software.

Type of Computer (Make, Model, Speed).

Type of external Cables/Peripherals.

- If your problem is with the PASCO apparatus, note:

Title and Model number (usually listed on the label).

Approximate age of apparatus.

A detailed description of the problem/sequence of events. (In case you can't call PASCO right away, you won't lose valuable data.)

If possible, have the apparatus within reach when calling. This makes descriptions of individual parts much easier.

- If your problem relates to the instruction manual, note:

Part number and Revision (listed by month and year on the front cover).

Have the manual at hand to discuss your questions.