



Ballistic Pendulum Accessory

Model No. ME-9845



Table of Contents

Equipment List	3
Introduction	4
Equipment Setup	4
Taking Measurements and Collecting Data	6
Part I: Measuring the Velocity of the Car	6
Part II: Measuring the Height of the Catcher	8
Experiment	8
Calculations and Analysis	9
Appendix A: DataStudio Setup Instructions	10
Appendix B: Technical Support	11
Appendix C: Copyright and Warranty Information	11

Ballistic Pendulum Accessory

Model No. ME-9845

Equipment List

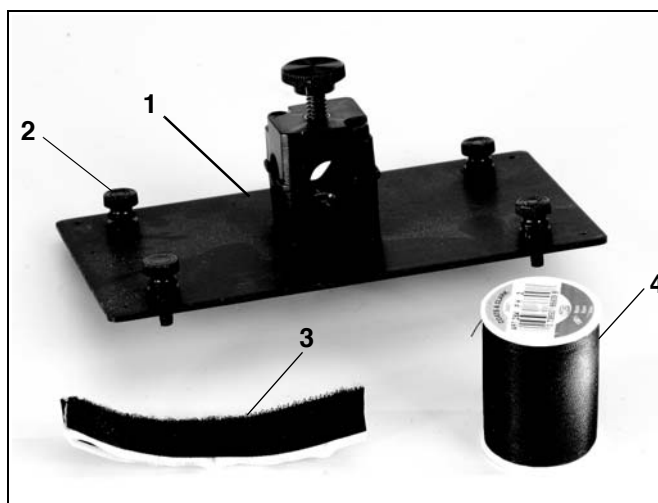

Included Equipment	Replacement Model Number*
1. Support Plate with rod clamp (1)	
2. Thumbscrews, 8-32x1/2 (4)	
3. Thread (1 roll)	
4. VELCRO [®] hook and loop tape**	

* Please contact PASCO Technical Support when no replacement part number is provided.

** **Note:** VELCRO is a registered trademark of Velcro Industries B.V.

Additional Equipment Required	Replacement Model Number
A PASCO computer interface (PASPORT [™] or ScienceWorkshop [®])	Various (See PASCO catalog.)
PASCO Roller Coaster (Complete System)	ME-9812
Photogate and Smart Timer (or computer system with interface)	ME-9498A or ME-8930

Introduction

Using the ME-9845 Ballistic Pendulum Accessory and a PASCO Roller Coaster Set (ME-9812), students can investigate conservation of energy and momentum for a collision.

When the student rolls a Mini-Car from a known height down a Roller Coaster, the car is captured by a catcher (included with the PASCO Roller Coaster Set). The student connects two pieces of thread between a plate (provided with the Ballistic Pendulum Accessory) and the bottom of the catcher. When the car enters the catcher, the catcher swings up.

The kinetic energy of the Mini-Car is transformed into gravitational potential energy as the car/catcher swings to a higher position. The student measures the maximum height of the catcher's swing.

Equipment Setup

1. Assemble the Roller Coaster, so that the track starts at an incline from mid-height (See Figure 1).

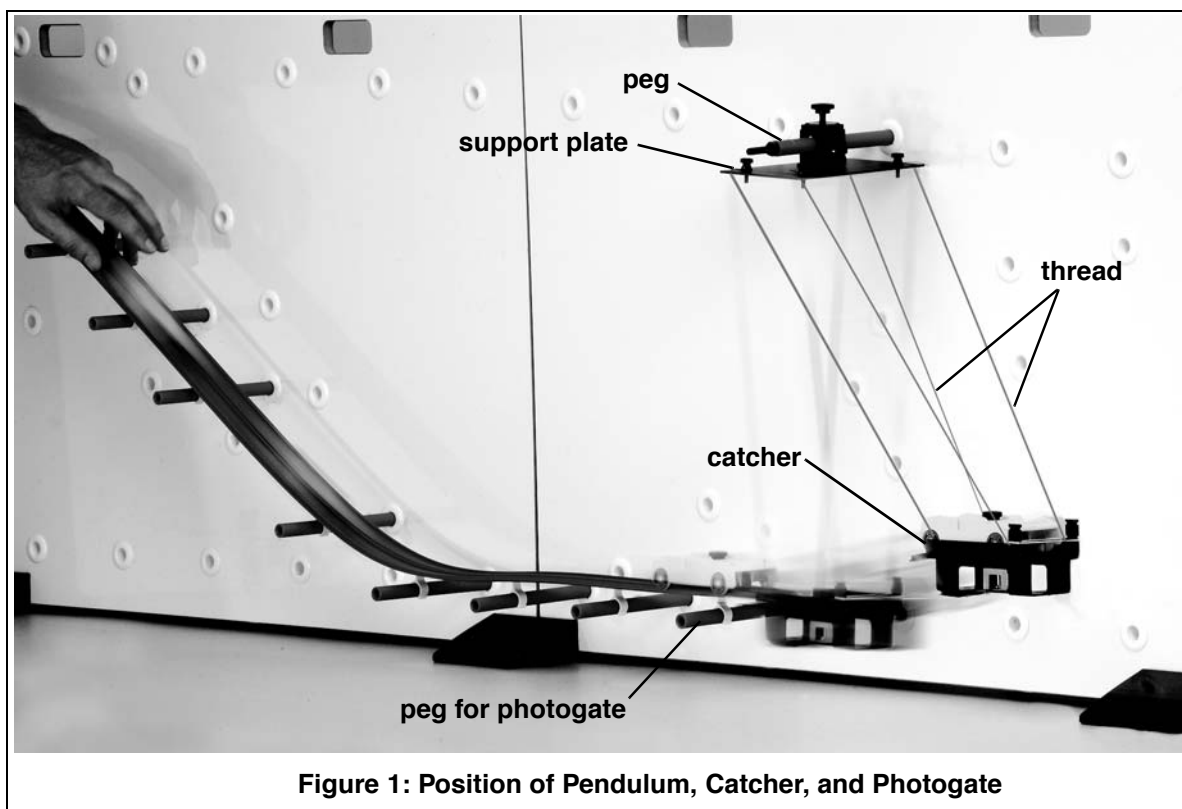

2. Place the photogate support peg on the Roller Coaster. Use the approximate placement hole as shown.

3. Slide the rod clamp of the support plate over the photogate peg and tighten the rod clamp to hold the support plate in place. Keep the long side of the support plate perpendicular to the white board.
4. Adjust the end of the track so that the car goes off the end into the catcher. (For more information, see the Roller Coaster manual provided with the Roller Coaster Set.)
5. Cut two long pieces of thread. Wrap each piece of thread around a thumbscrew on the support plate and thread it through the hole on either side. (For each side, the thread should travel from the hole in the support plate to the outside hole on the catcher, through the inside of the catcher to the other end of the catcher, and return back to the plate.) Adjust the height of the catcher with the thread, making sure that it hangs evenly, and cut off any excess thread. Put the rubber band on the catcher.
6. Cut one 5/8-inch square of the VELCRO hook tape, and two 5/8-inch square pieces of VELCRO loop tape, and place each as shown in Figure 2 on the bottom of the catcher. Cut one 1/34" piece of hook VELCRO and set aside.

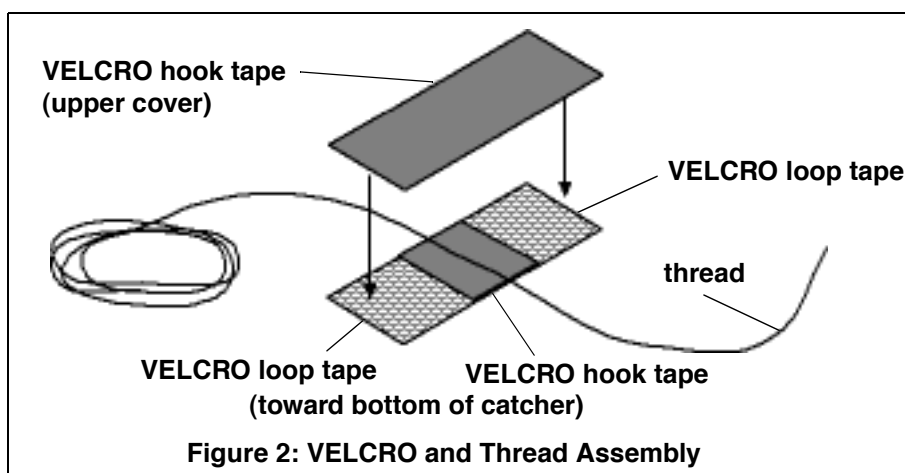

7. With the VELCRO unfastened, run a piece of thread over the center piece of VELCRO hook tape. Fasten the thread in place by placing the reserved piece of VELCRO hook tape on top. Figure 3 shows the VELCRO and thread on the bottom of the catcher.

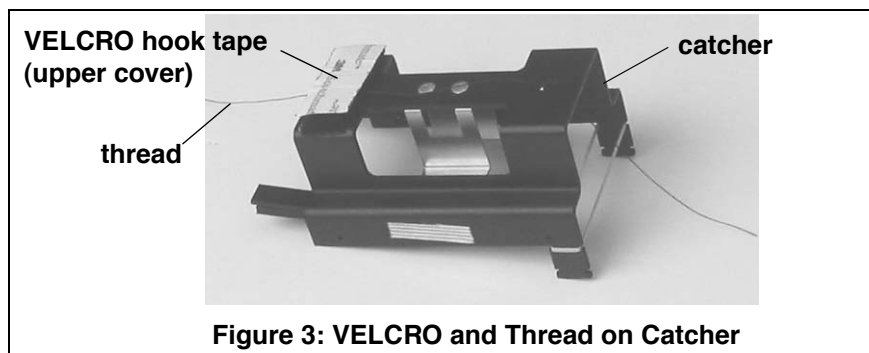

8. Loop the thread to the white track clip on the peg at the end of the track. (See Figure 4.)

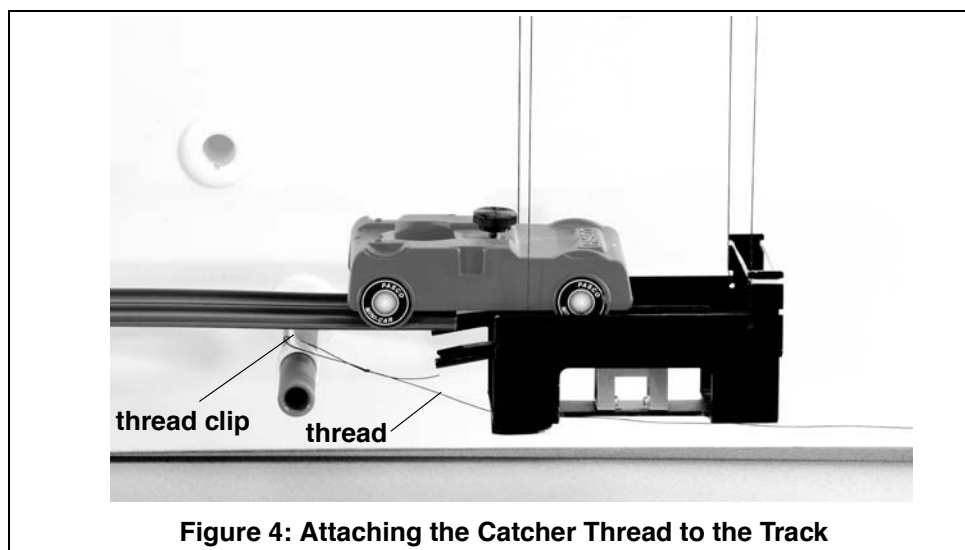

Taking Measurements and Collecting Data

Part I: Measuring the Velocity of the Car:

Option 1: Measuring the Car's Velocity with Photogates and a Computer Interface

1. Place a Photogate on the last peg of the Roller Coaster track. This allows the measurement of the speed of the car just before it runs off the track and into the catcher.
2. Connect the Photogate to a Smart Timer or to a computer interface (*ScienceWorkshop* or PASPORT).
 - a) For the Smart Timer, choose “speed” and “one gate.” The Smart Timer will automatically calculate and display the velocity.

OR

- b) For PASPORT interfaces: Plug the photogate into a PASPORT Photogate Port; then plug the port into the computer interface. Setup your experiment in DataStudio (For instructions, see Appendix A). DataStudio will prompt you for the flag spacing and automatically calculate the velocity.

OR

- c) For *ScienceWorkshop* interfaces: Plug the photogate into a *ScienceWorkshop* interface. Set up your experiment in DataStudio. Use the calculator function to create an equation for the velocity. Enter the spacing on the flag. (See Appendix A for DataStudio setup.)

3. Insert the flag into the car (Figure 5).

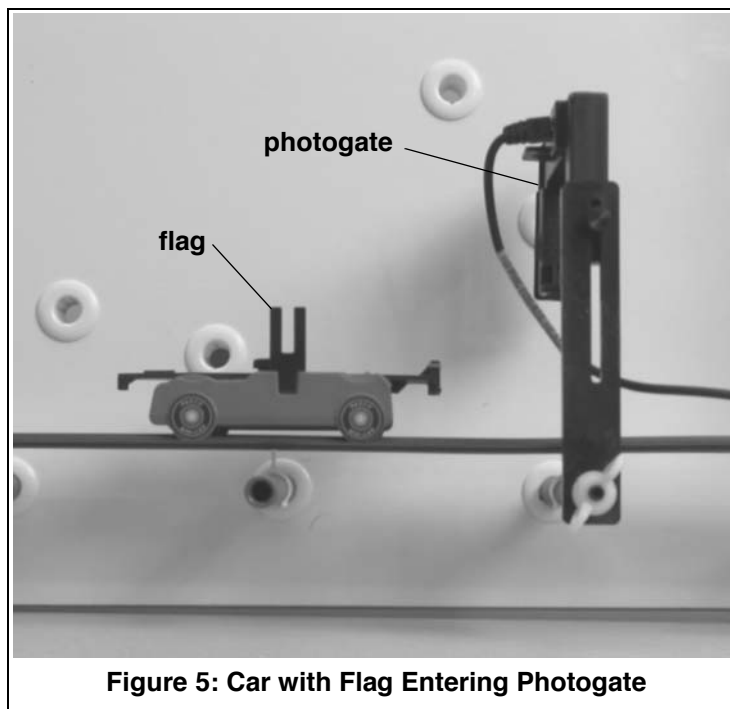

4. Before releasing the car, make sure that when the car passes through the photogate, the flag blocks the photogate beam. If not, adjust the photogate up and down, so that the flag blocks the photogate beam. The nuts on the photogate support peg allow changing of the sideways position of the photogate. (For more information, see the Roller Coaster Manual.) Release the car from the track.

Option 2: Measuring the Speed of the Car without Photogates:

If a photogate is not available, calculate the theoretical speed by measuring the height of the car above the table both at the top and bottom of the hill. Use the following equation to calculate the theoretical speed:

$$mgh = \frac{1}{2}mv^2$$

Note: The speed does not depend on the mass of the car.

Part II: Measuring the Height of the Catcher

1. As the catcher swings up, thread is pulled through the VELCRO strip. When the catcher swings back, the thread stops moving.
2. Hold the thread in place with your thumb and swing the catcher out until the thread is tight.
3. Measure the height of the catcher off the table and subtract the height when the catcher is at the bottom. The difference is the height (**h**) by which the catcher went up.

Experiment

1. Put the car on an incline on the track. Mark the car's starting position on the white board, and release the car from the top of the track.
2. If using photogates, measure the speed of the car. (**Note:** After the first run, do not pull the thread completely back through the VELCRO. Only pull the thread back about 1 cm. This will reduce the amount of VELCRO friction.)
3. For each run, start the car from the same height each time. If using photogates, measure the speed and take an average value for all of the data runs. Measure the height of the catcher for each data run and note the **maximum** height.

Experiment Variations

- a) Repeat this experiment changing the initial speed of the car.
- b) Start the car at a different place on the hill.
- c) Take measurements with different masses in the car (Figure 6).

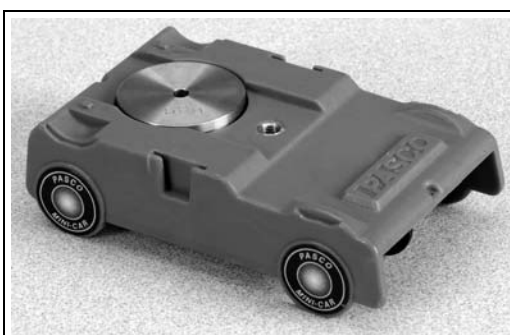

Figure 6: Car with Mass

Calculations and Analysis

m = mass of catcher

m_o = mass of car

v_o = initial speed of car

V = speed of car and catcher immediately after collision (before swinging up)

h = change in height as car and catcher swing up

- Using the measured height h , calculate the speed V of the car and catcher immediately after the collision. During the swing (due to very little friction), one can assume that energy is conserved.

$$(m_o + M)gh = \frac{1}{2}(m_o + M)V^2$$

or

$$V = \sqrt{2gh}$$

During the **collision**, is energy conserved? Compare the kinetic energy before and after the collision.

$$E_{\text{before}} = \frac{1}{2}m_o(v_o)^2$$

$$E_{\text{after}} = \frac{1}{2}(m_o + M)V^2$$

Note that before the collision, only the car (m_o) is moving (v_o) and has kinetic energy. After the collision, both ($m_o + M$) are moving (V) and have kinetic energy.

Because this is a completely inelastic collision, you will find that a large percentage of the kinetic energy disappeared. Calculate the energy ratio ($E_{\text{after}}/E_{\text{before}}$). Where did the rest of the energy go? Heat was generated in the collision.

If the experiment is repeated with a car with a different mass, how does the energy ratio ($E_{\text{after}}/E_{\text{before}}$) change?

- During the collision, is momentum conserved? Compare the momentum before and after the collision.

$$(\text{Momentum})_{\text{before}} = m_o(v_o)$$

$$(\text{Momentum})_{\text{after}} = (m_o + M)V$$

The momentums should be very similar, and in theory the same. However, you may not observe the momentums to be exactly equal. In theory, energy is "lost" in an inelastic collision, but the momentum of the system remains the same.

Appendix A: DataStudio Setup Instructions

Procedure	Steps
<p>PART I: Plug the photogate into the interface:</p>	<p>PASPORT: a) Plug a Photogate into either port of a PASPORT Photogate Port. b) Plug the Photogate Port into a PASPORT interface. c) Connect the PASPORT interface (i.e. USB Link, PowerLink, etc.) to a USB port on your USB-compatible computer. d) When the PASPORTAL window opens, select “Launch DataStudio.” OR ScienceWorkshop: a) Plug the stereo plug on the Photogate into a <i>ScienceWorkshop</i> interface. b) Launch DataStudio.</p>
<p>PART II: Set up your experiment</p>	<p>PASPORT: a) In the PASPORT Setup window, click on the Add Timer button and select Photogate Timing from the available choices. b) At the prompt, enter the flag length and photogate spacing and click OK. c) In the PASPORT Setup window, scroll to the Photogate Timing box, and select “time in gate” and “velocity in gate.” OR ScienceWorkshop: a) In the Welcome to DataStudio window, double click “Create Experiment.” b) In the Sensors list, click and drag a Photogate icon to the picture of the interface (i.e. to the same digital channel in which you have the photogate connected.) c) In the Experiment Setup window, double click on the Photogate icon. d) In the Measurement tab, select “time in gate” and “velocity in gate.” e) In the Constant tab, enter the flag length in meters and click OK. f) In the main toolbar, click the Timers button. g) Under Label, type a name for your timing sequence. h) Click on the down arrow next to channel 1 and select “blocked.” i) Click on the arrow again and select “unblocked.” j) Click the Done button to save your timing scheme.</p>
<p>PART III: Create the velocity equation (for <i>ScienceWorkshop</i> interfaces)</p>	<p>a) Click the New button to create a new equation. In the equation box, type in the velocity equation: $v=d/t$, where v= velocity in m/s, d=distance in meters, and t=time in seconds. Click the Accept button. b) Under Variables, next to variable “d”, click on the down arrow, select constant, and type in the flag distance from leading edge to leading edge (about .001 m). c) For variable “t”, click on the down arrow, select “data measurement,” “time in gate” and click OK. (For more instructions on building equations, see the DataStudio online help.)]</p>
<p>PART IV: Collect Data</p>	<p>a) From the Data list, drag the velocity equation over a y-axis in a separate Table display. b) Click the Start button on the main toolbar.</p>

Appendix B: Technical Support

For assistance with the ME-9845 or any other PASCO products, contact PASCO as follows:

Address: PASCO scientific

10101 Foothills Blvd.

Roseville, CA 95747-7100

Phone: (916) 786-3800

FAX: (916) 786-3292

Web: www.pasco.com

Email: techsupp@pasco.com

Appendix C: Copyright and Warranty Information

Copyright Notice

The PASCO scientific 012-08820A *Ballistic Pendulum Accessory Manual* is copyrighted and all rights reserved. However, permission is granted to non-profit educational institutions for reproduction of any part of the 012-08820A *Ballistic Pendulum Accessory Manual*, providing the reproductions are used only for their laboratories and are not sold for profit. Reproduction under any other circumstances, without the written consent of PASCO scientific, is prohibited.

Limited Warranty

For a description of the product warranty, see the PASCO catalog.