



Physical Pendulum Accessory

Model No. ME-9858

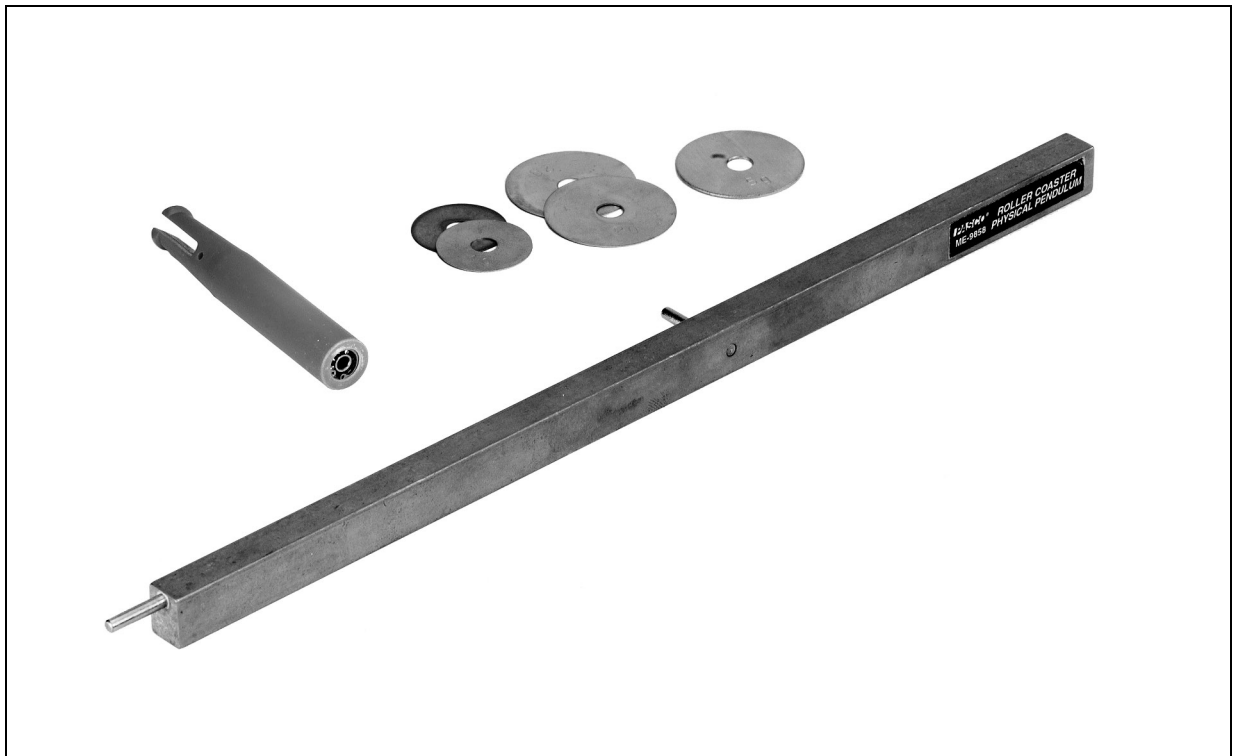

Table of Contents

Equipment List	3
Introduction	4
Equipment Setup	4-5
Taking Measurements and Collecting Data	6
Part I: Measure and Adjust the Mass of the Car	6
Part II: Record the Pendulum's Mass, Length, and Radius	6
Part III: Collecting Velocity Data	7
Option 1: Measuring the Car's Velocity with Photogates and a Computer Interface	7
Option 2: Measuring the Car's Velocity without a Photogate	7
Theory	8-9
Experiment	9
Calculations	10-11
Appendix A: DataStudio Setup Instructions	11
Appendix B: Technical Support	12
Appendix C: Copyright and Warranty Information	12

Physical Pendulum Accessory

Model No. ME-9858

Equipment List

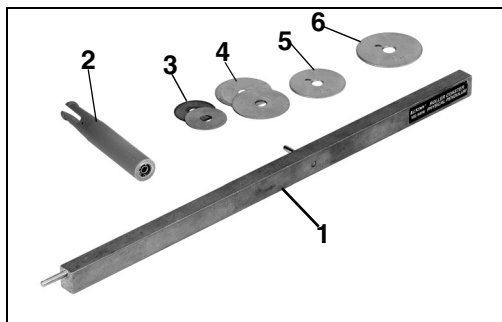

Included Equipment	Replacement Model Number*
1. Pendulum rod with pivot pin (1)	003-08577
2. Pivot Rod with Ball Bearings (1)	616-101
3. Mass, 1 gram (2)	648-06505
4. Mass, 2 grams (2)	648-06506
5. Mass, 5 grams (1)	648-06507
6. Mass, 10 grams (1)	648-06508

*Use Replacement Model Numbers to expedite replacement orders.

Additional Equipment Required	Replacement Model Number*
A PASCO computer interface (PASPORT™ or ScienceWorkshop®)	Various (See PASCO catalog.)
Roller Coaster	ME-9812
Photogate and Smart Timer or computer system with interface	ME-8930 and ME-9498A

Introduction

The Physical Pendulum Accessory (ME-9858) is used with the PASCO Roller Coaster (ME-9812). The Mini-Car provided with the Roller Coaster Apparatus has a rubber band bumper, which collides elastically with the Physical Pendulum Accessory. The Physical Pendulum Accessory attaches to a PASCO Roller Coaster. The collision allows detailed studies of angular momentum, linear and rotational kinetic energy, and gravitational potential energy. The release point of the Mini-Car can be adjusted until the pendulum just makes it to the top of its 180-degree rotation.

A detailed theoretical explanation is provided in Appendix A of this manual.

Setup

1. a) Assemble the track to start on the left board at the middle height position (Figure 1). The track should extend past the edge of the board on the right.
- b) You can place a catcher at the end of the track as a back-up, but it is not usually needed.

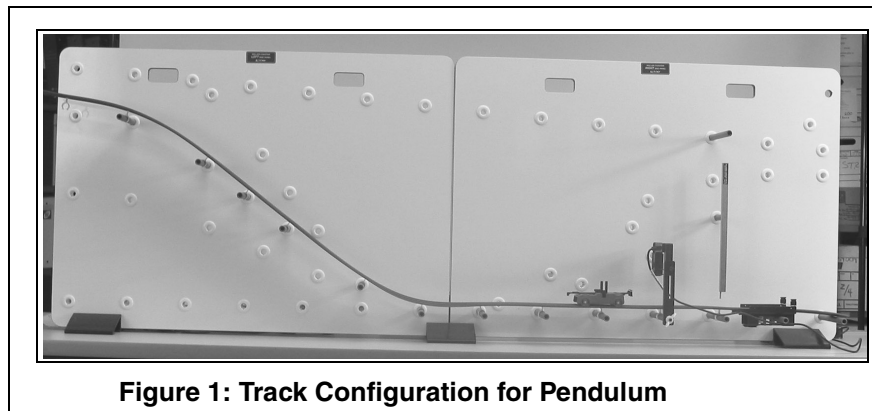

2. a) Attach the pendulum bar by sliding the pivot pin into the middle of the pendulum bearings. Insert the pivot rod into the exact hole shown on the peg board (Figure 2a).

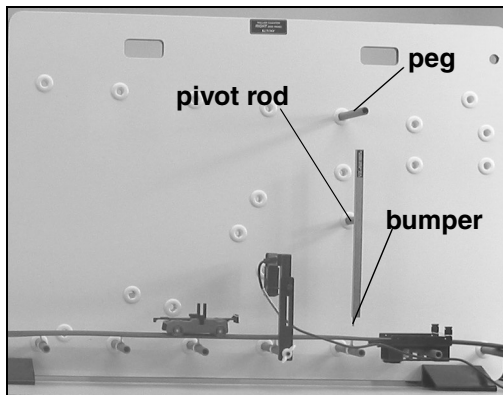

Figure 2a: Front view of pendulum with pivot pin

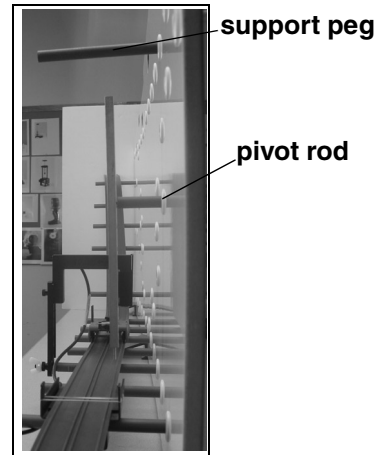

Figure 2b: Side view of pendulum with pivot pin

- b) Place a normal length support peg in the hole as shown at the top of the swing (Figure 2a). This acts as a stop to prevent the pendulum rotating more than 180° .

- 3.a) Put the bumper on the car, as shown in Figure 3a. Use two rubber bands. b) Release the car "backwards" with the rubber band part of the bumper in front.

Note: The bumper pin on the end of the pendulum must hit the middle of the rubber band (Figure 3b). Adjust the position of the track side to side to achieve the correct position. If the bumper is not the correct height to hit the pin, you have the pivot support rod in the wrong hole.

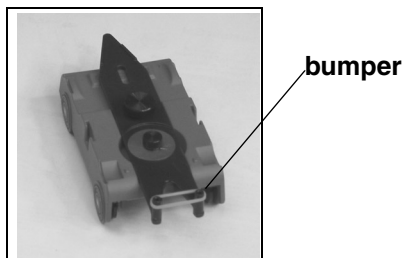

Figure 3a: Bumper on Car

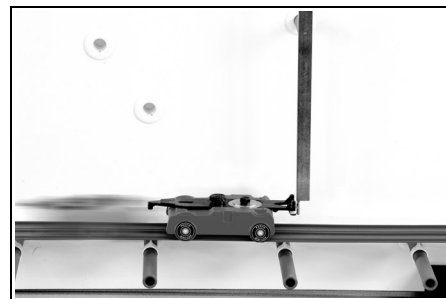

Figure 3b: Bumper against Pin on Pendulum

Taking Measurements and Collecting Data

Part I: Measure and Adjust the Mass of the Car

1. Release the car from halfway up the hill and carefully watch the collision. If the car has no added masses, it will rebound off of the pendulum, and thus be moving "backwards" after the collision. If the ballast mass was added, the car would continue in the forward direction after the collision. (Here is a good reason to use the catcher at the end of the track as a safety stop.)



CAUTION: Catch the pendulum before it swings back down! Don't let it swing down and hit the car!

2. With the small screw provided with the car, secure the small masses in the tray on top of the bumper (Figure 4.)
3. Using the small masses provided, adjust the mass of the car so that after the collision, the car is neither moving forwards or backwards. The car should stop completely, so that its velocity after the collision is zero. The mass needed to do this is independent of the speed of the car, but if the car is moving too slowly, friction will stop the car any way. Start the car at least half way up the hill during this part of the experiment.

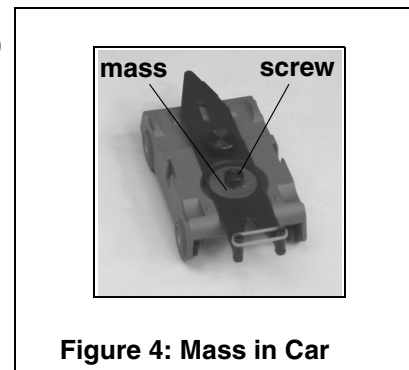

Figure 4: Mass in Car

4. After adding the proper amount of mass, weigh the mass of the entire car (m_0).

Part II: Record the Pendulum's Mass, Length, and Radius

1. Find the pendulum's mass (M). (Note: This does **not** include the pivot support rod.)
2. Measure the length (ℓ) of the brass part of the pendulum. Do **not** include the bumper pin.
3. Measure the distance (d) from the center of the pivot pin to the top end of the pendulum (the non-pin end) (See Figure 5).
4. With the pendulum on the support pivot, and the car's bumper against bumper pin, measure the distance (r) from the center pivot pin out to the position of the rubber bands on the car bumper. This is the radius at which the car applies a force (and thus a torque) to the pendulum, causing it to rotate. Note: Because of the bumper pin, $\ell \approx d+r$.

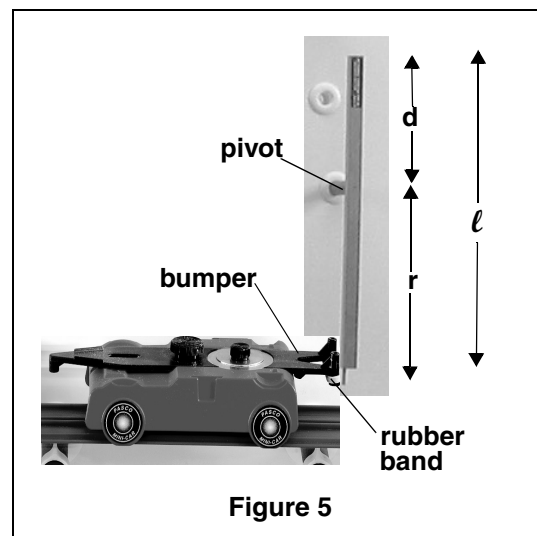

Figure 5

Part III: Collecting Velocity Data

Option 1: Measuring the Car's Velocity with Photogates and a Computer Interface

1. Place a Photogate on the last peg of the Roller Coaster track. This will allow you to measure the speed of the car just before it hits the pendulum (Figure 6).
2. Connect the Photogate to a Smart Timer or to a computer interface (*ScienceWorkshop* or PASPORT).

Note: If you are using a PASPORT interface, first plug the photogate into a PASPORT Photogate Port; then plug the port into the computer interface.

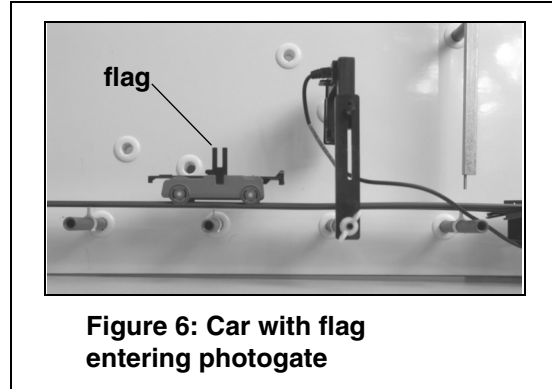

3. Insert the flag into the car (Figure 6). When the car passes through the photogate, the flag must block the photogate beam. If not, adjust the photogate up and down, so that the flag blocks the photogate beam. The nuts on the photogate support peg allow the sideways position of the photogate to also be changed. (For more information, see the Roller Coaster Manual).
4. For the Smart Timer, choose speed, one gate, and the velocity will be calculated and displayed. To use a computer, you will have to use the calculator function and the spacing on the flag (For instructions, see Appendix A in this manual).

Option 2: Measuring the Car's Velocity without a Photogate

If you do not have a photogate available, you can estimate the car's speed using conservation of energy. By measuring the height of the car above the table both at the top of the hill and at the bottom, the theoretical speed can be calculated, as follows:

$$mgh = \frac{1}{2}mv^2$$

Note: The theoretical speed does not depend on the mass of the car.

Theory

m_o = mass of car (including bumper and masses)

M = mass of pendulum

v_o = speed of the car just before collision

ℓ = length of physical pendulum (ignoring bumper pin)

x = distance from center of mass (c.m.) to pivot (calculated)

d = distance from pivot to (non-bumper) end of pendulum (directly measured by student)

r = distance from pivot to rubber band on bumper (directly measured by student)

I = rotational inertia of pendulum about pivot (calculated)

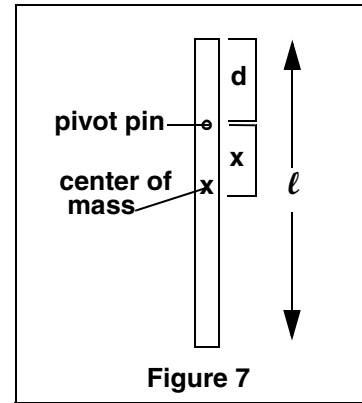

1. Center of Mass

The center of mass of the physical pendulum can experimentally be found by balancing it on a knife's edge, but since the pins have negligible mass, you can assume its center of mass is at the center ($\ell/2$). Thus the distance, x (Figure 7), the distance from the center of mass to the pivot point is $x = \frac{1}{2}\ell - d$ (1).

2. Rotational Inertia

The rotational inertia of a thin rod (total length ℓ) about its center of mass is

$$I_{cm} = \frac{1}{12}M\ell^2 \quad (2).$$

If the axis of rotation is not about the center of mass, but is instead about a parallel axis a distance x from the center of mass, the Parallel Axis Theorem states that the new rotational inertia is

$$I = I_{cm} + Mx^2 \quad (3).$$

Thus, combining these two gives the rotational inertia of the physical pendulum as

$$I = \frac{1}{12}M\ell^2 + Mx^2 \quad (4).$$

3. Angular Momentum

The linear momentum (p) of the car is $m_o v_o$, but in a collision that causes rotation, we have to look at the angular momentum $\vec{L} = \vec{r} \times \vec{p}$, where r is the distance from the car (rubber band) up to the pivot, and the magnitude of the initial angular momentum of the car about the pivot is

$$L_o = m_o v_o r \quad (5).$$

After the collision, the car is stopped, and the pendulum is rotating with some initial angular speed ω . The pendulum has angular momentum

$$L = I\omega \quad (6).$$

4. Kinetic Energy

The initial kinetic energy (KE_o) of the car is

$$KE_o = \frac{1}{2} m_o v_o^2 \quad (7).$$

After the collision, the car is stopped, and the pendulum is rotating with some initial angular speed ω . The pendulum rotational kinetic energy is

$$KE = \frac{1}{2} I\omega^2 \quad (8).$$

5. Potential Energy

When a point mass increases its height by an amount h , it increases its gravitational potential energy (PE) by an amount mgh . For a non-point mass like the physical pendulum, the distance h is the amount the center of mass moves upward.

For a complete 180° rotation (Figure 8), that distance $h=2x$, and thus the gain in potential energy is

$$PE = 2Mgx \quad (9).$$

Experiment

1. Adjusting the release height on the track.

Release the car from half the way up the hill, so that the pendulum does **not** hit the top support peg. Repeat, releasing the car from a higher elevation each time, until the pendulum "just" makes it to the top. You will need to use the marker on the white board to keep track of your position. If you do it just right, you can get the pendulum to stop upside down. If the pendulum hits the top peg and bounces off, your release point was too high.

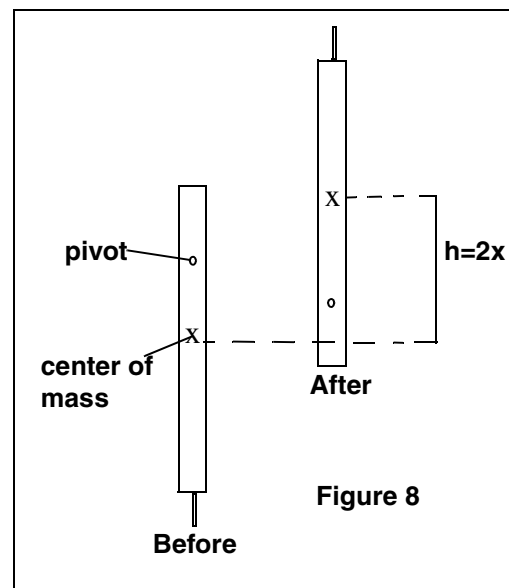

Figure 8

Also, recheck what the car does after the collision. If the car is moving at all, you don't have the mass correct; go back and adjust the mass.

2. Measure the speed of the car.

If using photogates, start measuring the speed for each trial, so that when you do get the pendulum to stop at the top, you can use the value as the speed (v_o) of the car. Otherwise, calculate the theoretical speed using the change in height.

Calculations

1. Using equation (1), calculate the distance $x = \frac{1}{2} \ell - d$.

2. Calculate the rotational inertia of the pendulum (I) using equation #4.

3. Initial angular speed (ω) of the pendulum:

Because there is very little friction, we can assume conservation of energy as the pendulum swings up to its stopped position at the top. Thus, the pendulum's total energy at the bottom (only rotational KE) is equal to its total energy at the top (only PE).

Using equations #8 and #9, $\frac{1}{2} I \omega^2 = 2Mgx$ and solving for the angular speed,

$$\omega = \sqrt{\frac{4Mgx}{I}}$$

Using your values, calculate the initial angular speed, ω .

4. Angular momentum before and after the collision

Using equation #5, calculate the angular momentum before the collision.

$$\mathbf{L}_o = \mathbf{m}_o \mathbf{v}_o \mathbf{r}$$

Using equation #6, calculate the resulting angular momentum of the pendulum.

$$\mathbf{L} = I\omega$$

How do these two values compare? Calculate the percent difference between them. What are the sources of error? Did the momentum of the system really change?

5. Kinetic energy before and after the collision:

Using equation #7, calculate the initial KE_o of the car.

$$KE_o = \frac{1}{2} m_o v_o^2$$

Using equation #8, calculate the resulting KE of the pendulum.

$$KE = \frac{1}{2}I\omega^2$$

How do these two values compare? Calculate the percent difference between them. How "elastic" was the rubber band collision? What are the sources of error? Did you lose or gain energy? What would you expect? Explain why.

Appendix A: DataStudio Setup Instructions

Procedure	Steps
PART I: Plug the photogate into the interface:	<p>PASPORT: a) Plug the Photogate Port into either port on a PASPORT Photogate Port. b) Plug the Photogate Port into a PASPORT interface. c) Connect the PASPORT interface (i.e. USB Link, PowerLink, etc.) to a USB port on your USB-compatible computer. d) When the PASPORTAL window opens, select "Launch DataStudio."</p> <p>OR</p> <p>ScienceWorkshop: a) Plug the stereo plug on the Photogate into a <i>ScienceWorkshop</i> interface. b) Launch DataStudio.</p>
PART II: Set up your experiment	<p>PASPORT: a) In the PASPORT Setup window, click on the Add Timer button and select Photogate Timing from the available choices. b) At the prompt, enter the flag length and photogate spacing and click OK. c) In the PASPORT Setup window, scroll to the Photogate Timing box, and select "time in gate" and "velocity in gate."</p> <p>OR</p> <p>ScienceWorkshop: a) In the Welcome to DataStudio window, double click "Create Experiment." b) In the Sensors list, click and drag a Photogate icon to the picture of the interface (i.e. to the same digital channel in which you have the photogate connected.) c) In the Experiment Setup window, double click on the Photogate icon. d) In the Measurement tab, select "time in gate" and "velocity in gate." e) In the Constant tab, enter the flag length in meters and click OK. f) In the main toolbar, click the Timers button. g) Under Label, type a name for your timing sequence. h) Click on the down arrow next to channel 1 and select "blocked." i) Click on the arrow again and select "unblocked." j) Click the Done button to save your timing scheme.</p>
PART III: Create the velocity equation	<p>a) Click the New button to create a new equation. In the equation box, type in the velocity equation: $v=d/t$, where v= velocity in m/s, d=distance in meters, and t=time in seconds. Click the Accept button. b) Under Variables, next to variable "d", click on the down arrow, select constant, and type in the flag distance from leading edge to leading edge (about .001 m). c) For variable "t", click on the down arrow, select "data measurement," "time in gate" and click OK. (For more instructions on building equations, see the DataStudio online help.)]</p>
PART IV: Collect Data	<p>a) From the Data list, drag the velocity equation over a y-axis in a separate Table display. b) Click the Start button on the main toolbar.</p>

Appendix B: Technical Support

For assistance with the ME-9858 or any other PASCO products, contact PASCO as follows:

Address: PASCO scientific

10101 Foothills Blvd.

Roseville, CA 95747-7100

Phone: (916) 786-3800

FAX: (916) 786-3292

Web: www.pasco.com

Email: techsupp@pasco.com

Appendix C: Copyright Notice and Warranty Information

Copyright Notice

The PASCO scientific 012-08581A *Physical Pendulum Accessory Manual* is copyrighted and all rights reserved. However, permission is granted to non-profit educational institutions for reproduction of any part of the 012-08581A *Physical Pendulum Accessory Manual*, providing the reproductions are used only for their laboratories and are not sold for profit. Reproduction under any other circumstances, without the written consent of PASCO scientific, is prohibited.

Warranty Information

For information about the product warranty, see the PASCO catalog.