

Human Eye Model

OS-8477



Contents

Introduction	1
Maintenance and Storage	3
Specifications.	4
Background	5
Experiment Setup	11
Experiment 1: Optics of the Human Eye	13
Experiment 2: Telescope	25
Experiment 3: Refraction, a Detailed Study.	29
Other Suggested Activities.	33
Teachers' Notes.	35
Technical Support	39

Human Eye Model

OS-8477

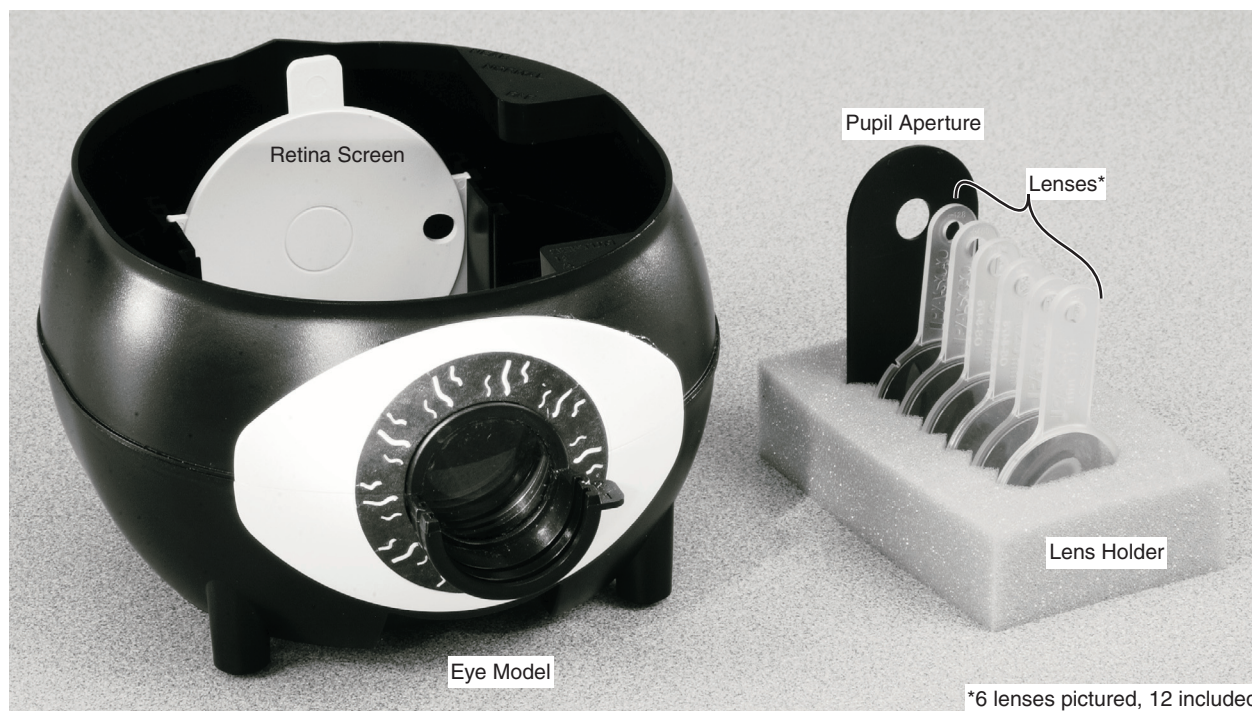

Included Equipment	Part Number
Eye Model	OS-8477
Lens Set:	OS-8476
12 Lenses	
1 Retina Screen	
1 Pupil Aperture	
1 Foam Lens Holder	

The PASCO Human Eye Model consists of a sealed plastic tank shaped roughly like a horizontal cross section of an eyeball. A permanently mounted, plano-convex, glass lens on the front of the eye model acts as the cornea. The tank is filled with water, which models the aqueous and vitreous humors. The crystalline lens of the eye is modeled by a changeable lens behind the corneal. A movable screen at the back of the model represents the retina.

Lenses

The components of the eye model are equipped with handles, which allow them to be easily inserted into the water. The handles of the plastic lenses are marked with their focal lengths *in air*. Two of the lenses are cylindrical lenses for causing and correcting astigmatism in the model; these can be identified by notches on their edges that mark the cylindrical axes. (See page 4 for complete lens specifications.)

Lens Positions

The crystalline lens, which is supported in the slot labeled SEPTUM, can be replaced with different lenses to accommodate, or focus, the eye model at different distances. (The label refers to the septum, or partition, formed by the lens and other tissues that separates the aqueous and vitreous humors.) Two other slots behind the cornea, labeled A and B, can hold additional lenses to simulate changing the power of the crystalline lens.

A cylindrical lens can be placed in slot A or B to give the eye astigmatism. The pupil aperture can also be placed into slot A or B to demonstrate the effect of a round or “cat-shaped” pupil.

Two slots in front of the cornea, labeled 1 and 2, can hold simulated eyeglasses lenses to correct for near-sightedness, far-sightedness, and astigmatism.

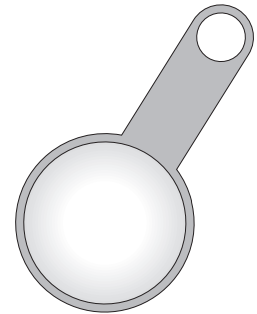

Spherical Lens



Cylindrical Lens

Retina

A circle marked on the retina screen represents the fovea, and a hole in the screen represents the blind spot. The retina screen can be placed in three different positions (labeled NORMAL, NEAR, and FAR) to simulate a normal, near-sighted, or far-sighted eye.

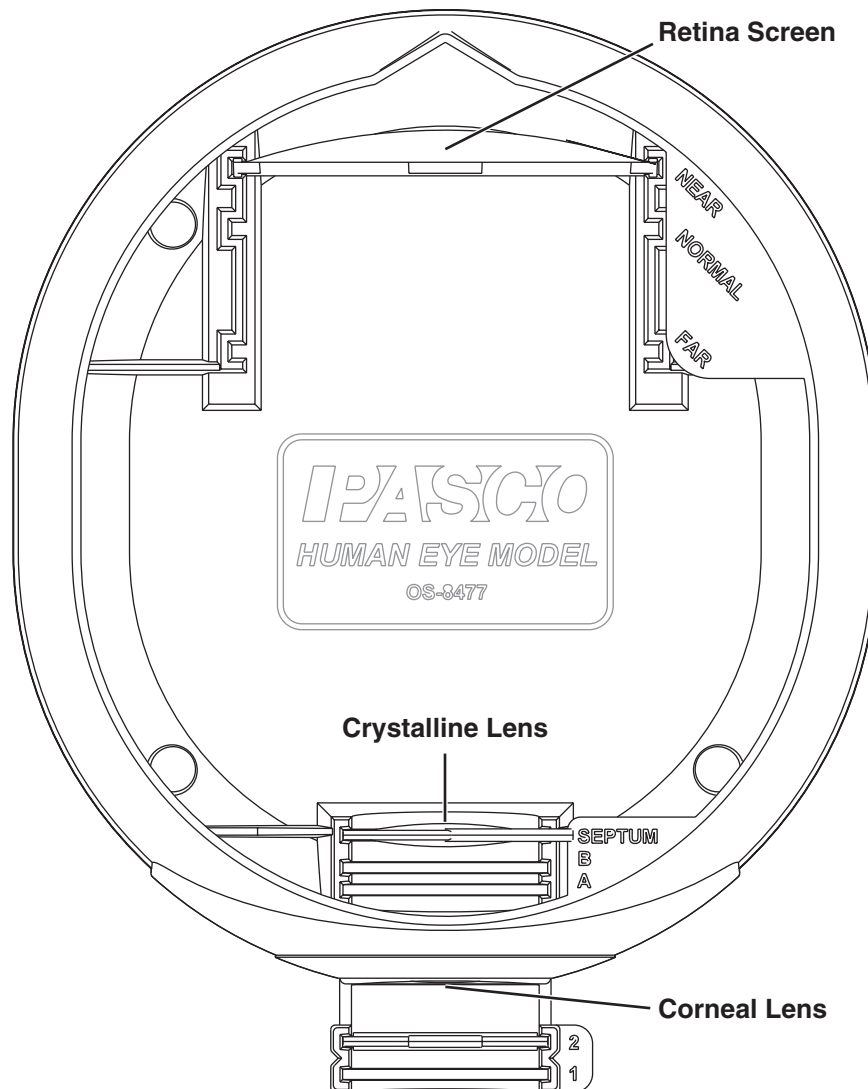

Demonstration Without Water

The eye model can be used with or without water. With no water, and no changeable lenses in place (using only the corneal lens), the eye model focuses at optical infinity. Set the eye model to look out a window to see a large, full-color image of “outside” on the retina screen.

Maintenance and Storage

The eye model includes two each of 6 different lenses. Put six of them aside as replacements for lost or damaged lenses; put the other six in the included foam holder along with the pupil aperture. The lenses are made of polycarbonate plastic, which has a high index of refraction but scratches easily. Do not wipe or rub the lenses; let them air dry on a paper towel or in the foam holder. The glass corneal lens can be cleaned or dried with a soft cloth.

Allow the eye model and its components to dry completely before storing them in a closed space. When they are dry, place the lenses and lens holder inside the eye model for storage.

For a set of replacement parts, order PASCO model number OS-8476, which includes a retina screen, a pupil aperture, two of each lens, and a lens holder.

Specifications

Model Eye

Dimensions	15 cm × 17 cm × 10 cm
Water Capacity	1 liter
Retina Diameter	7 cm

Movable Lenses

Material	Polycarbonate Plastic
Diameter	3 cm

Focal Lengths (In Air)

Spherical Convergent	+120 mm
Spherical Convergent	+62 mm
Spherical Convergent	+400 mm
Spherical Divergent	-1000 mm
Cylindrical Convergent	+307 mm
Cylindrical Divergent	-128 mm

Index of Refraction (Polycarbonate Plastic)

Color	Wavelength	Index of Refraction
Blue	486 nm	1.593
Yellow	589 nm	1.586
Red	651 nm	1.576

Plano-convex Corneal Lens

Material	B270 Glass
Diameter	3 cm
Thickness	4 mm
Radius of Curvature	71 mm
Focal Length (in air)	140 mm

Index of Refraction (Glass)

Color	Wavelength	Index of Refraction
Blue	486 nm	1.529
Green	546 nm	1.525
Yellow	589 nm	1.523
Red	656 nm	1.520

Background

How Lenses Form Images

Light rays are bent, or refracted, when they cross an interface between two materials that have different indices of refraction. The **index of refraction** of a material is the ratio of the speed of light in a vacuum to the speed of light in the medium. Light passing through a lens crosses two such interfaces: one where it enters the lens at the front surface, and another where it leaves the lens at the back surface.

Lenses and Focal Length

The amount by which light is bent is quantified by the lens's **focal length**. A strong lens, which can bend rays so that they intersect at a short distance, is said to have a short focal length. A weaker lens bends rays less, so that they intersect further away, and is said to have a long focal length. If the incoming rays are *parallel*, the distance at which the outgoing rays intersect is equal to the lens's focal length.

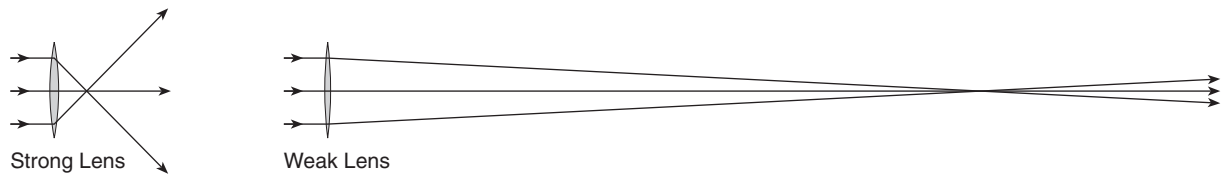

The focal length of a lens is determined by the curvatures of its front and back surfaces, its index of refraction, and the index of refraction of the material surrounding the lens. A lens with highly curved surfaces usually has a shorter focal length than one with flatter surfaces made from the same material. A lens with a high index of refraction has a shorter focal length than an identically shaped lens with a low index of refraction. A lens surrounded by air (which has a low index of refraction) has *lower* focal length than the same lens immersed in water (which has a high index of refraction).

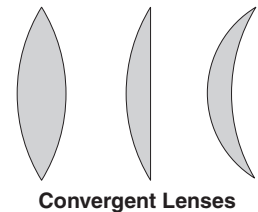

Convergent Lenses

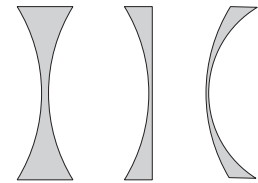

Divergent Lenses

There are two types of lenses: convergent and divergent. A **convergent lens** makes incoming parallel rays converge, or come together. A convergent lens typically has a convex surface and is thicker at the center than at the edge. The focal length of a convergent lens is positive. A **divergent lens** makes incoming parallel rays diverge, or spread apart. A divergent lens typically has a concave surface and is thinner at the center than at the edge. The focal length of a divergent lens is negative.



Images and Image Distance

When an object is placed in front of a lens, the light from the object passing through the lens forms an image. There are two types of images: real and virtual. A **real image** is formed by converging rays at the point where they intersect. A real image can be viewed on a screen placed at that point, and you can see it directly if you place your eye behind that point. A **virtual image** is formed by diverging rays at the point where imaginary lines drawn through the rays intersect. If you allow these diverging rays to enter your eye, you will see the virtual image located at the point where the rays appear to be coming from.

The distance from the lens to the image is called the **image distance**. A real image is formed behind the lens and has a *positive* image distance. A virtual image is formed in front of the lens and has a *negative* image distance.

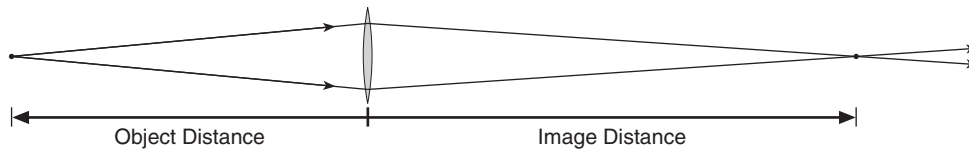
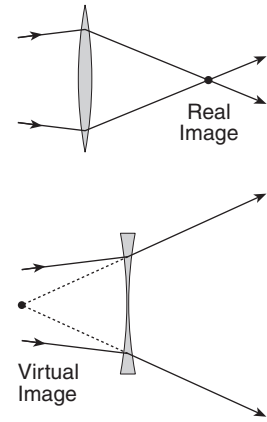

Objects and Object Distance

Lenses focus light from an **object**. The distance from the lens to the object is called the **object distance**. In a single-lens system, the object is placed in front of the lens and the object distance is positive.

In a two-lens system, the object focused on by the second lens is the image (either real or virtual) formed by the first lens. If this object is in front of the second lens, the object distance is positive. If the object is behind the lens, the object distance is *negative*.

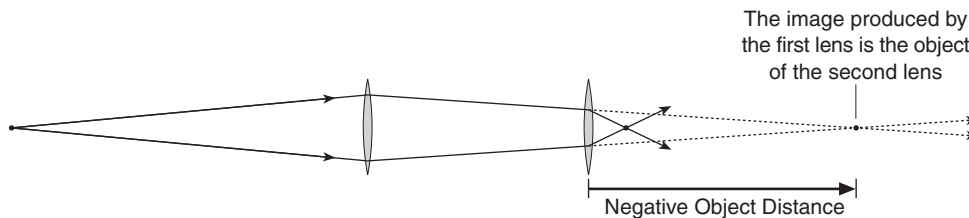

Thin Lens Formula

The focal length of a lens (f) is related to object distance (o) and the image distance (i) by the **Thin Lens Formula**:

(eq. 1)
$$\frac{1}{f} = \frac{1}{i} + \frac{1}{o}$$

If the object is very far from the lens, the object distance is considered to be infinity. In this case, the rays from the object are parallel, $1/o$ equals zero, and the image distance equals the focal length. This leads to the definition of the focal point as the place where a lens focuses incoming parallel rays from a distant object. A lens has two focal points, one on each side. The distance from the lens to each focal point is the focal length.

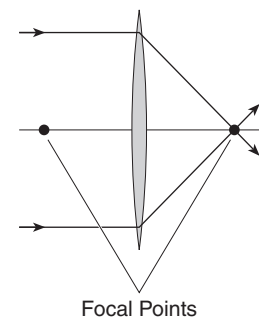

Magnification

The size of an image can be different from the size of the object. The **relative magnification**, $|M|$, of the image is defined by:

$$(eq. 2) \quad |M| = \frac{\text{Image Size}}{\text{Object Size}}$$

If $|M|$ is greater than 1, the image is larger than the object; if $|M|$ is less than 1, the image is smaller.

The **magnification**, M , which can be positive or negative, represents both the size and orientation of the image. It can be defined in terms of the image and object distances:

$$(eq. 3) \quad M = -\frac{i}{o}$$

If M is positive, the image is **upright**, or in the same orientation as the object. If M is negative, the image is **inverted**, or in the opposite orientation to the object. If the object is right-side-up, then the inverted image appears upside-down.

In the pictured example (right), the image is larger than the object and inverted, which means that $|M|$ is less than 1 and M is negative.

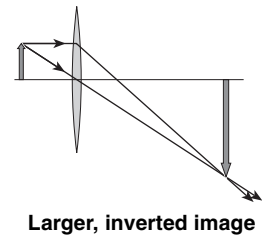

Anatomy of the Eye

The human eye achieves vision by forming an image that stimulates nerve endings, creating the sensation of sight. Like a camera, the eye consists of an aperture and lens system at the front, and a light-sensitive surface at the back. Light enters the eye through the aperture-lens system, and is focused on the back wall.

The lens system consists of two lenses: the **corneal lens** on the front surface of the eye, and the **crystalline lens** inside the eye. The space between the lenses is filled with a transparent fluid called the **aqueous humor**. Also between the lenses is the **iris**, an opaque, colored membrane. At the center of the iris is the **pupil**, a muscle-controlled, variable-diameter hole, or aperture, which controls the amount of light that enters the eye.

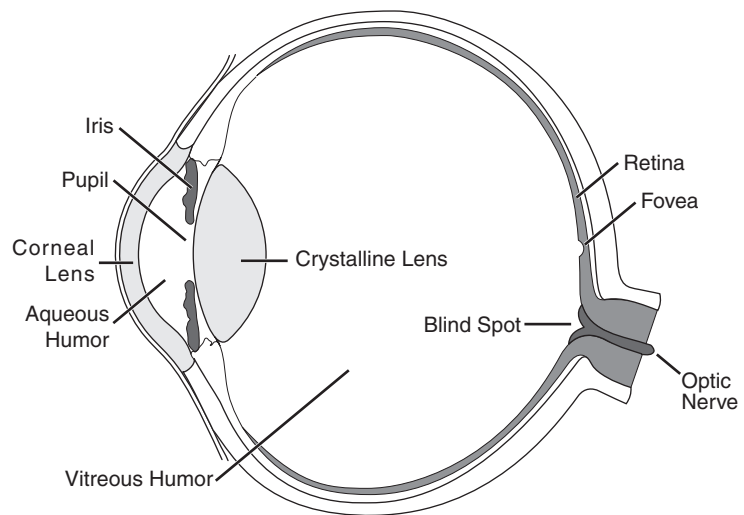

Horizontal Cross Section of the Human Eye

The interior of the eye behind the crystalline lens is filled with a colorless, transparent material called the **vitreous humor**.

On the back wall of the eye is the **retina**, a membrane containing light-sensitive nerve cells known as **rods** and **cones**. Rods are very sensitive to low light levels, but provide us only with low-resolution, black-and-white vision. Cones allow us to see in color at higher resolution, but they require higher light levels. The **fovea**, a small area

near the center of the retina, contains only cones and is responsible for the most acute vision. Signals from the rods and cones are carried by nerve fibers to the **optic nerve**, which leads to the brain. The optic nerve connects to the back of the eye; there are no light-sensitive cells at the point where it attaches, resulting in a **blind spot**.

Optics of the Eye

The corneal lens and crystalline lens together act like a single, convergent lens. Light entering the eye from an object passes through this lens system and forms an inverted, real image on the retina.

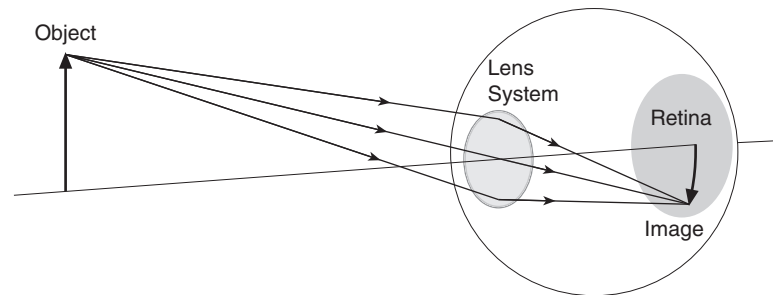

The eye focuses on objects at varying distances by **accommodation**, or the use of muscles to change the curvature, and thus the focal length, of the crystalline lens.

In its most relaxed state, the crystalline lens has a long focal length, and the eye can focus the image of a distant object on the retina. The farthest distance at which the eye can accommodate is called the **far point** for distinct vision. For a normal eye, the far point is infinity.

When muscles in the eye contract and squeeze the lens, the center of the lens bulges, causing the focal length to shorten, and allowing the eye to focus on closer objects. The nearest distance at which they eye can accommodate is called the **near point** for distinct vision. The near point of a normal eye is about 25 cm.

Visual Defects and their Correction

A normal eye can focus by accommodation on any object more than about 25 cm away. In cases where an eye cannot focus on an object, the image is formed either behind or in front of the retina, resulting in blurred vision. This can be caused by the eye being too short or too long.

Near-sightedness (Myopia)

A person affected by **myopia** has an eye ball that is too long, making the distance from the lens system to the retina too large. This causes the image of distant objects to be formed *in front of* the retina. The far point of a myopic eye is less than infinity.

A myopic eye can naturally focus divergent rays from a near object on the retina, but not parallel (or nearly parallel) rays from a distant object. Eyeglasses that correct myopia have a divergent lens, which forms a virtual image of the distant object closer to the eye.

Far-sightedness (Hypermetropia)

A person affected by **hypermetropia** has an eye ball that is too short, making the distance from the lens system to the retina too small. This causes the image of near objects to be formed *behind* the retina. The near point of a hypermetropic eye is greater than normal.

A hypermetropic eye can naturally focus parallel (or nearly parallel) rays from a distant object on the retina, but not highly divergent rays from a near object. Hypermetropia can be corrected using eyeglasses that have a convergent lens, which reduces the divergence of incoming rays.

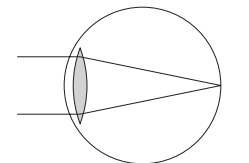

Normal Vision

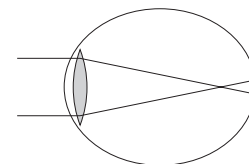

Myopia

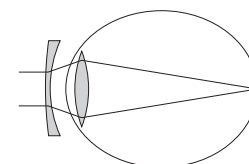

Corrected Myopia

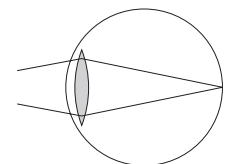

Normal Vision

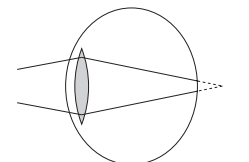

Hypermetropia

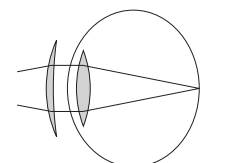

Corrected Hypermetropia

A form of hypermetropia called **presbyopia** (old-sightedness) is not caused by the shape of the eye, but by a change in the crystalline lens: over time, the lens becomes more rigid, making it less able to accommodate to short object distances.

Astigmatism

Astigmatism is a defect caused by a lack of rotational symmetry in the lens system. The lens is not spherical (as in a normal lens) but has two unequal focal lengths. This makes the eye able to focus sharply only on lines of a certain orientation, and all others look blurred. Astigmatism is corrected with a cylindrical eyeglasses lens that has no curvature in one plane and the correct amount of curvature in the other plane. The combination of the eye's defective lens and the cylindrical corrective lens is equivalent to a single symmetric spherical lens. The alignment of the corrective lens is critical; rotating the eyeglasses lens with respect to the eye will ruin the effect.

In the example illustrated (right), the vertical- and horizontal-line objects are at the same distance, but the eye's lens system forms an image of the vertical line at a greater distance than the image of the horizontal line. If the horizontal-line image is formed exactly at the retina then it appears in focus, but the vertical-line image is formed *behind* the retina and appears blurred. The corrective lens causes the vertical- and horizontal-line images to be formed at the same distance.

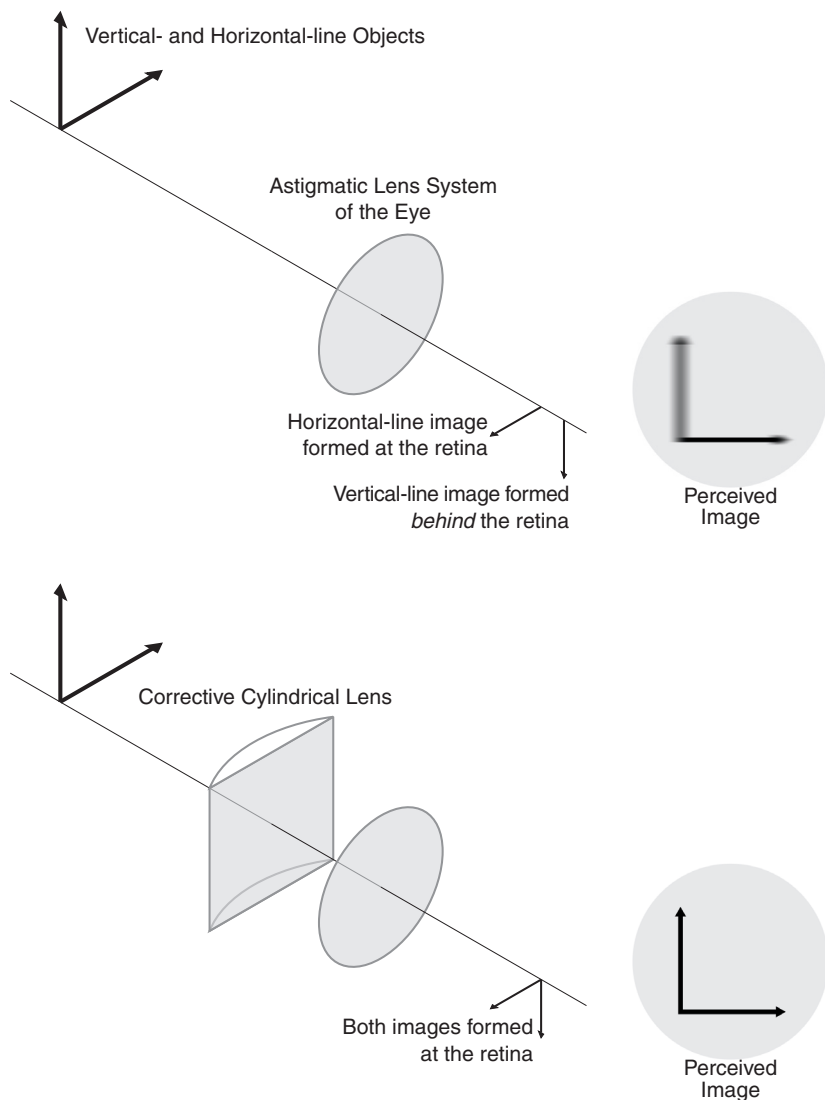

Optical Instruments

Optical instruments enhance vision by forming an image that is a different size or at a different position from the object.

A **magnifying glass** is a single convergent lens used to view near objects. It creates a real, upright image that is larger and farther away. This makes the object appear larger, and it allows the eye to focus on an object that would normally be closer than the eye's near point. The object distance must be less than the

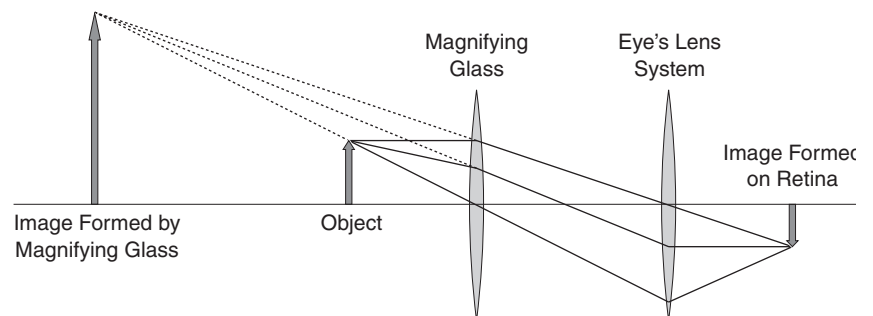

focal length of the lens. Reading glasses can be thought of as a type of magnifying glass that allow you to hold a book nearer than your eyes' near point while viewing a more distant image of the book.

A **microscope** is a combination of two or more lenses that forms a distant image of a near object. In the example illustrated below, a system of two converging lenses forms an upright, real image at infinity.

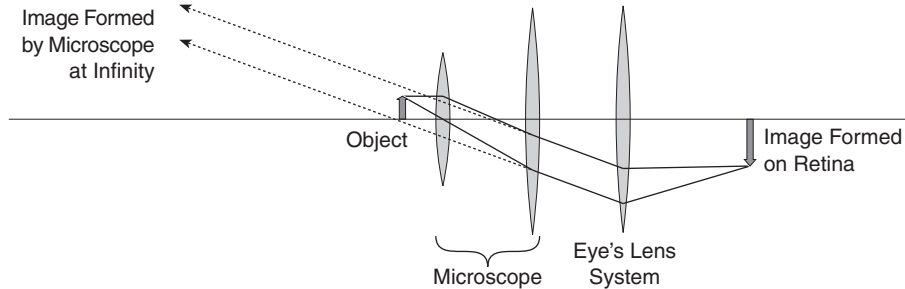

A **telescope** forms a larger image of a distant object. In the example of a simple telescope illustrated below, a system of two converging lenses forms an inverted, real image. Note that the image is *not* closer to the eye than the object; this telescope forms a distant image which can be viewed by the eye in its relaxed state, when it is focused at infinity.

Because its objective lens, or first lens, usually has a larger area than the pupil of the eye, a telescope gathers more light than the unaided eye, and thus can allow the eye to see objects that would normally be too dim to detect.

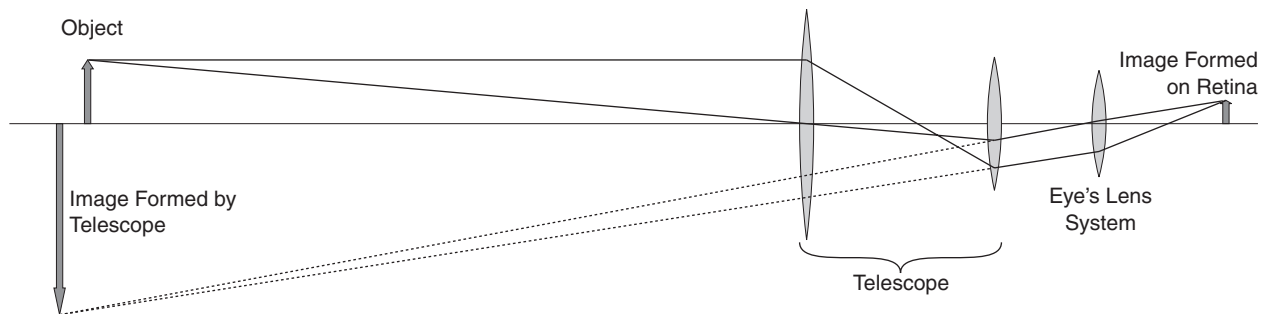

Experiment Setup

This table summarizes the equipment needed for the following experiments. With the exception of the eye model itself, the specific model numbers suggested here can be substituted with similar items from PASCO or other manufacturers. See “Equipment and Procedure Notes” below for details.

Equipment Needed	Model Number
Human Eye Model	OS-8477
Basic Optics Light Source ¹	OS-8470 or part of OS-8515A
Basics Optics System ²	OS-8515A
Mounting Bracket ³	OS-8469
Optics Calipers	OS-8468
Accessory Lens Set ⁴	OS-8519
Large-diameter +200 mm lens ⁴	
Desk Lamp	
“Far” Object (window, door, or lamp)	
Meter Stick or Tape Measure	
Paper Towel	
Water, approximately 1 liter	

¹Or other illuminated “near” object, see below.

²Required only for Experiment 2. Components called for are a 120 cm bench, a light source, lenses with focal lengths of +100 and +200 mm, and a viewing screen.

³For use with Basic Optics System.

⁴Optional for Experiment 2 Further Study.

Equipment and Procedure Notes

Light Sources and Objects

In these experiments, you will use the eye model to form images on the retina screen. The room should be fairly dark to make the images easier to see. It is helpful to have a desk lamp at your lab station that you can turn on and off and shine inside the eye model when you change lenses.

The illuminated screen of the OS-8470 Basic Optics Light Source (or a similar light source) is recommended for use as a “near” object, but a pattern drawn on a sheet of paper and brightly illuminated with your desk lamp will work as well. For informal experimentation, you can use the desk lamp to light up almost any object (such as your hand, a book, or your lab partner’s face) to form an image in the eye model.

In addition to nearby objects, you will need a distance object that the eye model can focus on. A single, small window or open door with a view to the outside works best, but a bright lamp at the far end of the room will do. Make sure that you can position the eye model on your lab bench to see the distant object.

Water

The eye model requires about one liter of water, but do not fill it yet if you are going to do Experiment 1. When you remove lenses from the model, they will be wet; have an absorbent cloth or paper towel ready to lay them on. Do *not* wipe or rub the lenses to dry them; they are made of uncoated plastic and are easily scratched.

Optics Bench

Experiment 2 (the telescope) calls for the optics bench and lenses of the OS-8515A Basic Optics system or OS-8471 Dynamics Track Optics Kit. For the other experiments, an optics bench is not required, but can be useful for measuring distances. To raise the eye model to the optical axis of the lenses, use the OS-8469 Eye Model Mounting Bracket (with the OS-8515A system) or a book about 5 cm thick (with either type of bench). Any other optics bench system will also work if you can position the eye model at the level of the lenses. Experiment 2 calls for lenses with focal lengths of +100 mm and +200 mm.

Image Size and Distance Measurement

To quantitatively study magnification, you will need to measure the sizes of underwater images on the retina screen. Since it is difficult to read a ruler under water, the best way to measure the image size is with a pair of dividers or OS-8468 Optics Calipers. Dip the calipers into the water and adjust them to span the side-to-side width of the image; then bring them out of the water and measure the span.

Use a meter stick or tape measure to measure the distance between near objects and the eye model. (It is not necessary to measure the distance to the “far” object.) If you are using an optics bench, you can use the scale on the bench, but you may find it easier to use a ruler to measure distances between components inside the eye model.

Clean Up

Do not wipe or rub the lenses to dry them. Wet lenses can be placed in the foam holder. After removing the lenses and retina screen, carefully pour the water out through the spout on the back rim of the eye model. Allow all parts to dry before storing them in a closed space.

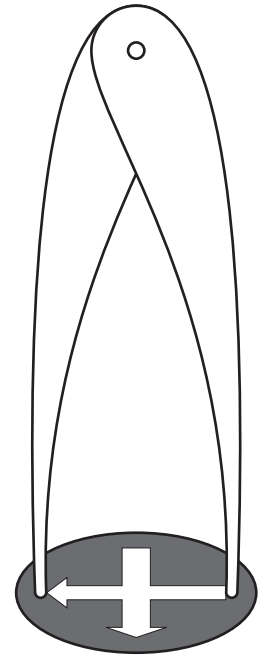

Use dividers or Optics Calipers to measure the width of an image on the retina

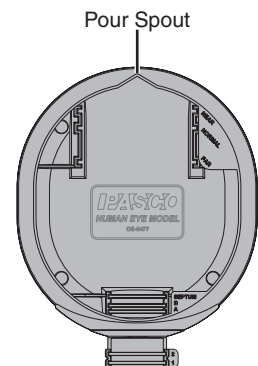

Experiment 1: Optics of the Human Eye

In this experiment you will study how images are formed on the retina of the eye. Before you start, draw a diagram of the eye model and identify the parts of the human eye represented by each part of the model.

Part 1: Images Formed in the Eye

Procedure

1. Do not fill the eye model with water yet. Put the retina screen in the middle slot, marked NORMAL. Put the +400 mm lens in the slot labeled SEPTUM.
2. Put your hand in front of the eye model, about 50 cm from the cornea. Use your desk lamp to brightly illuminate your hand. Can you see an image on the retina screen? Move your hand up, down, left, and right. How does the image move?
3. Draw an asymmetrical picture on a sheet of paper and hold it in front of the eye model. Is the image of your picture on the retina inverted? Turn the picture upside down. How does the image look now? Sketch the retina image and draw a copy of the original picture next to it.

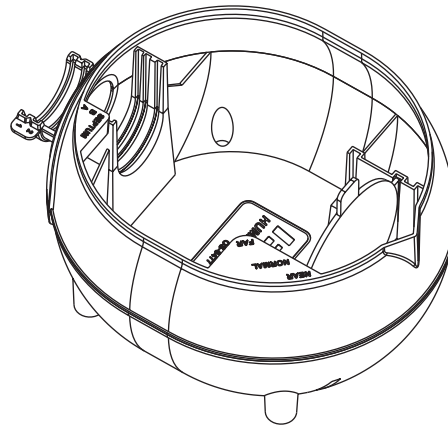
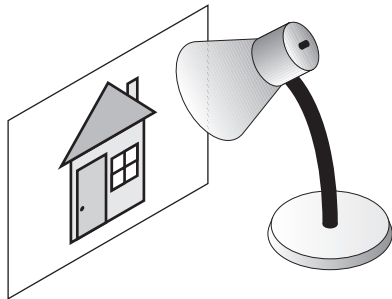
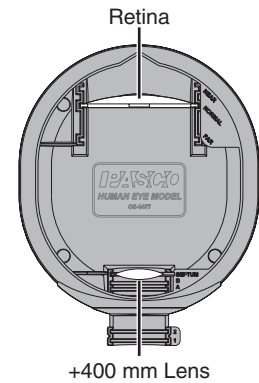

Questions

1. Since the image on the retina is inverted, why do we not see things upside down?
2. If you wrote something on a piece of paper and held it upside down in front of the eye, how would it look on the retina? Would you be able to read it easily?

Part 2: Accommodation

In the process of accommodation, muscles in the eye change the shape of the crystalline lens to change its focal length. Accommodation in the eye model is simulated by changing the lens or lenses that represent the crystalline lens.

Procedure

1. Do not fill the eye model with water yet, and leave the +400 mm lens in the SEPTUM slot. Position the eye model about 35 cm from the light source, with the eye looking directly at the illuminated screen.

Can you see the image on the retina? Move the eye model further away from the object until the image is in focus. Note the position of the eye model so you can return it to the same place after you fill it with water.

2. Fill the eye model with water to within 1 or 2 cm of the top. Return it to the same position as in step 1.

Is the image still in focus? Try changing the distance; can you get it to focus? Explain. What effect do the aqueous and vitreous humors (modeled by the water) have on the focal length of the eye's lens system?

3. Place the eye model about 35 cm from the light source. Replace the +400 mm lens in the SEPTUM slot with the +62 mm lens.

Is the image in focus now? Move the eye model as close as possible to the light source while keeping the image in focus. Describe the image on the retina screen.

4. Measure the object distance, o , from the screen of the light source to the top rim of the eye model, as pictured below. (The front of the rim is a convenient place to measure to and marks the center of the eye model's two-lens system.) Record this distance, which is the **near point** of the eye model when equipped with the +62 mm lens. The average human eye has a near point for distinct vision of about 25 cm.

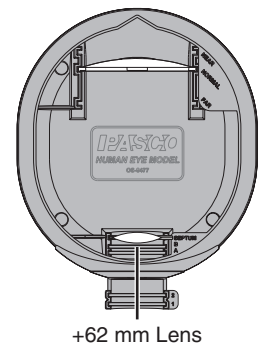

5. The optics of a two-lens system can be simplified looking at the combined effect of the lenses and the total *effective* focal length of the system. Measure the image distance (i), from the model's rim to the handle of the retina. Calculate the total *effective* focal length (f) of the two-lens system using the thin lens formula:

$$\frac{1}{f} = \frac{1}{i} + \frac{1}{o}$$

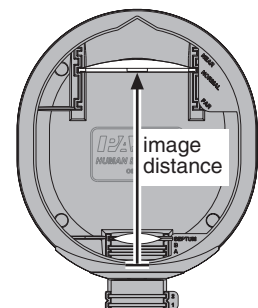

6. Increase the ability of the eye model to focus on a close object by adding the +400 mm lens to slot B. This combination models a different focal length for the crystalline lens.

How close can the eye focus now?

7. Keep the +400 mm lens in slot B and replace the lens in the SEPTUM slot with the +120 mm lens.

At what distance does the model eye focus now? What does a real human eye do to change the focal length of its crystalline lens?

8. Remove both lenses and place the +62 mm lens in the SEPTUM slot. Adjust the eye-source distance to the “near point” distance for this lens (which you found in step 4) so that the image is in focus. While looking at the image, place the round pupil in slot A.

What changes occur in the brightness and clarity of the image? Move the light source several centimeters closer to the eye model. Is the image still in focus? Remove the pupil and observe the change in clarity of the image. Both with and without the pupil, how much can you change the eye-source distance and still have a sharp image?

Predict what will happen to the image when you place the “cat’s pupil” in slot A. Try it and record your observations.

9. Make a detailed drawing showing the object, image, pupil, and *both* lenses. Identify which lens models the corneal lens and which models the crystalline lens.
10. Position the eye model (with pupil removed) so that it is looking towards a *distant* object. Is the image on the retina in focus? Replace the lens in the SEPTUM slot with one that makes a clear image of the distant object; this is the **far-vision lens**. Record the focal length marked on the handle of the lens.

11. Calculate the total *effective* focal length of the lens system, as you did in step 5. What value should you use as the object distance for *far* vision? How do you enter that value into a calculator? (Hint: as the object distance, o , increases towards infinity, the inverse of the object distance, $1/o$, decreases towards zero.)

12. One treatment for cataracts is to surgically remove the crystalline lens. Remove the crystalline lens from the eye model and observe the image of the distant object on the retina. Can an unaided eye without a crystalline lens focus on distant objects?

Place the +400 mm lens in slot 1 to act as an eyeglasses lens. Does this restore clear vision? Turn the eye model to look at the nearby light source. Can you adjust the near object distance to form a clear image? Replace the eyeglasses lens in slot 1 with the +120 mm lens. Now can you adjust the object distance to form a clear image?

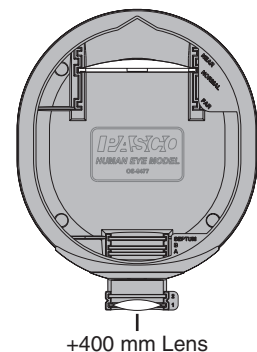
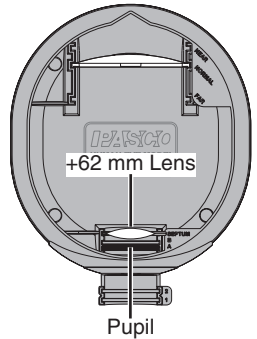
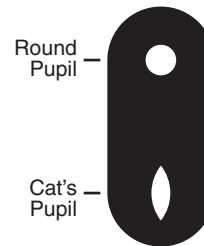
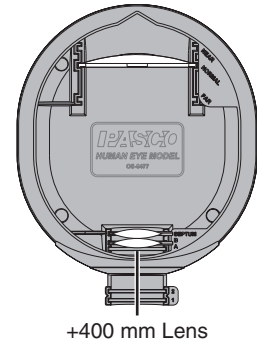

Questions

1. Compare the crystalline lens needed for far vision to the crystalline lens needed for near vision? Which lens is more curved? When you look through them, which lens appears to be stronger? Compare the effective focal lengths (of the two-lens systems) for near and far vision that you calculated in steps 5 and 11.

- In step 11, the effective focal length (f) and the image distance (i) were the same. Why? For what special case does f equal i ?
- In a real human eye, accommodation is accomplished by muscles that change the curvature of the crystalline lens. When an eye changes accommodation from a distant object to a near object, does the curvature of the crystalline lens increase or decrease? Why does the eye's range of accommodation decrease with age?
- In step 12, you showed that, with the aid of eyeglasses, it is possible to focus an image after the crystalline lens has been removed. Is this an ideal solution for cataract patients? Explain. (Hint: which lens is responsible for accommodation? What would a person without crystalline lenses need to do to clearly see objects at different distances?) How do modern cataract treatments improve upon this older surgical technique?

Part 3: Far-sightedness (Hypermetropia)

A person affected by hypermetropia has a shorter-than-normal eye ball, making the retina too close to the lens system. This causes images of near objects to be formed behind the retina.

Procedure

- Set the eye model to normal near vision (put the 62 mm lens in the SEPTUM slot, remove other lenses, and make sure the retina is in the NORMAL position). Position the eye to look at the nearby light source. Adjust the eye-source distance to the near-point distance so that the image is in focus.
- Move the retina screen to the forward slot, labeled FAR. Describe what happens to the image. This is what a far-sighted person sees when trying to look at a near object.

Decrease the pupil size by placing the round pupil in slot A. What happens to the clarity of the image? Remove the pupil.

- Turn the eye model to look at the distant object, and describe the image. Does a far-sighted person have trouble seeing distant objects? Why was it not necessary to change the lens to look far away?
- Return the eye model to looking at the nearby light source. You will now correct the hypermetropia by putting eyeglasses on the model. Find a lens that brings the image into focus when you place it in front of the eye in slot 1. Record the focal length of this lens.

Rotate the eyeglasses lens in the slot. Does this affect the image on the retina?

- A corrective lens is not usually described by its focal length, but rather by its light-bending **power**, which is measured in units called **diopters**. To calculate a lens's power in diopters, take the reciprocal of its focal length *in meters*.

What is the power of the eyeglasses lens that you selected for the model eye?

- Make sure that the image is still in focus. Remove the eyeglasses.

Add the +120 mm lens in slot B to simulate what happens when the crystalline lens increases its power by accommodation. Does the image become sharper? This shows that the eye can compensate for hypermetropia if it can accommodate sufficiently.

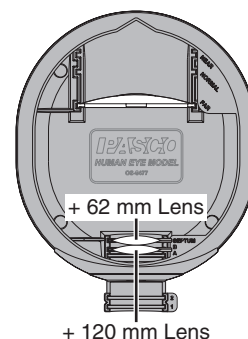
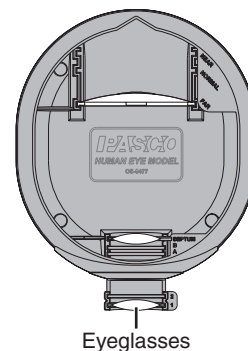
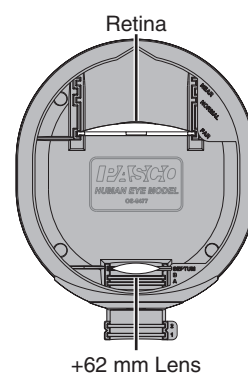

Questions

1. Why did reducing the pupil size make the image clearer? Would a person with hypermetropia see better in bright light or in dim light?
2. Does a strong lens (high power) have a long or short focal length? What are the power and focal length of a thin, flat piece of glass with no curvature? Look carefully at the +62 mm and +400 mm lenses. Which lens has the greater curvature?
3. To correct hypermetropia, is it necessary to move the image formed by the eye closer to or farther from the eye's lens system? Does this require a convergent or divergent lens? Does this corrective lens add to or subtract from the light-bending power of the eye's lens system?
4. Are the surfaces of the corrective lens that you used on the eye model concave or convex?

On real eyeglasses, each lens has one convex surface and one concave surface. To correct hypermetropia, which surface must be more curved?

5. Does a hypermetropic eye have a far point that is too near, or a near point that is too far?
6. When wearing eyeglasses, a person sees a virtual image of an object rather than the object itself. For hypermetropia, is the distance between the eye and that image greater or less than the distance between the eye and the object?
7. In step 6 of the procedure, you showed that the eye can compensate for hypermetropia by accommodation. Why might this compensation be insufficient to allow a person to read without glasses? Why would the ability of the eye to compensate for hypermetropia decrease with age?

Part 4: Near-sightedness (Myopia)

A person affected by myopia has a longer-than-normal eye ball, making the retina too far away from the lens system. This causes the image of a far-away object to be formed in front of the retina.

Procedure

1. Set the eye model to normal, near vision (put the +62 mm lens in the SEPTUM slot, remove other lenses, and put the retina screen in the NORMAL position). With the eye model looking at the nearby light source, adjust the eye-source distance so that the image is in focus.
2. Move the retina screen to the back slot, labeled NEAR. Describe what happens to the image.

Decrease the pupil size by placing the round pupil in slot A. What happens to the clarity of the image? Remove the pupil.

3. You will now correct the myopia by putting eyeglasses on the model. Find a lens that brings the image into focus when you place it in front of the eye in slot 1. Record the focal length of this lens. Calculate its power in diopters. Does rotating the eyeglasses lens in the slot affect the image?

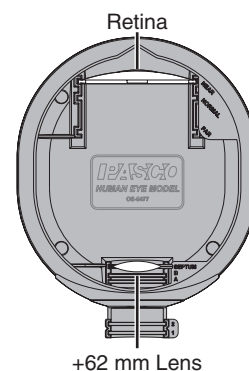

- Remove the eyeglasses. Adjust the eye-source distance so that the image is in focus. Is this distance different from the normal near-point distance you found in step 1. Why?
- Turn the eye model to look at the distant object. Describe the image. Replace the lens in the SEPTUM slot with the normal far-vision lens (which you found in Part 1, step 10, on page 15).

Is the image in focus? This is what a near-sighted person sees when trying to look at a far-away object.

The lens in the SEPTUM slot represents the crystalline lens in its most relaxed state, with its longest-possible focal length. Can an eye compensate for myopia by accommodation?

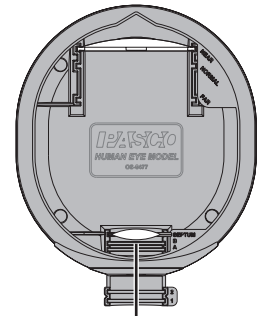

Far-vision Lens

Questions

- Why did reducing the pupil size make the image clearer? Would a person with myopia see better in bright light or in dim light?
- To correct myopia, is it necessary to move the image formed by the eye closer to or farther from the eye's lens system? Does this require a convergent or divergent lens? Does this corrective lens add to or subtract from the light-bending power of the eye's lens system? Is the curvature of this lens concave or convex?
- Look at the corrective lens that you selected. Are the surfaces concave or convex?

On a real eyeglasses lens, with one convex surface and one concave surface, which surface must be more curved to correct myopia?

- Does an eye with myopia have a far point that is too near, or a near point that is too far?
- For myopia, is the distance between the eye and the image formed by the eyeglasses lens greater or less than the distance between the eye and the object?
- On the eye model, the positions for the retina screen are labeled NORMAL, FAR, and NEAR. Why is the position labeled NEAR *farthest* from the lens? What does the word NEAR refer to?

Part 5: Astigmatism

In a normal eye, the lens surfaces are spherical and rotationally symmetrical; but an eye with astigmatism has lens surfaces that are not rotationally symmetrical. This makes the eye able to focus sharply only on lines of certain orientations, and all other lines look blurred. Astigmatism can be corrected with a cylindrical eyeglasses lens that is oriented to cancel out the defect in the eye.

Each cylindrical lens included with the eye model has its cylindrical axis marked by two notches in the edge.



Procedure

1. The figure below is a test chart for astigmatism. All of the lines are printed the same thickness and brightness, but a person with astigmatism sees some lines as darker than others.

Cover one eye and look at the chart. Do some of the lines look darker than others? If they do, rotate the figure 90° to convince yourself that the lines are actually the same and it is only your eye that causes the effect. If you wear glasses, look at the figure both with and without your glasses. Try rotating your glasses in front of your face while looking at the chart through one of the lenses.

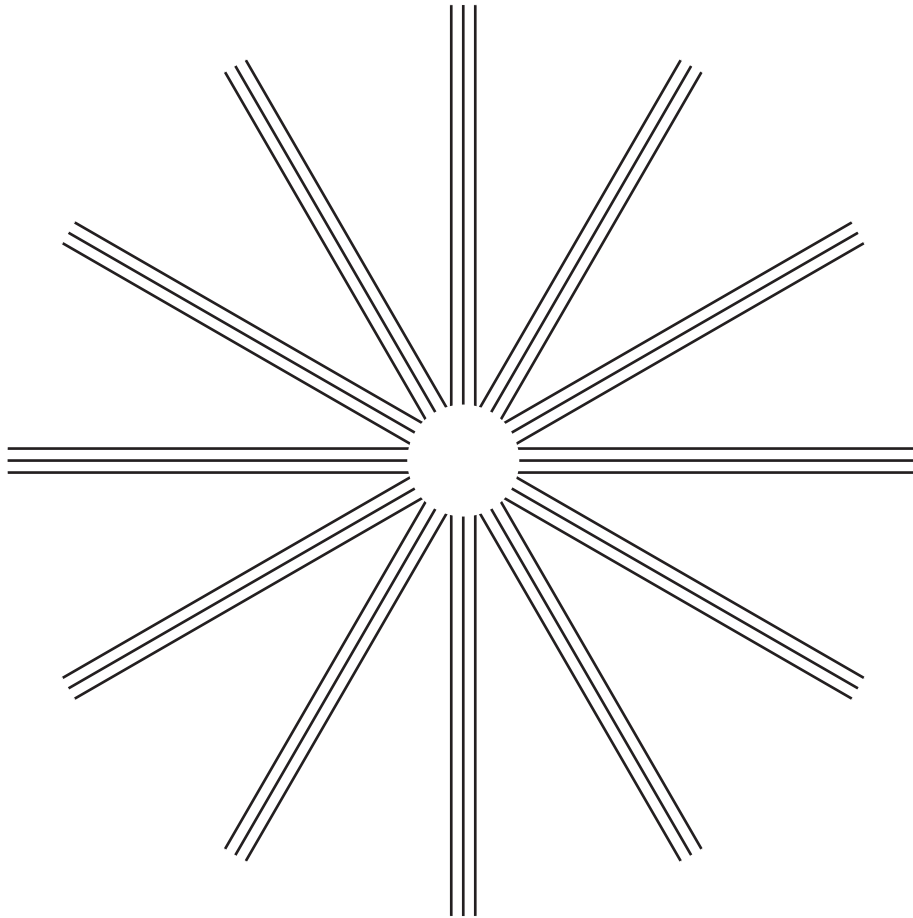

Astigmatism Chart

2. Set the eye model to normal, near vision (put the +62 mm lens in the SEPTUM slot, remove other lenses, and put the retina screen in the NORMAL position). With the eye model looking at the nearby light source, adjust the eye-source distance so that the image is in focus.
3. Place the -128 mm cylindrical lens in slot A. The side of the lens handle marked with the focal length should be towards the light source. Describe the image formed by the eye with astigmatism.
4. Rotate the cylindrical lens. What happens to the image? This shows that astigmatism can have different directions depending on how the defect in the eye's lens system is oriented.

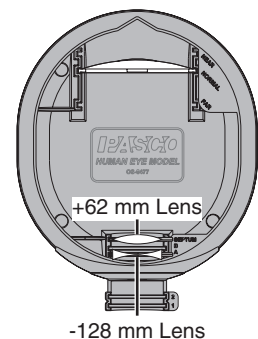

- You will now correct the astigmatism with eyeglasses. Place the +307 mm cylindrical lens in slot 1. The side of the lens handle marked with the focal length should be towards the light source.

Rotate the corrective lens and describe what happens to the image. Find the orientation of the eyeglasses lens at which the image is sharpest. What is the angle between the cylindrical axes of the crystalline lens and the corrective lens?

- An eye can have more than one defect. Make the eye model have both astigmatism and hypermetropia (far-sightedness) by moving the retina screen to the FAR slot. Which additional eyeglasses lens do you have to put in slot 2 to bring the image back in focus?
- (Optional) If someone in your lab group has eyeglasses, try holding them in front of the eye model. What type of vision problems do you have to give the eye model so that the eyeglasses improve its vision?

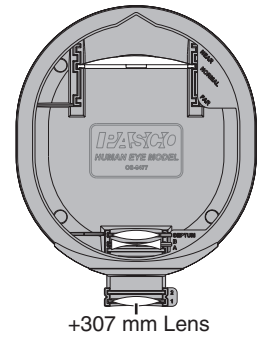

Questions

- Why does rotating the corrective lens for astigmatism affect the image, but rotating a corrective lens for hypermetropia or myopia does not? What test could you do to find out if a person's eyeglasses had a correction for astigmatism? Does anyone in your lab group wear glasses that correct astigmatism?
- Look carefully at the -128 mm lens edge on, along the axis marked by the two notches. What shape do you see? Why is this lens described as cylindrical?
- In step 6, you corrected the compound defect by using two lenses. How would a real eyeglasses lens be made to correct both astigmatism and hypermetropia?

Part 6: Blind Spot

The blind spot is the small area on the retina where the optic nerve is attached. There are no rods or cones in the blind spot so it is insensitive to light.

Procedure

- Cover your left eye and look at the figure below *with only your right eye*. Hold the paper at arm's length and stare at the plus sign with your right eye. To the right, in your peripheral vision, you should be able to see the dot. Do not look directly at the dot; stare at the plus sign as you slowly move the paper closer to your eye. At a distance of about 30 cm, does the dot disappear? Keep moving the paper closer. Does the dot re-appear?



- What you “see” due to the blind spot is not a hole in the image, but an area where your brain fills in the missing details. Repeat the exercise with the figure below and adjust the distance so that the dot disappears. Do you see a white spot where the dot should be, or do the lines appear to intersect? Try making your own patterns. You will find that your brain is very good at filling in (making up) the missing details. Try different colors.

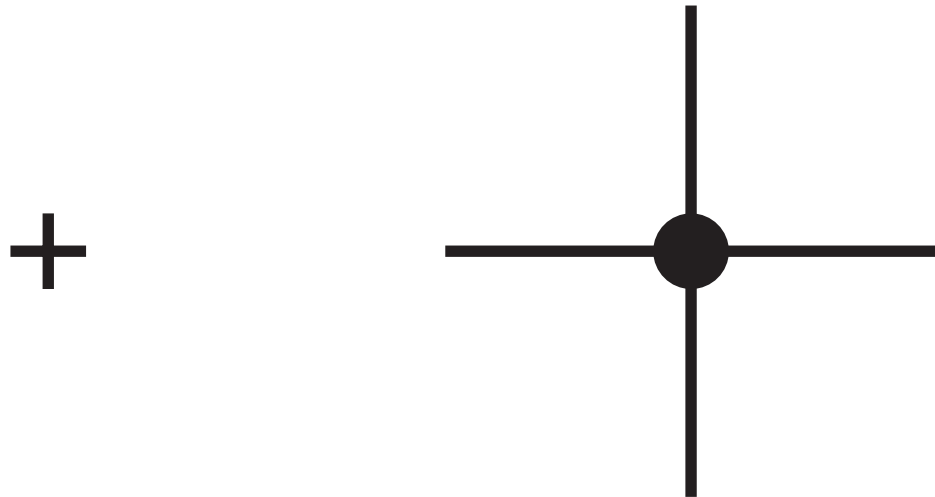

- Set the eye model to normal, near vision (put the +62 mm lens in the SEPTUM slot, remove other lenses, and put the retina screen in the NORMAL position).
- Make a copy of the above figure on a separate sheet of paper. Hold it about 30 cm from the front of the eye model and shine a desk lamp on the paper. Do you see an image of the figure in the eye model? Adjust the object distance so that the image is in focus.

The blind spot of the model eye is represented by a hole in the retina screen. Can you adjust the position of the paper so that image of the small plus sign appears near the center of the retina and the dot falls on the blind spot?

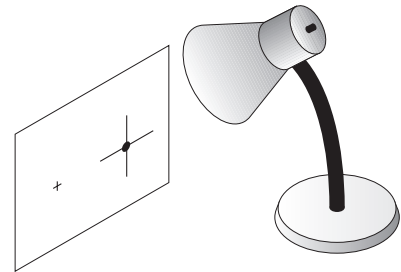

Make a sketch of the retina screen and the image on it.

Which part of the paper does the eye model appear to be looking directly at?

Questions

- In order to repeat the blind-spot exercise in step 1 with your *left eye*, what do you have to do differently?
- Try repeating the blind-spot exercise, but look at the image with both eyes. Why does it not work?
- Does the screen in the model eye represent the retina of a left eye or a right eye? Explain.

Part 7: Apparent Size

When you look at something, its apparent size is determined by the size of the image formed on your retina, which depends both on the size of the thing and its distance from your eye. Hold your hand close to your face and look at it while you also look at a large, distant object (a chair on the other side of the room, for instance). Which

object is larger? Which one appears to be larger? Which one do you think forms a larger image on your retina?

Procedure

1. Set the eye model for normal, near vision (with the +62 mm lens in the SEPTUM slot). With the eye model looking at the nearby light source, adjust the eye-source distance so that the image is in focus. Measure the object size, object distance, image size, and image distance. Draw a sketch of the retina and image.
2. Set the eye model for medium-distance vision (put the +120 mm lens in the SEPTUM slot and the +400 mm lens in slot B). Increase the object distance until a clear image forms on the retina again. Measure the object distance and the image size. Have the object size and image distance changed? Draw another sketch of the retina and image.

Questions

1. Was the image on the retina larger with the nearer object distance (o_1) or the farther object distance (o_2)?
2. Did the image size change because you changed the power of the crystalline lens? Look at the image on the retina again and remove the +400 mm lens (leaving the +120 mm lens in place). The image becomes blurry, but does its size change?
3. Replace the +400 mm lens and move the object back and forth. Does the image size change when you change the object distance without changing the power of the crystalline lens?
4. Make a copy of this diagram and label it with the object size, image size, object distance, and image distance that you measured in step 1 of the procedure. Show that the two triangles in the diagram are similar.
5. Make another diagram illustrating the object size, image size, object distance, and image distance from step 2 of the procedure. Use the same horizontal and vertical scales as the first diagram. Show that the two triangles in this diagram are similar to each other but different from the triangles in the first diagram.
6. On a blank sheet of paper, draw a large object. Measure its size. Place the object at distance o_2 from the eye model and illuminate the paper with a desk lamp. Measure the size of the image on the retina screen. Can you draw another, smaller object that will form the same-size image on the retina when placed at distance o_1 ? What size would the smaller object have to be? (Hint: refer to your diagrams and think about similar triangles.)
7. On another sheet of paper, draw the smaller object at the size you calculated, set the eye model for near vision (with the +62 mm lens), and test your calculation. Is the image on the retina the same size?

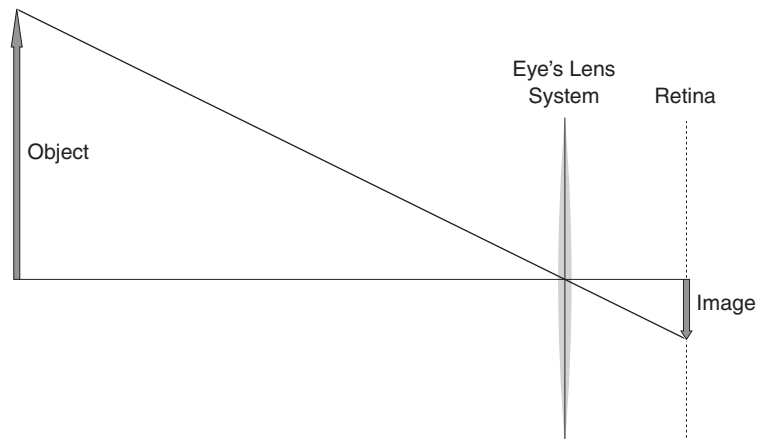

- Hold the smaller object in front of your own eye at distance o_1 . At the same time, have your lab partner hold the large object at distance o_2 . Do both objects appear to be the same size? Since they form the same size images on your retina, how can you tell which object is actually larger?

Part 8: Magnification

The average eye can not focus on (accommodate) an object closer than about 25 cm. A magnifying glass allows the eye to clearly see a very near object by forming an image that is farther from the eye. Even though the image is farther away than the object, it is also larger than the object, so the apparent size of the image is greater.

Procedure

- Hold the +120 mm lens in front of your eye and look through it at a nearby object. Move the object as close as possible to your eye while keeping it in focus.

Now look at the object at the same distance, but without the lens. Can you see it clearly?

Move the object away from your eye so you can see it in focus. Can you see as much detail on the object as you could when looking through the lens?

- Look through the lens again, but this time try to look at something further away. Can you clearly view an object more than 120 mm from the lens? What is the approximate distance between your eye and the lens? Describe what you see. Is the lens functioning as a magnifier?
- With the eye model set for normal, near vision (with the +62 mm lens in the SEPTUM slot), focus the image of the light source on the center of the retina screen.
- The small circle near the center of the retina screen represents the fovea, the area of the retina responsible for the most acute vision. How big is the image compared to the fovea? Draw a sketch of the image and fovea.
- To see more detail, the size of the image needs to be bigger so that the part of the image you are trying to look at fills the fovea. To accomplish this, place the +120 mm lens in front of the eye in slot 1 to act as a magnifying glass. Adjust the eye-source distance to focus the image. Now what is the size of the image compared to the fovea? Draw another sketch of the image and fovea.

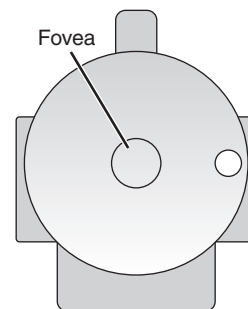

Questions

- What is the distance between the eye and the object? Can the eye model accommodate at this distance without the magnifying glass?
- When the eye model is focused on an object through the magnifying glass, is the image on the retina screen bigger than the object? If not, why does the magnifying glass make things appear larger? (Hint: compare the image size with the magnifying glass to the image size without the magnifying glass.)
- Use the thin lens formula to calculate the image distance of the virtual image formed by the magnifying glass. Calculate the magnification of this virtual image. Why is this magnification different from the magnification of the image on the retina?

Experiment 2: Telescope

In this experiment you will build a telescope and use it to view the light source, both with your own eye and with the model eye.

Procedure

1. Place the light source on the optics bench. Align the illuminated object screen with the 0 cm mark.
2. Place the +200 mm glass lens on the bench at the 51 cm mark and the +100 mm glass lens at the 93 cm mark. These two lenses make up the telescope.
3. Look through the two lenses at the light source. Compare the image that you see through the telescope to the object as it appears when you look at it directly from the same distance. Estimate the magnification. Does it matter how far your eye is from the telescope lens? Is the image inverted?

Draw side-by-side sketches of image viewed through the telescope and the object viewed directly showing their orientations and apparent sizes.

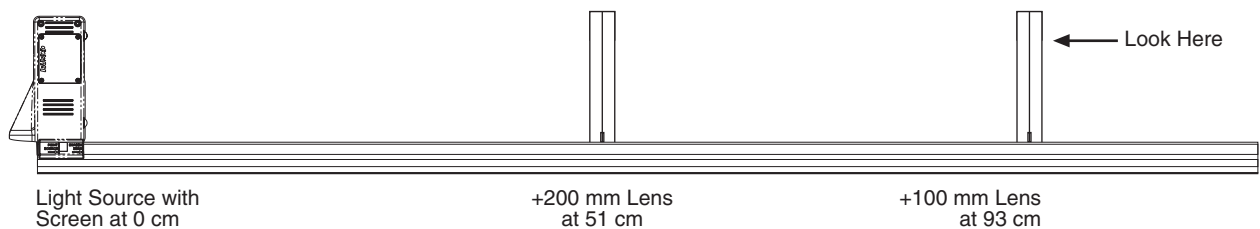

4. Fill the eye model with water. Set it for normal, medium-distance vision with the +120 mm lens in the SEPTUM slot, the +400 mm lens in slot B, and the retina screen in the NORMAL slot. This makes the eye accommodate (or focus) at a distance of about 1 meter.
5. Use the mounting bracket or a stack of books to position the eye model at the height of the telescope lenses with the corneal lens at the 100 cm mark.
6. Observe the image on the retina screen. Is it in focus? What happens to the image when you slightly adjust the positions of the two telescope lenses? Return them to their original positions. Is the image inverted? Measure the width of the image. Draw a sketch of the retina and image.

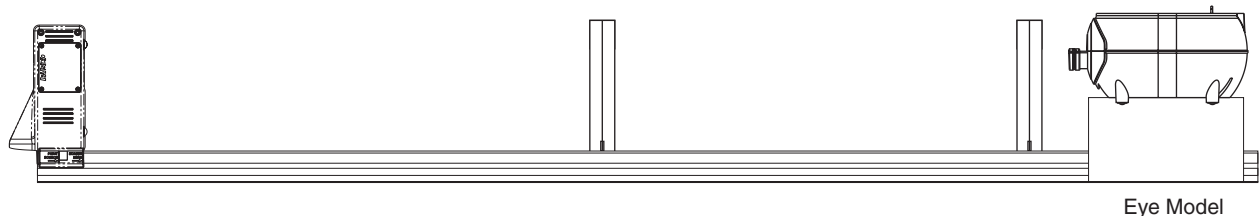
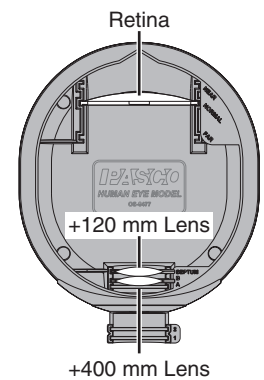

7. Without changing anything else, remove the telescope lenses. Can you still see an image on the retina screen? Is it inverted? Is it larger or smaller than the image

formed with the telescope? Measure the width of the image. Draw another sketch of the retina and image.

Analysis

1. Divide the retina image size viewed with the telescope by the retina image size without the telescope. This is the *angular* magnification of the telescope.
2. The focal length (f_1) of the first lens (Lens #1) is 20 cm, and the object distance (o_1) is 51 cm. Use the thin lens formula to calculate the image distance (i_1) of the image formed by Lens #1.
3. Is this image (Image #1) in front of or behind Lens #1? Is it real or virtual?
4. Calculate the magnification (M_1) of Image #1.
5. Does the value of M_1 tell you that the image is larger or smaller than the object? What does the sign of M_1 mean?
6. Place a screen at the position you calculated for Image #1. Can you see the image on the screen? What does this tell you about the type of image? Is Image #1 larger or smaller than the object? Is it inverted?
7. Make a scaled ray diagram that includes the light source object, both lenses, and the eye model. Pick a horizontal scale that makes your drawing at least 10 cm wide. Exaggerate the vertical scale to make the object on the light source and the lenses several centimeters tall. Mark the focal points of the telescope lenses, label all parts, and indicate all known horizontal distances.
8. Use ray tracing to find the position and height of Image #1. Extend the rays after they cross until they meet Lens #2.
9. Image #1 is the same thing as Object #2 (the object for Lens #2); but the object *distance* of Object #2 is *not* the same as the image distance of Image #1.

$$\frac{1}{f_1} = \frac{1}{i_1} + \frac{1}{o_1}$$

$$M_1 = -\frac{i_1}{o_1}$$

What is the distance between the lenses? What is the distance between Lens #1 and Object #2? Use these distances to calculate the object distance (o_2) between Object #2 and Lens #2. Mark o_2 on your diagram. Is o_2 negative or positive?

10. Use the thin lens formula to calculate the image distance (i_2) for Lens #2.
11. On what side of Lens #2 is this image formed? If you place a screen at the location of Image #2 do you see the image? Why not? What should you do to see Image #2? Is it real or virtual?
12. Using the image and object distances of both lenses, calculate the total magnification for the telescope, M . How does this compare to what you observed?
13. Finish your ray diagram by adding Image #2 at the position that you calculated. Use the calculated magnification to draw the height of Image #2 to scale. Extend the rays from Lens #2 to show how Image #2 is formed.

$$\frac{1}{f_2} = \frac{1}{i_2} + \frac{1}{o_2}$$

$$M = M_1 M_2 = \frac{i_1 i_2}{o_1 o_2}$$

Questions

1. In most telescopes, the lenses are arranged so that the image distance is infinity. When a normal eye is accommodated at infinity, the muscles that control the curvature of the crystalline lens are relaxed. What is the advantage of a telescope with this design?

2. In your model telescope, the positions of the two lenses were chosen to make Image #2 form at about the same location as the object on the light source. If you adjusted the telescope to form the image at infinity, what would you have to do to the eye model to allow it to clearly see the image?
3. What does the relative magnification of your telescope tell you? For telescopes that form the image at the same location as the object, how does a relative magnification of 4 appear different from a relative magnification of $\frac{1}{4}$?
4. What does the sign of the magnification tell you? What is the difference between a telescope with a magnification of 4 and one with a magnification of -4?
5. The simple telescope that you constructed forms an image that is inverted from the object; thus, anything you look at through the telescope appears up-side-down. Look again at the image on the retina screen of the eye model. Is it inverted from the object? Why not?
6. You calculated two magnifications: one was the ratio of the image sizes *on the retina* with and without the telescope. The other was the ratio of the Image #2 size to the Object #1 size. Compare these two values. Draw a diagram illustrating why they were approximately equal in this case.

Further Study

1. **Light Gathering** Replace Lens #1 with a lens that has the same focal length, but a larger or smaller diameter.¹ What changes do you notice in the size and brightness of the image? If you do not have a different lens, cut a hole in a piece of paper and place it in front of Lens #1 to simulate a smaller diameter.
2. **Image at Infinity** Place the +200 mm lens at the 63 cm mark, and the +100 mm lens at the 93 cm mark. Look through the two lenses at a *distant* object. Adjust the model eye for far vision (with the +120 mm lens in the SEPTUM slot). Place the eye model at the 100 cm mark and repeat the measurements and analysis for this telescope. Can you calculate the lateral magnification of Image #2? What is the angular magnification of Image #2?
3. **Microscope** Place the light source on the track with the object at the 0 cm mark. Place the +100 mm lens at the 6 cm mark and the +200 mm lens at the 10 cm mark. Look through the lenses at the light source. Set the eye model for far vision (with the +120 mm lens in the SEPTUM slot) and position it with the corneal lens at the 15 cm mark. Observe the size of the image on the retina screen.
4. **Galilean Telescope** A simple telescope made from two positive lenses is known as an astronomical telescope; a telescope made with a positive objective lens and a negative eyepiece lens is a Galilean telescope. Place the light source on the track with the object at the 0 cm mark. Place the +200 mm lens at the 80 cm mark, and a -150 mm lens² at the 91 cm mark. Look through the lenses at the object. How is this Galilean telescope different from an astronomical telescope? Set the eye model for medium-distance vision (with the +120 mm lens in the SEPTUM slot and the +400 mm lens in slot B) and position it with the corneal lens at the 100 cm mark. Measure the image on the retina. Remove the lenses and measure the retina image without lenses. What is the angular magnification (including the sign) of this telescope?

¹Use the OS-8474 Adjustable Lens Holder.

²Part of the OS-8519 Accessory Lens Set.

Experiment 3: Refraction, a Detailed Study

As light travels from an object to the retina, it crosses several surfaces that mark the boundaries between different media. At each surface, light is bent, or refracted. In Experiment 1, the analysis of the eye model was simplified by treating the series of transitions as a single lens with an “effective focal length.” In this experiment you will analyze the optics in greater detail.

The corneal lens of the eye model is a glass, plano-convex lens with air on the convex side and water on the flat side. The plastic crystalline lens is double-convex with water on both sides. We will treat this system of lenses as consisting of three separate components: the curved surface of the corneal lens, the flat surface of the corneal lens, and the crystalline lens. The image produced by the curved surface of the corneal lens is the object for the flat surface, the image produced by the flat surface is the object for the crystalline lens, and the image produced by the crystalline lens appears on the retina screen.

Theory

Image Produced by a Single Curved Surface

The figure below shows light rays travelling from one medium to another, separated by a curved surface of radius R , similar to the first surface of the corneal lens. As illustrated, the index of refraction of the second medium, n_2 , is *greater than* the index of refraction of the first medium, n_1 .

The relationship between the object distance (o) and the image distance (i) is given by

$$(eq. 4) \quad \frac{n_1}{o} + \frac{n_2}{i} = \frac{n_2 - n_1}{R}$$

Note that the object and image distances are measured from the point on the curved surface where it crosses the optical axis.

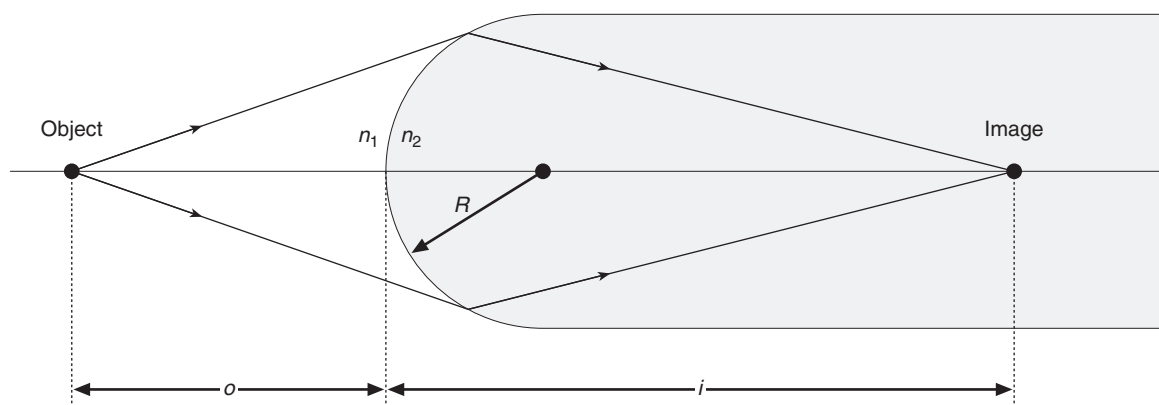
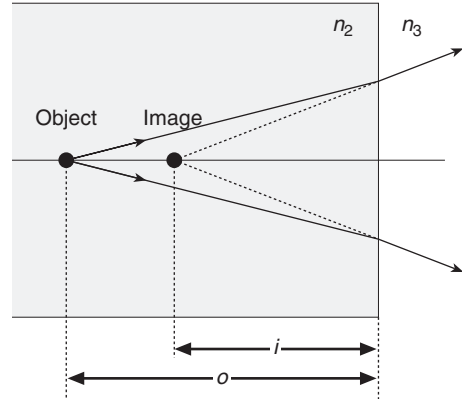

Image Produced by a Single Flat Surface

Even though the interface between the glass corneal lens and the water behind it is flat, it still produces an image. The figure below shows light rays bending as they emerge from one medium (with index of refraction n_2) to another medium (with index of refraction n_3). As illustrated n_3 is less than n_2 . The relationship between the object distance (o) and the image distance (i), is given by

$$(eq. 5) \quad i = -\frac{n_3}{n_2} o$$

Again, the object and image distances are measured from the surface. Following sign conventions, i is negative in this case because it is in front of the surface.



Lens Makers Equation

In the eye model, the crystalline lens is represented by a thin lens with the same curvature on both surfaces. This lens can be treated as a single component.

The **Lens Makers' Equation** relates the focal length of a lens (f) to its index of refraction (n_{lens}), the curvature of its surfaces (R), and the index of refraction of the medium surrounding it (n_{medium}). For a thin, double-convex lens with the same positive curvature on both sides, the equation simplifies to

$$(eq. 6) \quad \frac{1}{f} = \left(\frac{n_{\text{lens}}}{n_{\text{medium}}} - 1 \right) \left(\frac{2}{R} \right)$$

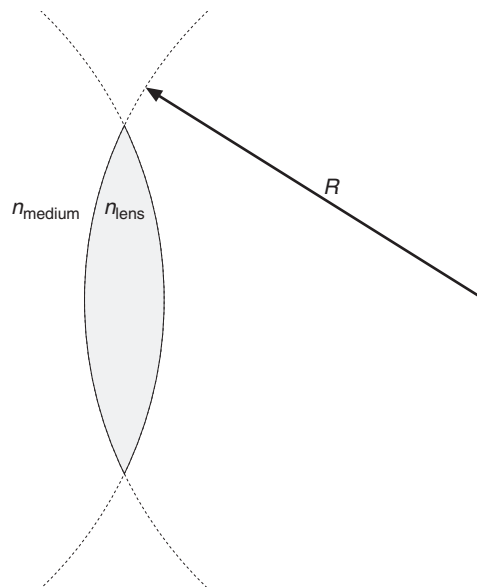

Procedure

1. Fill the eye model with water and set it for normal, far vision (with the +120 mm lens in the SEPTUM slot). Make the eye model look at a *distant* object. The image should be in focus on the retina screen.
2. Draw a sketch of this setup showing the shape of the lens surfaces and the retina screen. On your sketch, indicate the different media (air, glass, water and plastic) that the light travels through. Represent light coming from the infinitely distant object with rays parallel to the optical axis.
3. Show that Equation 4 (for a single, curved surface) reduces to the Equation 7 in the special case of an infinite object distance, with $n_1 = 1$ (for air) and $n_2 = n_{\text{glass}}$.

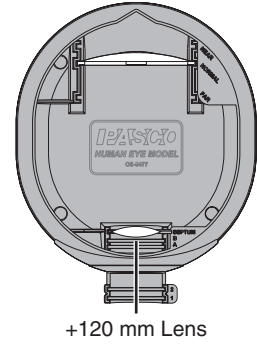

(eq. 7)
$$i = \frac{n_{\text{glass}}}{n_{\text{glass}} - 1} R_1$$

4. For the corneal lens, $n_{\text{glass}} = 1.524$ and $R_1 = 7.10$ cm. Calculate the image distance (i_1) of Image #1 formed by the curved surface.

Indicate on your sketch where this image is. Does it matter that the image is not inside the glass?

5. Image #2 is formed by the flat interface where light crosses from glass to water.

The image formed by the curved surface (Image #1) becomes the object for the flat surface (Object #2). Is Object #2 in front of or behind the flat surface? Is the object distance (o_2) positive or negative? The corneal lens is 0.40 cm thick; calculate o_2 .

Use Equation 5 with $n_3 = n_{\text{water}} = 1.33$ to calculate the image distance (i_2) of Image #2. You should find that i_2 is positive; does this mean that Image #2 is in front of or behind the flat surface?

Add Image #2 to your sketch.

6. The number marked on the handle of the crystalline lens is its focal length *in air*. Since the lens is surrounded by water, its focal length in the eye model is *not* 120 mm. Use Equation 6 to calculate the radius of curvature, R_3 , of the surfaces of the “+120 mm” lens. Assuming that $n_{\text{plastic}} = 1.58$. What value should you use for n_{medium} ?
7. Calculate the focal length, f_3 , of the crystalline lens *in water*.

8. The image formed by the flat surface of the corneal lens (Image #2) becomes the object for the crystalline lens (Object #3). Is the object distance (o_3) positive or negative? The distance from the flat surface of the corneal lens to the center of the crystalline lens is 2.2 cm; calculate o_3 . (For the thin crystalline lens, all distances are measured from the center of the lens.)

Use the thin lens formula to calculate the image distance, i_3 , of Image #3.

$$\frac{1}{f_3} = \frac{1}{i_3} + \frac{1}{o_3}$$

Add Image #3 to your sketch.

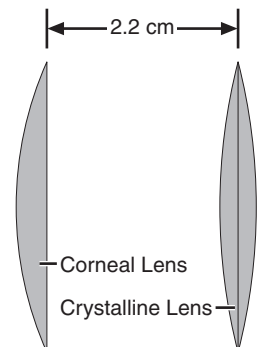

9. Where is Image #3? Can you see it?
10. Measure the distance from the crystalline lens to the retina screen. How does distance compare to your result from step 8?

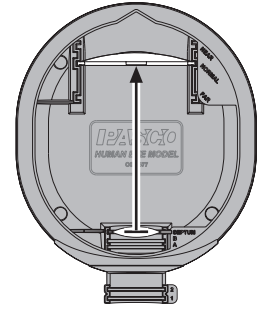

Questions

1. Are Image #1 and Image #2 real or virtual? Why can you not see them?
2. After the parallel rays from the distant object have entered the corneal lens, are they converging or diverging? Do the rays cross inside the lens?
3. Do the rays become more or less convergent when they cross the flat surface from glass to water?
4. If you completely immersed the eye model in water, would the light-bending power of its lens system increase or decrease?
5. For the crystalline lens in the eye model, you used Equation 6 to relate the curvature to the focal length. Why would Equation 6 *not* work for the crystalline lens in a real human eye?

Further Study

The radius of curvature of the lens marked “+62 mm” is 7.2 cm. Put this lens in the SEPTUM slot. Calculate the object distance (o_1) required for an image to be formed on the retina. Test your calculation. Was it correct?

Other Suggested Activities

Flat Mirror

Set the eye model for normal, near vision (with the +62 mm lens in the SEPTUM slot) and focus it on a nearby light source. Note the object distance.

Use desk lamp to brightly illuminate the front of the eye (but shade the retina with your hand or a piece of paper). At what distance must you hold a flat mirror for the eye model to form a clear image of itself on the retina? What is the distance from the eye model to the virtual image formed by the mirror?

Parallax and Stereoscopic Vision

Set the eye model for normal, near vision (with the +62 mm lens in the SEPTUM slot) and focus it on a nearby light source. Have your lab partner hold a pencil vertically about 5 cm in front of the light source (between the light source and the eye model). Use a desk lamp to illuminate the pencil. Adjust the position of the eye model to get both objects in focus and near the center of the retina. Draw a sketch of the retina and image. This image represents what the right eye would see.

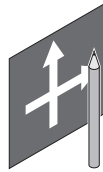

Without moving the objects, move the eye model about 15 cm to the left (to the position where the left eye would be). Adjust the angle of the eye model and its distance from the objects to get the objects in focus near the center of the retina. Sketch this new image. How does the image in the left eye differ from the image in the right eye? How is this difference important to your perception of which object is closer?

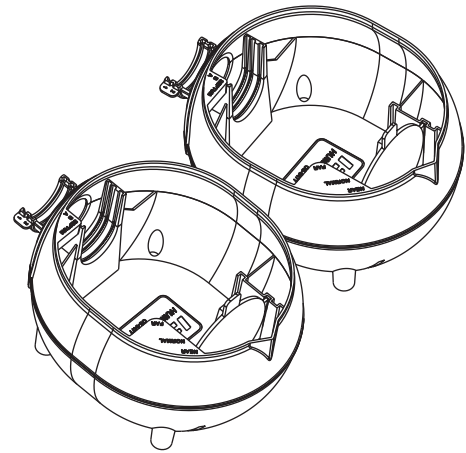

If you have two eye models, set them up next to each other so you can see both images at once.

Examination of the Retina

What does an ophthalmologist see when looking into a person's eye? Set the eye model for far vision (with the +120 mm lens in the SEPTUM slot). Shine a desk lamp into the top of the eye model to light up the retina. Put your own eye very close to the front of the eye model and look in. What do you see? How do the lenses of the eye affect your view of the retina? Put a different crystalline lens in the SEPTUM slot; can you see the difference?

Retinoscopy

Using the method known as retinoscopy, an ophthalmologist examines the refractive properties of the eye by illuminating an area of the retina and observing the image that is formed by light that exits the eye. In this reversal of normal optics, the object (rather than the image) is located at the retina, and the image formed by the eye's lens system can be seen by an outside observer. For this demonstration, you will draw an object directly on the retina and look in through the eye's lenses to view the image.

Stick a piece of clear tape to the center of the retina. Use waterproof ink to draw two very small dots of different colors on the tape about 1 mm apart.

Set the eye for far vision (put the +120 mm lens in the SEPTUM slot) and put the retina screen in the FAR slot. Shine a desk lamp into the eye to brightly illuminate the retina. From a about 3 meters away, cover one eye and look directly into the front of the eye model. Can you see the image of the two dots? Is the image upright or inverted? Move your head left and right. Can you tell by parallax whether the image is in front of or behind the eye model?

Have your partner move the retina to the NORMAL slot. Is the image upright or inverted? Compare this image to the one formed by the far-sighted eye. Which image has the higher angular magnification? Which image is located further from your own eye?

Have your partner move the retina to the NEAR slot. How does the image look different? Is it upright or inverted? Is it in front of or behind the eye model?

Draw ray diagrams or use the thin lens formula to find where the images are formed by the far-sighted, normal, and near-sighted eyes. Compare these results to what you observed. Calculate the magnifications of the images formed by the near-sighted and far-sighted eyes. Can you calculate the magnification of the image formed by the normal eye?

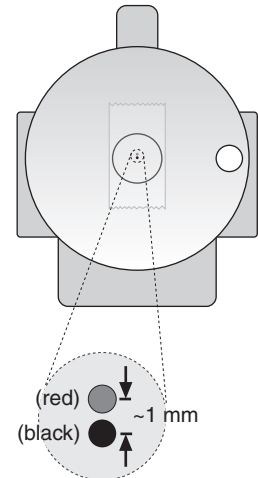

Draw two very small dots on the retina

Teachers' Notes

Experiment 1: Accommodation

Part 1 Students should find that images on the retina are inverted and that the image of an upside-down object looks like a right-side-up mirror image.

Part 2 When filled with water, and with the +62 mm lens in the SEPTUM slot, the eye model accommodates at $o = 35$ cm. The image distance, i , is 12 cm. Thus:

$$\frac{1}{f} = \frac{1}{32 \text{ cm}} + \frac{1}{12 \text{ cm}}$$

$$f = 8.9 \text{ cm}$$

With the +400 mm lens in slot B, and the +62 mm lens in the SEPTUM slot, the eye model accommodates at about 25 cm.

With the +400 mm lens in slot B, and the +120 mm lens in the SEPTUM slot, the eye model accommodates at about 1 m.

To accommodate the eye at infinity, place the +120 mm lens by itself in the SEPTUM slot. Thus:

$$\frac{1}{f} = \frac{1}{\infty} + \frac{1}{12 \text{ cm}}$$

$$f = 12 \text{ cm}$$

Part 3 To correct hypermetropia, place the +400 mm lens in slot 1. The power of this lens is +2.5 diopters.

Part 4 To correct myopia, place the -1000 mm lens in slot 1. The power of this lens is -1.0 diopter.

Part 5 To correct astigmatism, the cylindrical axes of the -128 mm lens in slot A and the +307 mm lens in slot 1 must be parallel.

Part 6 When the eye model is adjusted to have the image of the dot on its blind spot, it appears to be looking directly at the plus sign. The retina screen represents the retina of a right eye.

Part 7 When the object is moved farther away, the image size decreases. The object distances are $o_1 = 35$ cm and $o_2 = 100$ cm. The ratio of the sizes of the two object drawn to appear the same size at these distances should equal o_1/o_2 .

Part 8 With the +62 mm lens in the SEPTUM slot, and the +120 mm lens in slot 1, the eye focuses on objects about 11 cm from the +120 mm lens. The observed magnification of the image on the retina is about -1.

The distance from the +120 mm lens to the object is 9 cm. The calculated image distance for this lens is -36 cm. The calculated magnification of the virtual image is +4.

Experiment 2: Telescope

With the telescope set up as described, $f_1 = 20$ cm, $o_1 = 51$ cm, and:

$$\frac{1}{i_1} = \frac{1}{20 \text{ cm}} - \frac{1}{51 \text{ cm}}$$

$$i_1 = 32.9 \text{ cm}$$

The distance between the lenses is 42 cm, therefore:

$$o_2 = 42 \text{ cm} - 32.9 \text{ cm} = 9.1 \text{ cm}$$

and:

$$\frac{1}{i_2} = \frac{1}{10 \text{ cm}} - \frac{1}{9.1 \text{ cm}}$$

$$i_2 = 101 \text{ cm}$$

The total magnification of the telescope is

$$M = \left(\frac{32.9 \text{ cm}}{51 \text{ cm}} \right) \left(\frac{-101 \text{ cm}}{9.1 \text{ cm}} \right) = -7.2$$

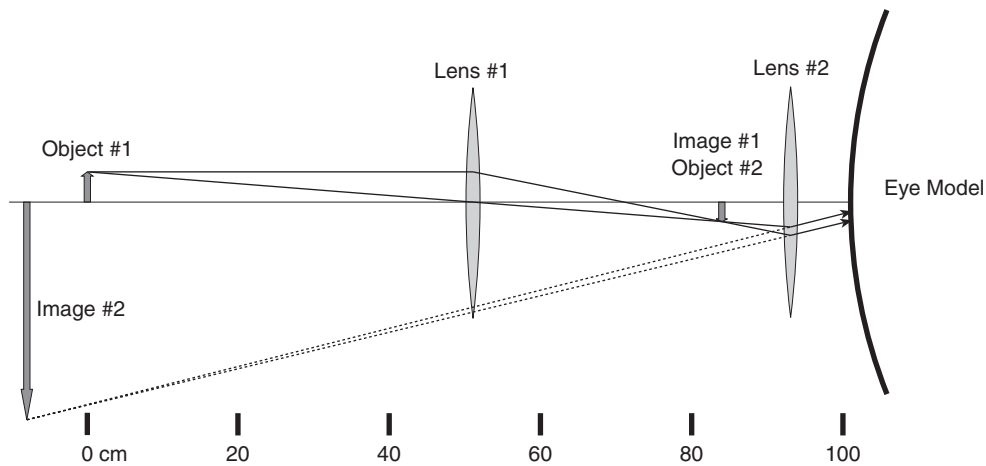

Experiment 3: Refraction, a Detailed Study

The distance of the first image from the curved surface of the corneal lens is

$$i_1 = \frac{n_{\text{glass}}}{n_{\text{glass}} - 1} R_1 = \frac{1.524}{0.524} (7.1 \text{ cm}) = 20.7 \text{ cm}$$

The object distance (o_2) is i_1 minus the thickness of the lens. Also, Image #1 (which becomes Object #2) is formed behind the flat surface, outside of the glass lens, so the object distance is negative. Thus:

$$o_2 = -(20.7 \text{ cm} - 0.40 \text{ cm}) = -20.3 \text{ cm}$$

$$i_2 = \frac{n_{\text{glass}}}{n_{\text{water}}} o_2 = \frac{1.33}{1.524} (-20.3 \text{ cm}) = 17.7 \text{ cm}$$

The object distance (o_3) is i_2 minus the distance from the flat surface on the glass lens out to the center of the crystalline lens. Image #2 (which becomes Object #3) is formed behind the lens, making the object sign negative. Thus:

$$o_3 = -(17.7 \text{ cm} - 2.2 \text{ cm}) = -15.5 \text{ cm}$$

The focal length of the lens *in air* is 12.0 cm, therefore

$$R_3 = \left(\frac{n_{\text{plastic}}}{n_{\text{air}}} - 1 \right) 2f = \left(\frac{1.58}{1} - 1 \right) 2(12.0 \text{ cm}) = 13.9 \text{ cm}$$

The focal length of this lens *in water* is

$$\frac{1}{f'} = \left(\frac{n_{\text{plastic}}}{n_{\text{water}}} - 1 \right) \frac{2}{R_3} = \left(\frac{1.58}{1.33} - 1 \right) \frac{2}{13.9}$$

$$f' = 37.0 \text{ cm}$$

Using these values of object distance and focal length, the image distance is

$$\frac{1}{i_3} = \frac{1}{f'} - \frac{1}{o_3} = \frac{1}{37.0 \text{ cm}} - \frac{1}{-15.5 \text{ cm}}$$

$$i_3 = 10.9 \text{ cm}$$

The distance measured from the handle of the crystalline lens to the handle of the retina screen is 10.5 cm. The curvature of the retina screen adds a few millimeters to make this distance equal to the calculated image distance.

Technical Support

For assistance with any PASCO product, contact PASCO at:

Address: PASCO scientific
10101 Foothills Blvd.
Roseville, CA 95747-7100

Phone: 916-786-3800 (worldwide)
800-772-8700 (U.S.)

Fax: (916) 786-3292

Web: www.pasco.com

Email: support@pasco.com

Limited Warranty

For a description of the product warranty, see the PASCO catalog.

Copyright

The PASCO scientific 012-09304A *Human Eye Model Instruction Manual* is copyrighted with all rights reserved. Permission is granted to non-profit educational institutions for reproduction of any part of this manual, providing the reproductions are used only in their laboratories and classrooms, and are not sold for profit. Reproduction under any other circumstances, without the written consent of PASCO scientific, is prohibited.

Trademarks

PASCO and PASCO scientific are trademarks or registered trademarks of PASCO scientific, in the United States and/or in other countries. All other brands, products, or service names are or may be trademarks or service marks of, and are used to identify, products or services of, their respective owners. For more information visit www.pasco.com/legal.

