

Chemistry MultiMeasure Sensor

PS-2170

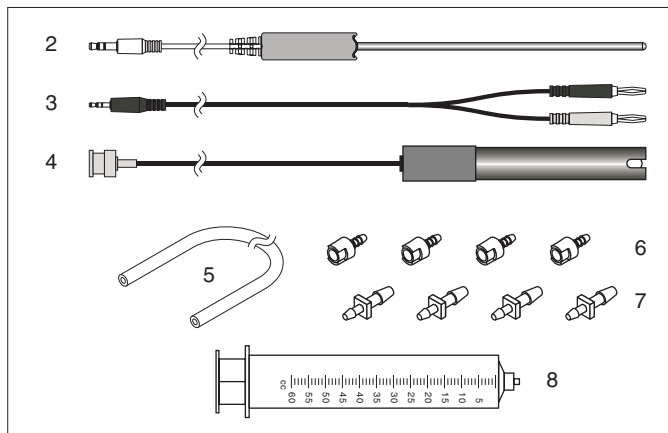
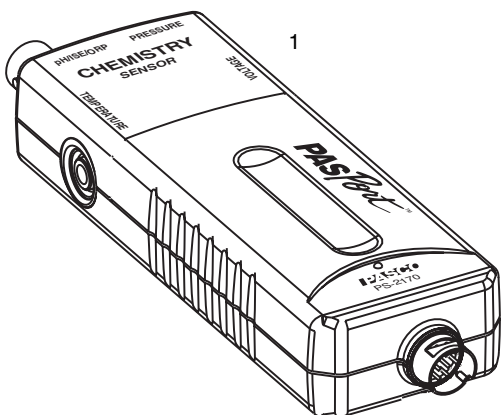

Included Equipment

Included Equipment	Part Number
1. Chemistry MultiMeasure Sensor	PS-2170
2. Stainless Steel Temperature Probe	PS-2153
3. Voltage Probe	PS-2165
4. pH Electrode	699-195
5. Polyurethane Tubing (60 cm long, 1/8 inch ID)	640-023
6. Quick-release Connectors (qty. 4)	640-021
7. Tubing Connectors (qty. 4)	640-030
8. Syringe (60 cc)	699-166

Required Equipment

PASPORT Interface ¹	See PASCO catalog or www.pasco.com
--------------------------------	--

Optional Equipment

Fast-response Temperature Probe	PS-2135 (3-pack)
Skin/surface Temperature Probe	PS-2131
Various Ion-selective Electrodes (ISE)	See PASCO catalog or www.pasco.com
Oxidation Reduction Potential (ORP) Electrode	CI-6716

¹PASPORT interfaces include the AirLink (IW-4100 or PS-2005), Xplorer GLX (PS-2002), Xplorer (PS-2000), PowerLink (PS-2001), and USB Link (PS-2100)

Introduction

The PS-2170 Chemistry MultiMeasure Sensor combines four sensors in a single unit:

- Temperature
- pH, ORP and ion-selective electrode voltage
- Absolute gas pressure
- Voltage

When connected to a PASPORT interface, the multi-sensor collects data at up to 100 samples per second from each component sensor. You can use just one component sensor at a time or any combination simultaneously. If you have a PASPORT interface that supports multiple sensors, or if you have more than one interface connected to your computer, you can use the Chemistry MultiMeasure Sensor in combination with other PASPORT sensors.

Sensor, Interface, and Software Setup

Connect the multi-sensor to your PASPORT interface as pictured (right). Connect any or all of the included probes to the multi-sensor. (You can leave any of the probes disconnected if you do not plan to use it.) If you will be using an ion-selective electrode or oxygen reduction potential electrode, connect it to the pH/ISE/ORP port. If you plan to measure pressure in an apparatus or the included syringe, connect it to the sensor's pressure port using the included tubing and a quick-release connector.

Follow the instructions below to set up the sensor with DataStudio software (if you are using a computer) or the Xplorer GLX (if you are using it stand-alone without a computer).

For detailed information about each of the multi-sensor sensor's component sensors see pages 3–5.

DataStudio Setup

If you are using a computer, connect the PASPORT interface to the computer and start DataStudio. (Refer to the documentation that came with your PASPORT interface for instructions on connecting it to your computer.) In DataStudio, click the Start button to begin data collection; click the Stop button to stop data collection.

Note that the sensor may collect data for probes that are not connected. Hide or ignore these measurements. To hide measurements that you do not need, open the Experiment Setup Window by clicking the Setup button. In the Setup window you can also change the sampling rate and open the calibration dialog box (see Appendix A). For more instructions on using DataStudio, press F1 to open DataStudio's on-line help.

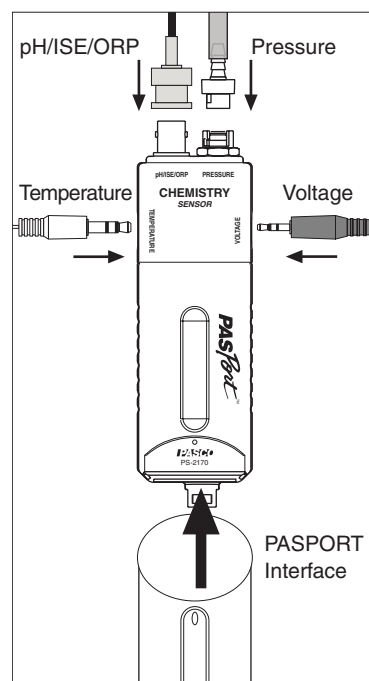

Xplorer GLX Setup

If you are using an Xplorer GLX in standalone mode, press  to start data collection.

Note that the sensor may collect data for probes that are not connected. Hide or ignore these measurements. To hide measurements that you do not need, open the Sensors screen (from the Home screen, press ). In the Sensors screen you can also change the sampling rate and open the calibration dialog box. For more instructions on using the Xplorer GLX, refer to the GLX Users' Guide.

Temperature

Use this component of the multi-sensor to measure the temperature of a fluid or object. The measurement can be displayed in units of °C, °F, or K. (In DataStudio, click the Setup button to change units.) You can use the included stainless steel probe or a different probe, such as the Fast-response Probe (PS-2135) or Skin/Surface Probe (PS-2131). PASCO apparatus containing an embedded 10 k Ω thermistor can also be connected to the multi-sensor. The multi-sensor automatically detects the presence of a temperature probe, and it will only collect temperature data if a probe is connected.

Measuring Temperature

To measure temperature, connect the probe and start data collection. Immerse the tip of the probe in a fluid or place it in contact with an object. The included stainless steel probe can be used in both dry conditions and in liquids, such as water and other mild chemicals and solutions.

Tip: For better chemical resistance, use a Teflon[®] cover (CI-6549).

Temperature Calibration

The temperature measurement can be calibrated; however, for most applications calibration is not necessary. Use a two-point calibration with two standards of known temperature. For instructions on calibrating in DataStudio, see Appendix A. For instructions on calibrating on the Xplorer GLX, refer to the Xplorer GLX Users' Guide.

pH/ISE/ORP

The pH/ISE/ORP input of the multi-sensor is a specialized voltage sensor. Its BNC connector accepts the included pH electrode, as well as ISE and ORP electrodes. The sensor measures the voltage produced by any of these electrodes. When used with a pH probe, the sensor also computes the pH based on the measured voltage.

Connect the pH electrode (or other electrode) to the pH/ISE/ORP port and start data collection. On your computer or interface, display the **ISE Voltage** measurement (this measurement is valid for pH and ORP electrodes as well as ISE) or the **pH** measurement for the calculated pH (assuming that the pH electrode is connected).

Measuring pH

The pH electrode produces a voltage proportional to the pH of the solution that it is immersed in. This voltage is measured by the multi-sensor, which computes pH.

Unscrew and remove the storage bottle from the electrode (be careful not to spill the storage solution). Push the O-ring and bottle cap up the electrode handle. Rinse the electrode tip with distilled water. If you see bubbles in the electrode bulb, gently shake the electrode downward (similar to shaking down a thermometer). Start data collection. Place the tip of the electrode in the solution to be measured and wait for the reading on your computer or interface to stabilize. Rinse the electrode with distilled water before measuring another solution.

pH Calibration

The pH measurement can be calibrated; however, for most applications calibration is not necessary. Perform a two-point calibration with two buffer solutions of known pH. For instructions on calibrating in DataStudio, see Appendix A. For instructions on calibrating on the Xplorer GLX, refer to the Xplorer GLX Users' Guide.

pH Electrode Maintenance and Storage

Cleaning

If the pH electrode becomes contaminated, use one of these methods to clean and restore it. After any of these procedures, soak the electrode in a pH 7 buffer solution for 30 minutes.

- **General Contamination:** Soak the electrode in 0.1 molar hydrochloric acid (HCl) for 15 minutes.
- **Protein Deposits:** Soak the electrode in a solution of 1% pepsin in 0.1 molar HCl.
- **Inorganic Deposits:** Rinse the electrode with 0.1 molar ethylene dinitric tetra-acidic acid (EDTA) tetrasodium solution.
- **Oil and Grease Film:** Wash the electrode carefully in a mild detergent or a solvent known to be effective for the particular film.
- **Unknown Contamination:** Soak the electrode alternately in 12 molar sodium hydroxide (NaOH) and 1 molar HCl. Leave it in each solution for one minute. Rinse completely between soakings. End with HCl. (The NaOH etches the glass and the HCl reestablishes hydrogen ions on the surface.)

If these steps fail to improve the response of the electrode, replaced it.

Storage

Store the pH electrode in the included electrode storage bottle with one of the following solutions. (Never store the electrode in distilled water.)

- **Short-term** (up to one week): pH 4 buffer solution or tap water.
- **Long-term** (over one week): pH 4 buffer solution with 1 g per 100 mL of potassium chloride (KCl) added.

Pressure

This component of the multi-sensor measures absolute gas pressure from 0 kPa to 700 kPa. The measurement can be displayed in units of kPa, N/m^2 , pounds per square inch (p.s.i.), atmospheres (atm), or torr. (In DataStudio, click the Setup button to change units.)

With nothing connected to pressure port, the sensor measures atmospheric pressure.

To measure the pressure in an apparatus or the included syringe, connect it to the sensor using the included tubing and connectors. Insert the barbed end of a quick-release connector into a piece of tubing. Push the quick-release connector onto the sensor's pressure port and twist it clockwise to secure it. If your apparatus has a barbed or tapered connector (such as the included syringe), plug it directly into the other end of the tubing. If the apparatus has a quick-release pressure port, use another quick-release connector on the other end of the tubing. Use one of the included tubing connectors to connect the tubing to larger-diameter tubing or to a rubber stopper with a hole.

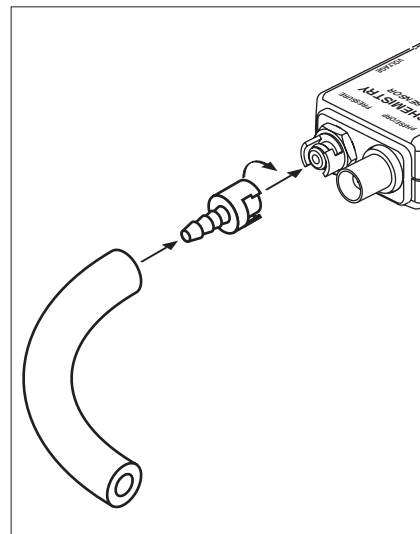

Note: Do not allow liquid to enter the pressure port.

Voltage

Use the voltage component of the multi-sensor to measure electric potential difference between the terminals of a battery or power supply, or two points on a circuit. The voltage probe has two connectors: red and black. The sensor measures the voltage of the red connector in reference to the black connector. Its range is ± 10 V.

Specifications

General	
Component Sensors	Temperature, pH/ISE/ORP probe voltage, Absolute Pressure, Voltage
Max. Sampling Rate	100 samples per second (for each component sensor)
Default Sampling Rate	10 samples per second
Temperature	
Range	-35 °C to +135 °C
Accuracy	±0.5 °C
Resolution	0.01 °C or better
Sensing Element	10 kΩ thermistor located in probe tip
pH/ISE/ORP probe voltage	
Electrode Connector	standard BNC
Voltage Range	-2000 mV to +2000 mV
Voltage Resolution	0.1 mV
pH Range	0 to 14
pH Resolution	0.001
Absolute Pressure	
Range	0 kPa to 700 kPa
Accuracy	2 kPa
Resolution	0.1 kPa
Repeatability	1 kPa
Voltage	
Range	-10 V to + 10 V
Accuracy	± 0.1 V
Resolution	± 0.04 mV
Voltage Protection	up to 240 V
Input Resistance	2 MΩ

Appendix A: DataStudio Calibration

In DataStudio, click the Setup button to open the Experiment Setup window; in that window, click the Calibrate button to open the Calibrate Sensors dialog box. For a two-point calibration, you will need two “known standards,” such as two buffer solutions of known pH or two liquids of known temperature.

1. From the Sensor field, select **Chemistry**.
2. From the Measurement field, select **Temperature or pH**.
3. Ensure that “Calibrate all similar measurements simultaneously” is *not* selected.
4. From the Calibration Type menu, select **2 Point (Adjust Slope and Offset)**, if it is not already selected.
5. Place the temperature or pH probe in the first known standard.
6. Enter the known temperature or pH of the standard in the **Standard Value** field for Point 1.
7. Observe the **Present Sensor Measurement** and wait until it has stabilized.
8. Click the **Read From Sensor** button for Point 1.
9. Place the probe in the second known standard.
10. Enter the known temperature or pH of the standard in the **Standard Value** field for Point 2.
11. Observe the **Present Sensor Measurement** and wait until it has stabilized.
12. Click the **Read From Sensor** button for Point 2.
13. Click **OK** to accept the new calibration.

Appendix B: EZ Screen

If you are using the Chemistry MultiMeasure Sensor with a PASPORT interface connected to a computer, you can use EZ-Screen software instead of DataStudio. When the sensor is connected to the computer through the interface (if DataStudio is not running) a window automatically launches giving you the option of launching EZ-Screen. In EZ-Screen, click the green arrow button to start data collection. Click the Chemistry Sensor icon in the lower-right corner to cycle through the measurements and units.

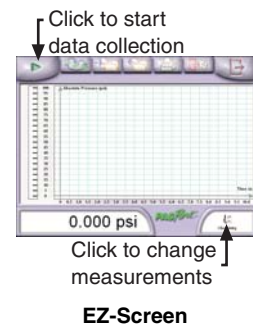

Technical Support

For assistance with any PASCO product, contact PASCO at:

Address: PASCO scientific
10101 Foothills Blvd.
Roseville, CA 95747-7100

Phone: 916-786-3800 (worldwide)
800-772-8700 (U.S.)

Fax: (916) 786-3292

Web: www.pasco.com

Email: support@pasco.com

Limited Warranty

For a description of the product warranty, see the PASCO catalog.

Copyright

The PASCO scientific 012-09456B *Chemistry MultiMeasure Sensor Instruction Manual* is copyrighted with all rights reserved. Permission is granted to non-profit educational institutions for reproduction of any part of this manual, providing the reproductions are used only in their laboratories and classrooms, and are not sold for profit. Reproduction under any other circumstances, without the written consent of PASCO scientific, is prohibited.

Trademarks

PASCO, PASCO scientific, DataStudio, MultiMeasure Sensors, PASPORT, Xplorer and Xplorer GLX are trademarks or registered trademarks of PASCO scientific, in the United States and/or in other countries. All other brands, products, or service names are or may be trademarks or service marks of, and are used to identify, products or services of, their respective owners. For more information visit www.pasco.com/legal. Teflon is a registered trademark of DuPont.