

zu beziehen bei  
sold by  
[www.conatex.com](http://www.conatex.com)

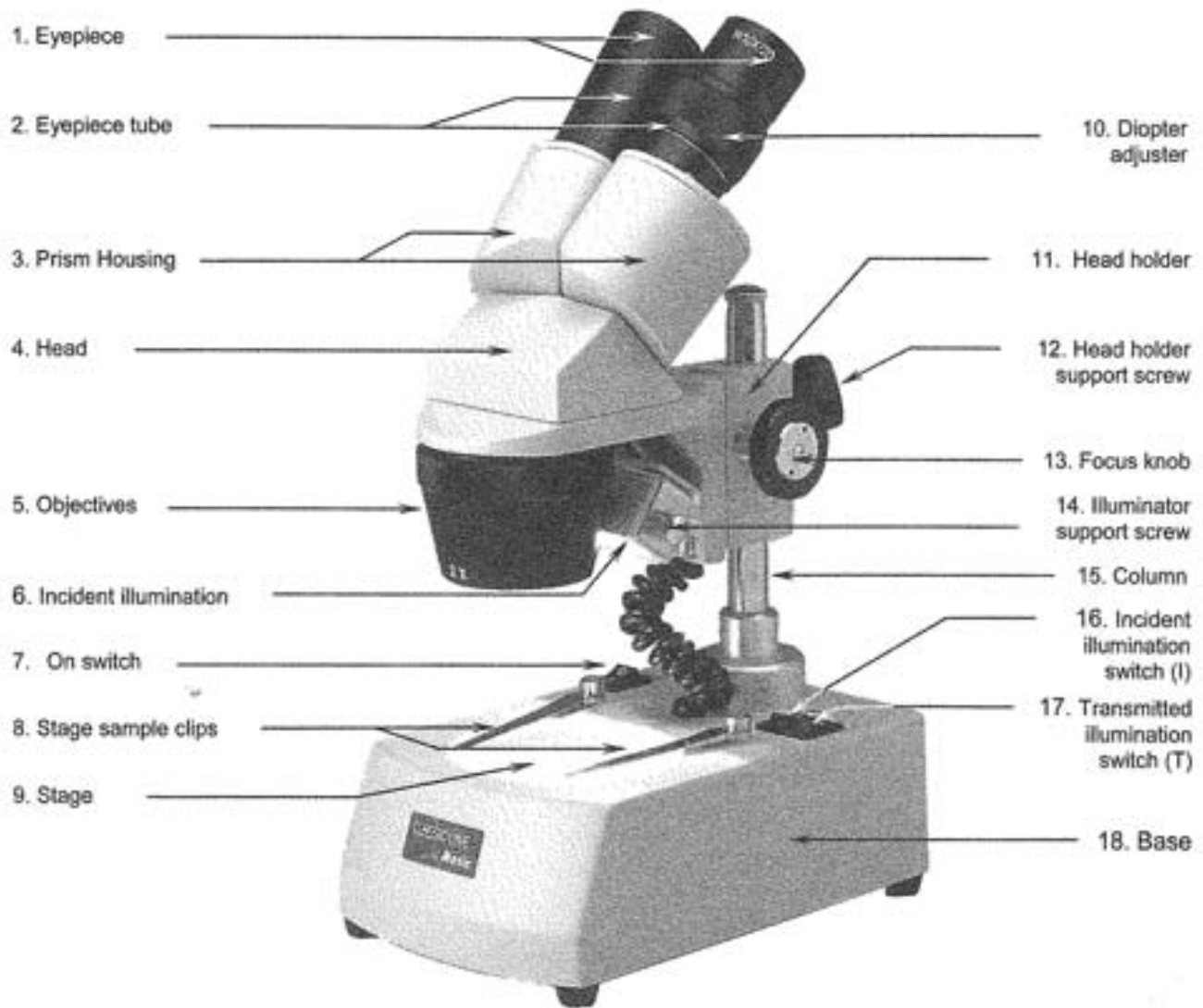

ST-30C-2LOO

## Introduction

Thank you for your purchase of a Motic microscope. Motic microscopes are precision instruments, subjected to meticulous examination to reach you in perfect condition. Their design combines easy management and optimum functioning with minimum maintenance.

The information contained in this manual is likely to go beyond what the average user needs to know to use the stereomicroscope, however, it is provided to answer any queries that may arise.

Stereomicroscopes are used to study three dimensional objects, examine small parts, or dissect biological specimens. They also permit the observation of slide specimens.

These instructions should be read carefully before operating the microscope. They will permit you to use your new stereomicroscope to its fullest capabilities. Terminology used to describe components and controls can be found in the diagram on page 2.

These instructions are based on the assembly and use of the ST-30C-2LOO model, with additional notes applying specifically for the other models in the series. For those models with A objectives, objectives referred to are 1X and 2X (rather than 2X and 4X); whilst for models with B or objectives referred to are 1X and 3X.

## Unpacking

All components of the stereomicroscope have been carefully packed to ensure they reach you in perfect condition. We recommend that you do not discard any packing containers in case you need to return the microscope, store it for long periods of time; or should it become necessary to transport it to a technical service for any repair, or maintenance procedure.

The box should contain the following components:

- ST-30C-P: A base without illumination, a binocular head with mounted eyepieces, a black and white plastic stage, eyepiece protectors, a protective cover and a 2mm hexagonal key.
- ST-30C-LO: A base with incident illumination, a binocular head with mounted eyepieces, a black and white plastic stage, eyepiece protectors, a protective cover and a 2mm hexagonal key.
- ST-30C-2LOO: A base with incident illumination, a binocular head with mounted eyepieces, a black and white plastic stage, a frosted glass stage, eyepiece protectors, a protective cover and a 2mm hexagonal key.
- ST-38C-2LOO: A base with incident and transmitted illumination, a binocular head with mounted eyepieces, a black and white plastic stage, a frosted glass stage, eyepiece protectors, a protective cover and a 2mm hexagonal key.
- ST-37C-2LOO: A base with incident and transmitted illumination, a binocular head with mounted eyepieces, a black and white plastic stage, a frosted glass stage, eyepiece protectors, a protective cover and a 2mm hexagonal key.
- ST-38C-2LTO: A base with incident and transmitted illumination, a trinocular head with mounted eyepieces, a black and white plastic stage, a frosted glass stage, adapters for photography and CCD cameras, eyepiece protectors, a protective cover and a 2mm hexagonal key.

**Remove and handle all components of the microscope with extreme care.**

**Avoid touching the lenses of the optical elements and keep clear of contact with dust, water or other contaminating agents, as they could stain, or damage the lens surface and affect the quality of the image.**

## Description of Components

1. Head (4). Available in binocular or trinocular and rotating 360°, according to the model.
2. Eyepiece (1). The group of lenses closest to the eye, magnifying the image formed by the objectives.
3. Diopter adjustment (10). Permits the user to adjust the focus for different levels of vision.
4. Objectives Turret (5). The revolving action permits the user to change the degree of magnification, the correct positioning of the objectives is marked by a "click" in the optical path.
5. Objectives (5). The group of lenses closest to the sample, or microscopic specimen forming the first magnified image.
6. Stage (9). Platform where the specimen is placed. With holder clips.
7. Focusing Knobs (13). Situated on both sides of the arm of the stereomicroscope, they allow the object to be brought into focus.
8. Illumination (6). Depending on the model, 12V y 10W incident illuminated (Base LO) or incident and transmitted illumination (Base 2LOO).

## Assembly

All the steps described for the assembly of the stereomicroscope must be undertaken with extreme care, and without forcing the placement of the distinct parts and elements of the microscope.

- A. Place the stereomicroscope, on a flat, stable and clean surface.
- B. For all models except ST-30.  
For greater comfort place the head (4) with the eyepiece (1) to face the opposite direction from the arm and column (14).
  1. Loosen the head holder support screw (Fig. 1) and turn the head 180°.
  2. Tighten the head holder support screw.

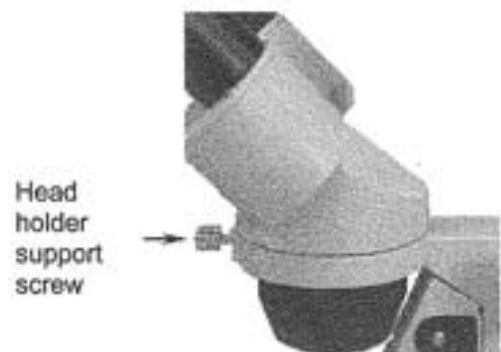

Fig. 1

**Warning:** Before connecting the microscope to an electrical source, always check that the voltage coincides with that of the stereomicroscope.

## Operation

- A. Starting Up.

The stereomicroscope comes with two stage plates. One is frosted for the observation of microscopic specimens slides, or thin, or transparent samples such as leaves or insect wings. The black and white stage plate is used to study opaque objects, or for dissection. The best contrast of a sample would depend on the colour of the stage plate chosen.

1. Changing the stage.

- a. Loosen the locking set screw (Fig. 2) with the key provided, and remove stage (9).
- b. If glass stage is used, place it with the frosted surface facing down.
- c. Tighten locking set screw

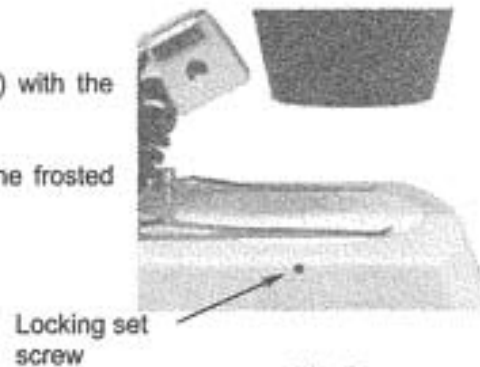

Fig. 2

Depending on the stereomicroscope, there are three types of light switch on the base.

- MAIN : Turns the entire unit on or off.
- I : Turns incident light on or off. (Top illumination)
- T : Turns transmitted light on or off. (Bottom illumination)

2. Press the main switch to position "I" (7).
3. Press the incident or transmitted illumination switch (16-17), or both at once, to position "I" or "II", according to necessities in examining the sample.

B. Interpupillary Adjustment.

1. Whilst looking through both eyepieces (1), move eyepiece tubes (2) on their axis, holding head by the eyepiece tubes housing the prisms. (3).
2. When a full field of view is obtained, and converted into a single image, interpupillary distance is correct for your eyes.
3. Each user must adjust interpupillary distance to match their eyesight

C. Focussing

1. Turn objective turret (5) so that the lowest magnification number 2X is facing the front of the microscope, lined up with the eyepiece, and the 4X magnification is located at the two sides, perpendicular to the eyepiece. The turret permits a 1/4 turn. Make sure that turret is "clicked" into its correct position.  
**NB:** In the ST-37 model, omit steps 2,3 and 4, passing directly to 5.
2. Place a flat object or a slide on center of stage (9).
3. Turn focus knobs (13) to mid range.
4. The head holder (11) is mounted on a column (15), and can be moved up or down to accommodate the size of the sample.
  - a. Support head (4) with one hand without touching any lens.
  - b. Without letting go of the head, loosen the screw supporting the head holder (12).
  - c. While looking through the eyepiece (1), move the head holder up or down until the object appears in focus.

- d. Tighten the head holder support screw.
- e. These steps are not necessary every time the stereomicroscope is used, only when the sample is not in the range of focus.

5. Turn focus knobs (13) until the image is sharp.

#### D. Adjusting the diopter.

On the left eyepiece tube there is a diopter adjustment collar. Its normal position is when the lower part of the collar is aligned with the sign marked on the eyepiece tube.

In the case of differences in eyesight:

With the right eye, look through the right eyepiece (1) and adjust focus.

Now use the left eye to look through the left eyepiece, and adjust the focus by turning the diopter adjuster, on the left hand eyepiece tube, until a detailed image is achieved. Do not adjust the focus with the focus knobs (13).

#### E. Changing magnification.

Turn objective turret (5) so that the highest magnification number 4X is facing the front of the microscope, lined up with the eyepiece, and the 2X magnification at the two sides, perpendicular with the eyepiece. The turret permits a 1/4 turn. Make sure that turret is correctly "clicked" into correct position.

1. Although this stereomicroscope comes parfocussed, the focus has to be adjusted owing to the greater depth of field offered by those objectives of lower magnification. Depth of field is the capacity to focus on distinct points, on distinct levels.
2. Once the image with objectives of higher magnification is brought into focus, it is not necessary to re-focus with those of a lower magnification level.

#### Specification chart:

Objective s	Eyepieces										
	WF5x (optional)		WF10x		WF15x (optional)		WF20x (optional)		Working distance		
	Total magnifi- cation	Field size	Total magnifi- cation	Field size	Total magnifi- cation	Field size	Total magnifi- cation	Field size	Binocular	Trinocular	
A	1x	5x	22 mm	10x	20 mm	15x	13 mm	20x	9,5 mm	95 mm	95 mm
	2x	10x	11 mm	20x	10 mm	30x	6,5 mm	40x	4,8 mm		
B	1x	5x	22 mm	10x	20 mm	15x	13 mm	20x	9,5 mm	94 mm	80 mm
	3x	15x	7,3 mm	30x	6,7 mm	45x	4,3 mm	60x	4,3 mm		
C	2x	10x	11 mm	20x	10 mm	30x	6,5 mm	40x	4,8 mm	94 mm	80 mm
	4x	20x	5,5 mm	40x	5 mm	60x	3,3 mm	80x	3,3 mm		

#### Adapting a photographic, or a video camera (only for model ST-38).

The model ST-38 comes equipped with a vertical image port on the head which permits the installation of photographic reflex camera, or a video camera, using the corresponding adapters (Fig.3). The vertical port is used to capture the image through the objective that is not being used, so when we observe through the binocular with a 2X magnification, the camera receives images through the 4X objective.

To adapt a photographic camera, an adapter tube is needed. This tube includes 2X lenses for photography that measure the correct parfocality between the images coming through the binocular and vertical ports. This balance can be achieved providing that the parfocality has been adjusted correctly, as described in point "D. Changing magnification" in this manual.

The adapter tube has a T type thread where adapter mounts of all types can be adapted for all reflex camera brand names on the market.

**NB:** The T thread is not included as it depends on the camera brand.

1. To connect the camera to the microscope, first remove the front lens of the camera, and place the corresponding T mount. Screw on the adapter tube provided, onto the mount of the camera.



Fig. 3

2. Loosen the knurled screw (Fig.4), situated on the side of the vertical port on the head, sufficiently enough to remove the protective cover.
3. Insert the adapter tube in the vertical exit. If it does not fit easily, unscrew the knurled screw until the adapter tube fits in perfectly.
4. Tighten knurled screw firmly to support the camera.
5. Operate the camera according to manufacturers instructions.

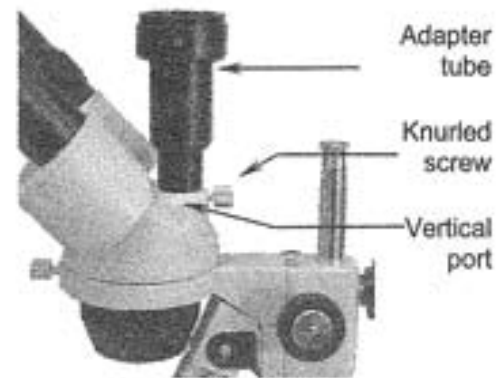

Fig. 4

- A. To adapt a video camera an adapter tube is needed This adapter tube includes 0.5X lenses that correct the parfocality of images, from both binocular and vertical ports, shown on the TV monitor. This is providing that parfocality has been correctly adjusted according to the steps followed in point "D. Changing magnification" in this manual. The adapter tube is provided with a "C" thread, and a "CS" ring which can adapt different kinds of video camera.

To connect the camera to the microscope, screw the adapter tube to the video camera.

1. Loosen the knurled screw (Fig.4) on the side of the vertical port of the head sufficiently enough to remove the protective cover.
2. Insert the adapter tube with the camera already mounted on the vertical port, if it does not insert easily, unscrew the knurled screw until the adapter tube fits perfectly.
3. Re-tighten the knurled screw firmly, so that the camera is secure.
4. Operate the camera according to manufacturers instructions.

If the image on the monitor appears out of focus when the objective is changed, it is possible that the CS mount is responsible. Place, or remove it, according to the procedure to obtain parfocality.

## Maintenance

**WARNING:** FOR YOUR OWN SAFETY SWITCH OFF AND DISCONNECT THE MICROSCOPE FROM ANY ELECTRICAL SOURCE BEFORE ATTEMPTING ANY MAINTENANCE PROCEDURE TO AVOID THE RISK OF ELECTROCUTION.

CONSULT YOUR DISTRIBUTOR IF ANY REPAIR, OR MAINTENANCE PROCEDURE IS REQUIRED TO YOUR MICROSCOPE THAT DOES NOT APPEAR IN THIS INSTRUCTION MANUAL.

### A. Optical maintenance.

Do not attempt to disassemble any optical component. For any repair work not specified in this manual, consult the technical service responsible in your area.

Before cleaning the lens surface, remove dust with a brush specifically for lenses, or with low pressure compressed air, found in any photography shop.

#### 1. Cleaning the eyepiece.

- a. Do not remove the eyepiece (1) from the eyepiece tube (3).
- b. Clean the external surface, dampening the lens with breath.
- c. Afterwards, dry the lens with special lens paper. Dry in circular movements from the centre of the lens, outwards. Do not wipe the lens when already dry, as they scratch easily.

#### 2. Cleaning the objectives.

- a. Do not remove objectives from the microscope.
- b. Only clean the surface area. Use a soft cotton cloth dampened slightly with Xylene. Dry the lens afterwards with the same cloth.

### B. Electrical Maintenance (Except ST-30P).

#### 1. Changing the transmitted illumination bulb. (Except ST-30-LO)

- a. Loosen the stage fixing screw (Fig. 2) with the key provided, and remove the stage (9).
- b. Remove the bulb carefully, pulling it straight out of the socket.
- c. Place the replacement bulb in the socket.
- d. If the bulb has been touched with the hands it should be immediately cleaned as this could affect light transmission, and the duration of the bulb.
- e. Replace the stage and tighten the screw.

#### 2. Changing incident illumination bulb.

- For all models except the ST-38.
  - a. Unscrew the illuminator protector tube (14), turning it anti-clockwise, and removing the tube from that of the lenses.
  - b. With a cloth carefully pull out the bulb to disconnect it from the socket.
  - c. Insert replacement bulb in socket.

- d. If the bulb has been touched with the hands, clean it as this could affect light transmission, or the duration of the bulb.
  - e. Replace the bulb cover and tighten the screw.
- For model ST-38.
    - a. Unscrew the bulb protector tube, turning it anti-clockwise.
    - b. Carefully take hold of the bulb, press down towards the socket, and turn 1/4 turn in an anti-clockwise direction. Release pressure and the bulb can be removed from the socket.
    - c. Insert the replacement bulb, pressing towards socket and turn 1/4 turn clockwise.
    - d. Clean the bulb of any fingerprints, as this could affect the transmission of light and the duration of the bulb.
    - e. Replace the bulb protector tube, turning it in a clockwise direction.

### 3. Changing the fuse.

- a. With a flat screwdriver, press lightly on the slot of the fuse cap (Fig. 5) and turn 1/4 turn as indicated by the arrow.
- b. Release pressure and the fuse cap should be loose. Extract it completely.
- c. Remove the fuse in the cap, and insert the new one. Make sure that it is 0.5 Amps.
- d. Replace the cap with the fuse.
- e. Repeat step (a.) but turn 1/4 turn in the opposite direction to that indicated by the arrow. The cap should be closed firmly.

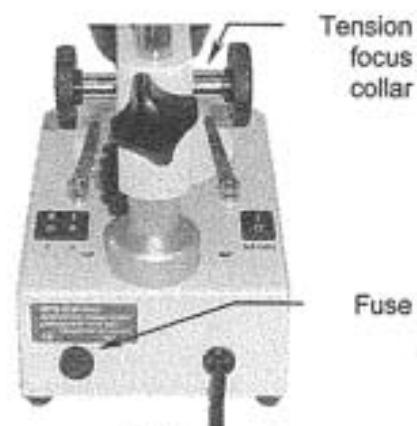

Fig. 5

## C. Mechanical Maintenance

### 1. Adjusting the tension of the focus.

Tension comes pre-adjusted by the factory. The best point of tension is that which permits the focus knobs to move as loosely as possible, without the head sliding down with its own weight.

The tension adjustment collar for focussing (Fig.5) is situated between the focussing knob (13) and the head holder (11).

**NB:** In the model ST-37, the tension adjustment collar can be found between the focus knob (13) and the arm (15).

- a. Loosen the screw located in the collar hole with the 2mm hexagonal key.
- b. To increase the tension, turn the collar anti-clockwise; to decrease it, turn the collar clockwise.
- c. Re-tighten the hexagonal key.



**Troubleshooting:**

**ELECTRICAL PROBLEMS**

PROBLEM	CAUSE	SOLUTION
The bulb does not work.	Outlet inoperative. Cable not connected. Bulb burned out. Fuse blown. Wrong Bulb.	Have it repaired by a qualified specialised technician. Connect the cable to the power source. Replace bulb. Replace fuse. Replace with appropriate bulb.
Bulb burns out immediately.	Wrong bulb.	Replace with the appropriate bulb.
Bulb flickers.	The bulb is not inserted correctly into socket. Bulb on the point of burning out. Fuse cover badly closed. Bad connection with power source.	Insert bulb correctly. Replace bulb. Close correctly. Have repaired by a qualified specialised technician.
Fuse blown quickly	Wrong fuse.	Replace with appropriate fuse.
Fuse blown instantly	Short circuit.	Have repaired by a qualified specialised technician.

**IMAGE QUALITY**

PROBLEM	CAUSE	SOLUTION
No image.	Objectives turret badly positioned.	Adjust, until it "clicks" into place.
Poor resolution.	Eyepieces dirty. Objectives dirty.	Clean eyepieces. Clean objectives.
Spots, or stains in field of view.	Eyepieces dirty.	Clean eyepieces.

\* NB. Stains in field of view may also be attributed to dirt on the inside of the eyepiece. It is recommended therefore that the lens be cleaned by a recognised service technician.

**MECHANICAL PROBLEMS**

PROBLEM	CAUSE	SOLUTION
It does not stay in focus.	The head drops down.	Adjust the tension of the coarse focus knob.

### Moving the microscope

- If possible, avoid moving the stereomicroscope.
- Carry the stereomicroscope in both hands. One hand should hold the stereomicroscope column (15), and the other should support it under the base (18).
- Maintain the stereomicroscope in a vertical position.

### Repair

If the stereomicroscope needs repairing, or revision by authorised personnel, we would recommend that it be stored in its polystyrene box and returned to the distributor. Attach a note with a description of the problem, or details of the required revision.

### Warranty

All MOTIC microscopes are warranted against any manufacturing defect for a 5 year period. Damage occurring by any unauthorised repair work, or occurring through misuse or modification of the microscope will not be included under the conditions of the warranty. Bulbs and fuses are not under warranty.

The warranty service is provided by MOTIC, or its authorised distributors. Defective products will be repaired without charge when returned to MOTIC, or one of its distributors. Transport costs will be covered by the purchaser.

**OWING TO POSSIBLE MODIFICATIONS AND IMPROVEMENTS IN THEIR MANUFACTURE, CHANGES MAY OCCUR TO STEREOMICROSCOPES WITHOUT PRIOR NOTICE.**