

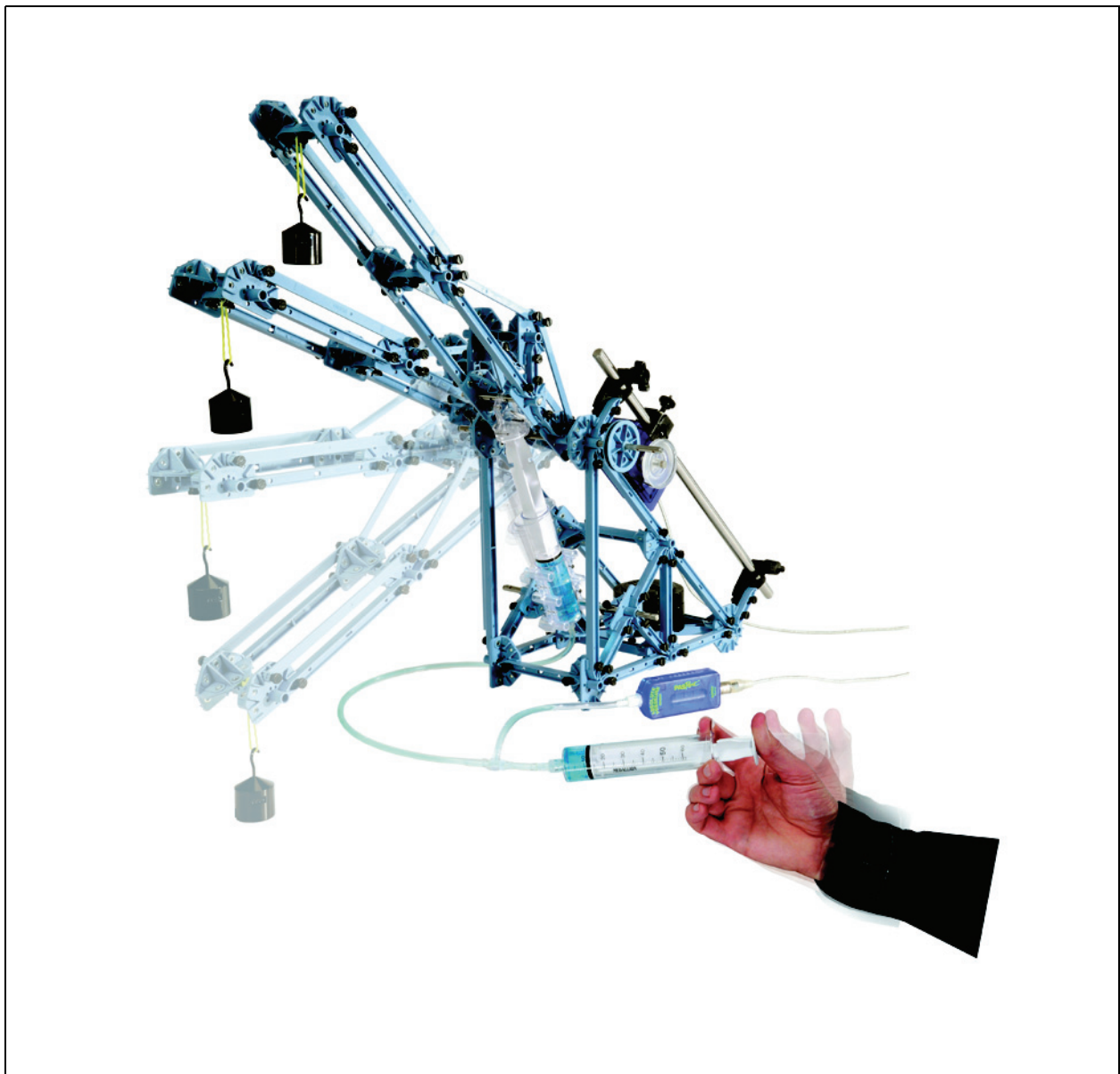

# Hydraulics Structures Set

## ME-6984



The cover page shows the ME-6984 Hydraulics Structures model of a hydraulic boom. Pressurized fluid moves from the syringe to the hydraulic cylinder. As the piston moves out of the cylinder, it lifts the boom structure.

## Table of Contents

|  |    |
|--|----|
| Included Items . . . . .                                     | 1  |
| Related, Required and Recommended Equipment . . . . .        | 2  |
| Introduction . . . . .                                       | 2  |
| Theory . . . . .   | 3  |
| About the Components . . . . .                               | 3  |
| Operation . . . . .  | 4  |
| Adding Load Cells . . . . .                                  | 6  |
| Hydraulic Boom . . . . .                                     | 7  |
| Fork Lift . . . . .  | 9  |
| Scissors Lift . . . . .                                      | 11 |
| Ideal Gas Law . . . . .                                      | 12 |
| Spares Part Numbers and Summary of Extra Equipment . . . . . | 14 |
| Technical Support, Warranty, and Copyright. . . . .          | 15 |



# Hydraulics Structures Set

ME-6984

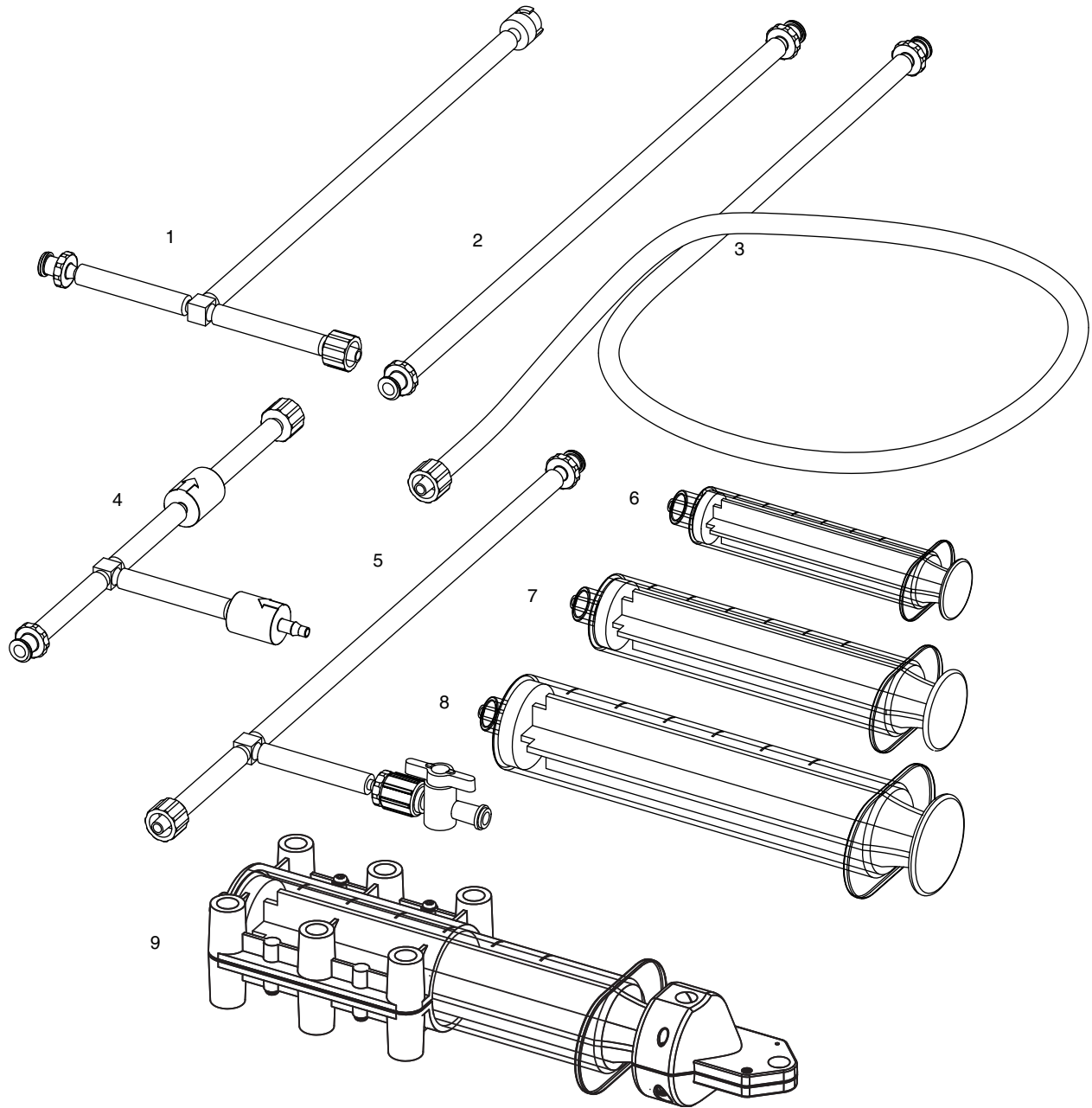

| Included Items             | Included Items                |
|----------------------------|-------------------------------|
| 1. Pressure Sensor Coupler | 6. 10 mL Syringe              |
| 2. Syringe Coupler         | 7. 20 mL Syringe              |
| 3. Extension Tubing        | 8. 60 mL Syringe              |
| 4. Check Valve             | 9. Hydraulic Cylinder         |
| 5. Bleeder Valve           | O-ring Drive Belt (not shown) |

The ME-6984 Hydraulics Structures Set is designed to be used with parts from the PASCO Structures System\*.

|                                |                                  |
|--------------------------------|----------------------------------|
| ME-6985 Flexible I-Beams       | ME-6992A Advanced Structures Set |
| ME-6987 Flat Beams             | ME-6993 Truss Set Members        |
| ME-6989 Physics Structures Set | ME-6997 Full Round Connectors    |
| ME-6990 Truss Set              | ME-6999A Angle Connectors        |
| ME-6991 Bridge Set             | ME-7009 Cast Beam Structures Set |

\*See the PASCO catalog or Web site at [www.pasco.com](http://www.pasco.com) for information about the PASCO Structures System.

The following PASCO equipment is required for the structures shown in this manual..

| Required Equipment               | Required Equipment                  |
|----------------------------------|-------------------------------------|
| ME-6992A Advanced Structures Set | PS-2146 Pressure/Temperature Sensor |
| ME-8736 45-cm Steel Rod          | TD-8596A Ideal Gas Law Syringe      |
| PS-2107 Absolute Pressure Sensor | PASPORT Interfaces*                 |
| PS-2120 Rotary Motion Sensor     | Data Acquisition Software*          |

\*See the PASCO catalog or Web site at [www.pasco.com](http://www.pasco.com) for more information about interfaces and software.

| Recommended Equipment     | Recommended Equipment                       |
|---------------------------|---|
| Hooked Mass Set (SE-8759) | Large Slotted Mass Set (ME-7566 or ME-7489) |

## Introduction

Use the ME-6984 Hydraulics Structures Set with members of the PASCO Advanced Structures Set to build models that move and do work. Build a fork lift, scissors lift, or hydraulic boom. Use sensors to measure the pressure and temperature of the gas or liquid in the hydraulic system, and use a sensor to measure the amount of movement of a structure as the hydraulic system does work.

**Advanced Structures Set (ME-6992A)** - This set contains structure members (see the table) for building cranes, bridges, cars, catapults, and other models.

| Included Items             | Qty | Included Items             | Qty | Included Items       | Qty    |
|----------------------------|-----|----------------------------|-----|----------------------|--------|
| #5 Beam (24 cm long)       | 24  | Flat 2 X 3 Beam (12.5 cm)  | 16  | "O" Ring             | 12     |
| #4 Beam (17 cm long)       | 54  | Flat Round Connector       | 6   | Pulley               | 12     |
| #3 Beam (11.5 cm long)     | 54  | Full Round Connector       | 6   | Collet               | 24     |
| #2 Beam (8 cm long)        | 24  | Half Round Connector       | 42  | Spacer               | 12     |
| #1 Beam (5.5 cm long)      | 24  | Axle (2 each of 3 lengths) | 6   | Sliding Connector    | 12     |
| #3 Flexible Beam (11.5 cm) | 16  | Drive Wheel and Tire       | 4   | Angle Connector      | 24     |
| #4 Flexible Beam (17 cm)   | 16  | Straight Connector         | 24  | Cord Tensioning Clip | 32     |
| #5 Flexible Beam (24 cm)   | 16  | Structures Rod Clamp       | 2   | Yellow Cord          | 1 roll |
| Flat 3 X 4 Beam (19 cm)    | 16  | PAstrack Connector         | 6   | Storage box          | 1      |
| Flat #4 Beam (17 cm)       | 16  | Screw (6-32)               | 300 |                      |        |

## Theory

Hydraulics is a topic in applied science and engineering that deals with the mechanical properties of liquids. Pneumatics is a topic that deals with the study and application of the use of pressurized gas to affect mechanical motion.

Blaise Pascal described the behavior of a fluid (gas or liquid) in a closed container. Pressure applied to an enclosed fluid is transmitted undiminished to every part of the fluid, as well as to the walls of the container. A hydraulic lift is an example of a device that demonstrates the principle. A model of a hydraulic (or pneumatic) lift consists of a syringe that has a large diameter piston connected to another syringe that has a small diameter piston. The pressure is the ratio of force to area and will be the same throughout the system. For example, if the large diameter piston has an area five times larger than the small diameter piston, the hydraulic lift will have a theoretical mechanical advantage of five to one. In other words, a force of 10 N applied to push the small piston into the syringe would cause a force of 50 N to be applied to push the large piston out of the piston. The large piston does the same amount of work as is done to the small piston. The distance that the small piston is pushed into the small syringe is five times more than the distance that the large piston will move out of the large syringe.

## About the Components

### Syringes

The set has three sizes of syringes (60 mL, 20 mL, and 10 mL), each with a male luer (pronounced “loo-er”) lock at one end. The luer lock allows the syringe to be connected to couplers (tubing) or valves. There is a retainer ring on the inside of the large end of the cylinder that helps prevent the piston from being pulled out of the cylinder too easily.

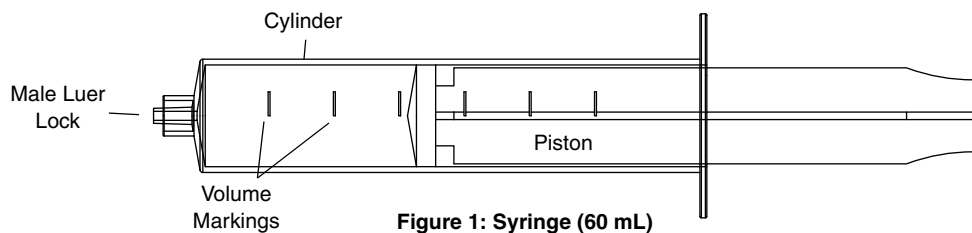

Figure 1: Syringe (60 mL)

### Hydraulic Cylinder

The hydraulic cylinder is a modified 60 mL syringe with six trunnions (cylindrical protrusions used as a mounting or pivot point) on the cylinder and two mounting holes on the end of the syringe. The holes allow the hydraulic cylinder to be mounted between two axles. When the hydraulic cylinder is attached to a structure and a gas (such as air) or a liquid (such as water) is pumped into the cylinder, the pressurized fluid will cause the piston to be pushed out of the cylinder. The part of the structure that the piston is attached to will move.

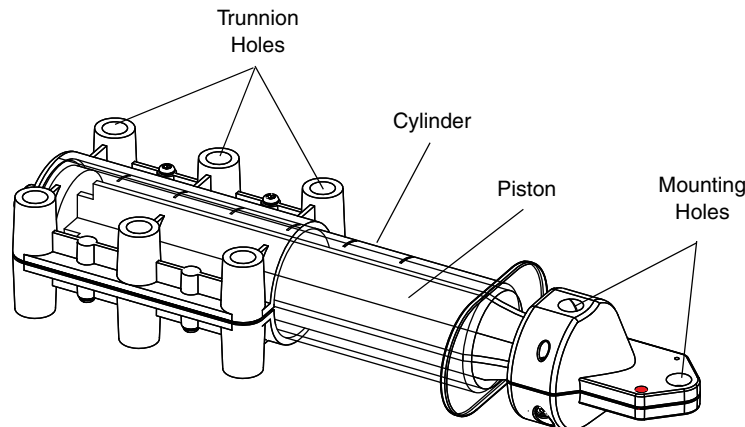

Figure 2: Hydraulic Cylinder

## Couplers

### Pressure Sensor Coupler

The pressure sensor coupler has a “T” shape. The shorter arms of the “T” have a male luer lock at one end and a female luer lock at the other. The longer arm of the “T” has an inline quick connector at the end for connecting to the pressure port on a pressure sensor. Push the inline quick connector onto the pressure port, and turn the quick connector clockwise (left to right) until the connector locks in place.

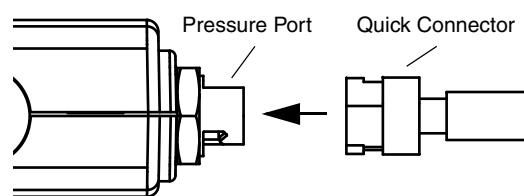

Figure 3: Connector onto Pressure Port

### Syringe Coupler

The syringe coupler is a length of tubing about 27 cm long with a female luer lock at each end. For example, the coupler connects one syringe to another, or a syringe to the hydraulic cylinder. The syringe coupler can also connect to the other couplers and to the valves. The female luer lock screws into a threaded male luer lock.

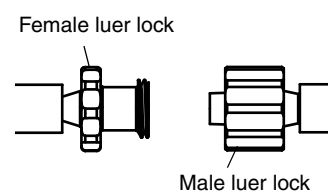

Figure 4: Luer Locks

### Extension Tubing

The extension tubing is about 60 cm long with a female luer lock at one end and a male luer lock at the other. It can be used to increase the distance between components of the hydraulics structures set.

## Valves

### Bleeder Valve

The bleeder valve has a stopcock that can be opened and closed to allow fluid to flow through the valve or not. When the stopcock handle is perpendicular to the tubing, the valve is closed. When the stopcock handle is parallel to the tubing, the valve is open.

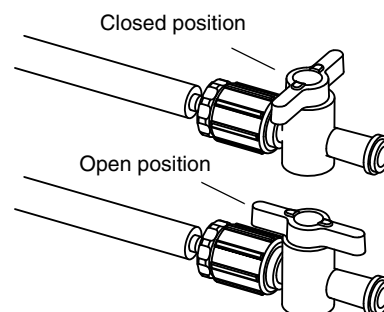

Figure 5: Bleeder Valve

### Check Valve Assembly

The check valve assembly is a “T” shaped assembly that has two one-way valves that allow fluid to flow through the valve in specific directions. For example, when the check valve assembly is connected to a syringe, fluid can flow into the cylinder of the syringe through valve A when the piston is pulled out. When the piston is pushed in, fluid can flow out of the cylinder through valve B. The arrow on each valve indicates the direction that fluid may flow through the valve.

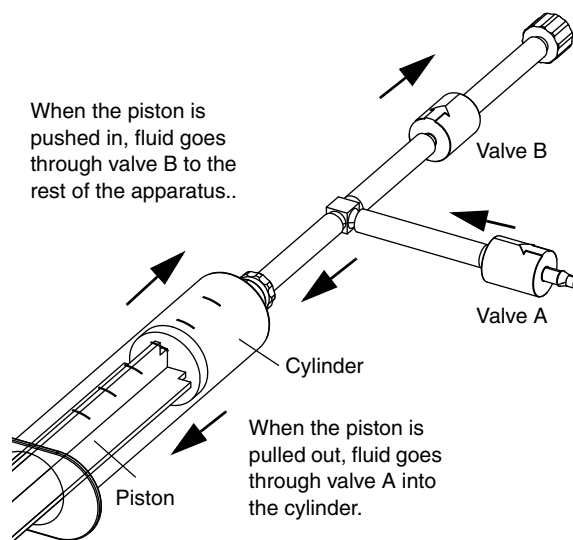

Figure 6: Check Valve Assembly

### O-Ring Drive Belt

The included O-ring can be used as a ‘drive belt’ when it is looped from one pulley to another pulley, or from a pulley to a Rotary Motion Sensor.

## Operation

To demonstrate Pascal’s Principle as described in the Theory section, connect the 60 mL syringe to the syringe coupler. Pull the piston halfway out. Get a 20 mL syringe and pull its piston halfway out. Connect the smaller syringe to the syringe coupler. Have one person hold the 60 mL syringe and another person hold the 20 mL syringe. Have each person push in the piston of their syringe. You should notice that it is much harder to push on



the piston of the smaller syringe than it is to push on the piston of the larger syringe. Can you push the 20 mL syringe's piston all the way in? If so, can you push the 60 mL syringe's piston all the way in while holding the 20 mL syringe's piston in place?

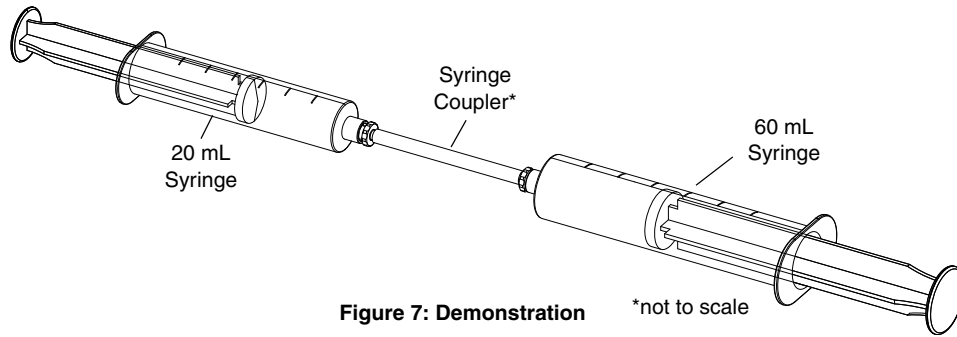

**Figure 7: Demonstration** \*not to scale

To find out how the various components work together, set up the following combination of parts: 20 mL syringe, check valve, bleeder valve, syringe coupler, and hydraulic cylinder. Start with the pistons of both the hydraulic cylinder and the 20 mL syringe pushed all the way in.

- Connect the check valve assembly to the 20 mL syringe.
- Connect the bleeder valve to the check valve assembly.
- Connect the syringe coupler from the bleeder valve to the male luer lock on the hydraulic cylinder.

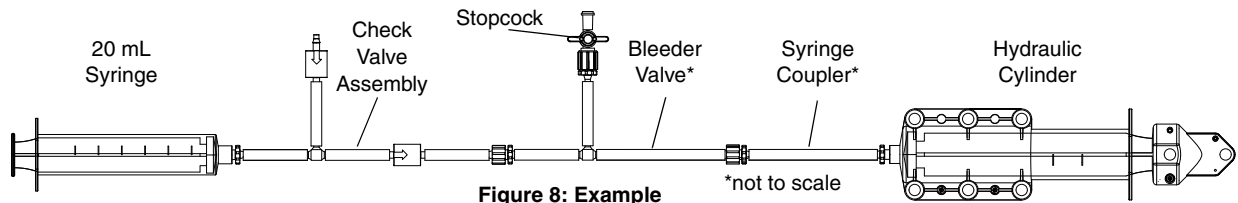

**Figure 8: Example** \*not to scale

- Twist the handle on the stopcock of the bleeder valve to the closed position.
- Pull out the piston of the 20 mL syringe until the tip of the piston is at the 20 mL mark on the syringe.
- Next, push the piston of the syringe all the way in. What happens to the hydraulic cylinder? You should have noticed that the piston of the hydraulic cylinder moved out until the tip of the piston was close to the 20 mL mark on the cylinder. Try it again.
- Pull the piston of the 20 mL syringe so the piston is next to the 20 mL mark. Did the piston of the hydraulic cylinder go back into the cylinder as you pulled the piston out of the syringe? The piston of the hydraulic cylinder should not have moved because the check valve assembly only allows fluid to flow in specific directions. Next, push the piston of the syringe all the way in. The piston of the hydraulic cylinder should move to the 40 mL mark (approximately).
- Repeat the procedure a third time and see whether the piston in the hydraulic cylinder was able to move to the 60 mL mark.

To empty the hydraulic cylinder without disconnecting any tubing, twist the handle of the stopcock to the open position and push the piston of the hydraulic cylinder all the way in. Fluid can flow out of the bleeder valve, but cannot go back into the cylinder of the 20 mL syringe because of the one-way check valve.

## Using a Liquid Instead of a Gas

Fill a syringe with a liquid. Connect the syringe to the syringe coupler. Push the piston slowly to force liquid from the syringe into the syringe coupler until all the air is pushed out of the coupler. Finally, connect a second syringe (or the hydraulic cylinder) with the piston all the way in to the liquid filled syringe coupler. When you push on the piston of the liquid filled syringe, the liquid will push against the piston of the second syringe (or cylinder).

**CAUTION:** If you use the Pressure Sensor Coupler and a pressure sensor in your hydraulics structure, be sure that no liquid enters the pressure port of the sensor. Liquid can go partway into the tubing of the Pressure Sensor Coupler where it connects to the sensor, but leave an air space in the tubing between the liquid and the sensor.

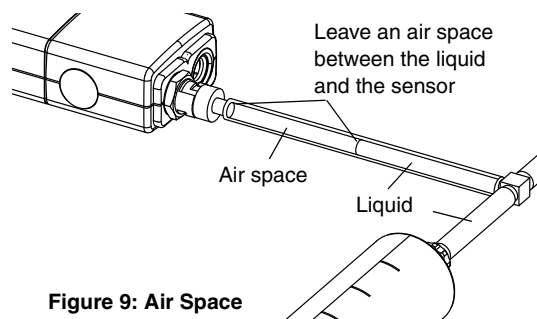

Figure 9: Air Space

## Using a Rotary Motion Sensor to Measure Volume

You can mount a Rotary Motion Sensor (PS-2120) on a rod and attach the rod to your hydraulics structure using Structures Rod Clamps\* (ME-6986). Please see the illustration of the Hydraulic Boom on page 8. Use a thumb-screw to secure a Drive Wheel\* to an axle that will turn when a part of the structure moves. Arrange the sensor and drive wheel so that the included O-ring will fit over the drive wheel and the largest pulley on the sensor.

\*Included in the Advanced Structures Set.

Use the data acquisition software to calibrate the Rotary Motion Sensor. Set the structure so that the volume in the hydraulic cylinder is zero. In the software, set the corresponding position of the Rotary Motion Sensor to be 0 mL (zero milliliters). Move the structure so that the volume in the hydraulic cylinder is at its maximum. Set the corresponding position of the Rotary Motion Sensor to be the maximum volume (e.g., 60 mL).

## Adding Load Cells

To measure the compression and tension forces in individual members of a structure, add load cells (e.g., PASCO Model PS-2200 or PS-2201) to any PASCO Structure. Replace a beam with two shorter beams and a load cell.

#5 beam = load cell + two #3 beams

#4 beam = load cell + two #2 beams

#3 beam = load cell + two #1 beams

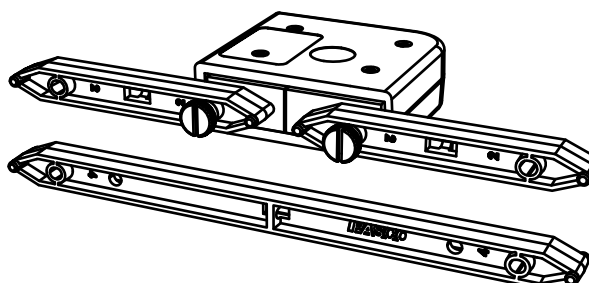

Figure 10: A load cell combined with two #2 beams is the same length as a #4 beam

Use thumbscrews to attach two beams to a load cell as shown in the figure.

*When using load cells, assemble your structure with the screws loose.* This will simplify the analysis by ensuring that the members experience only tension and compression without moments.

### Calibration

See the instructions that came with the load cells for details about how to connect the load cells to an interface or datalogger. Follow the instructions to calibrate the load cells and use them to collect data. (Load cells are factory calibrated; however, you can re-calibrate them in software or on the datalogger. See the documentation for your software or datalogger for instructions.)

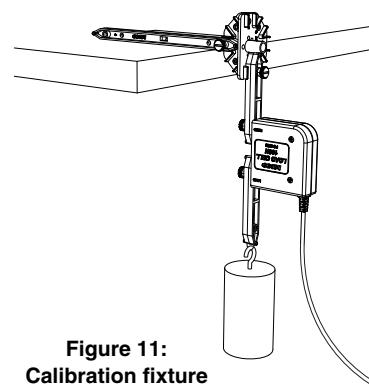
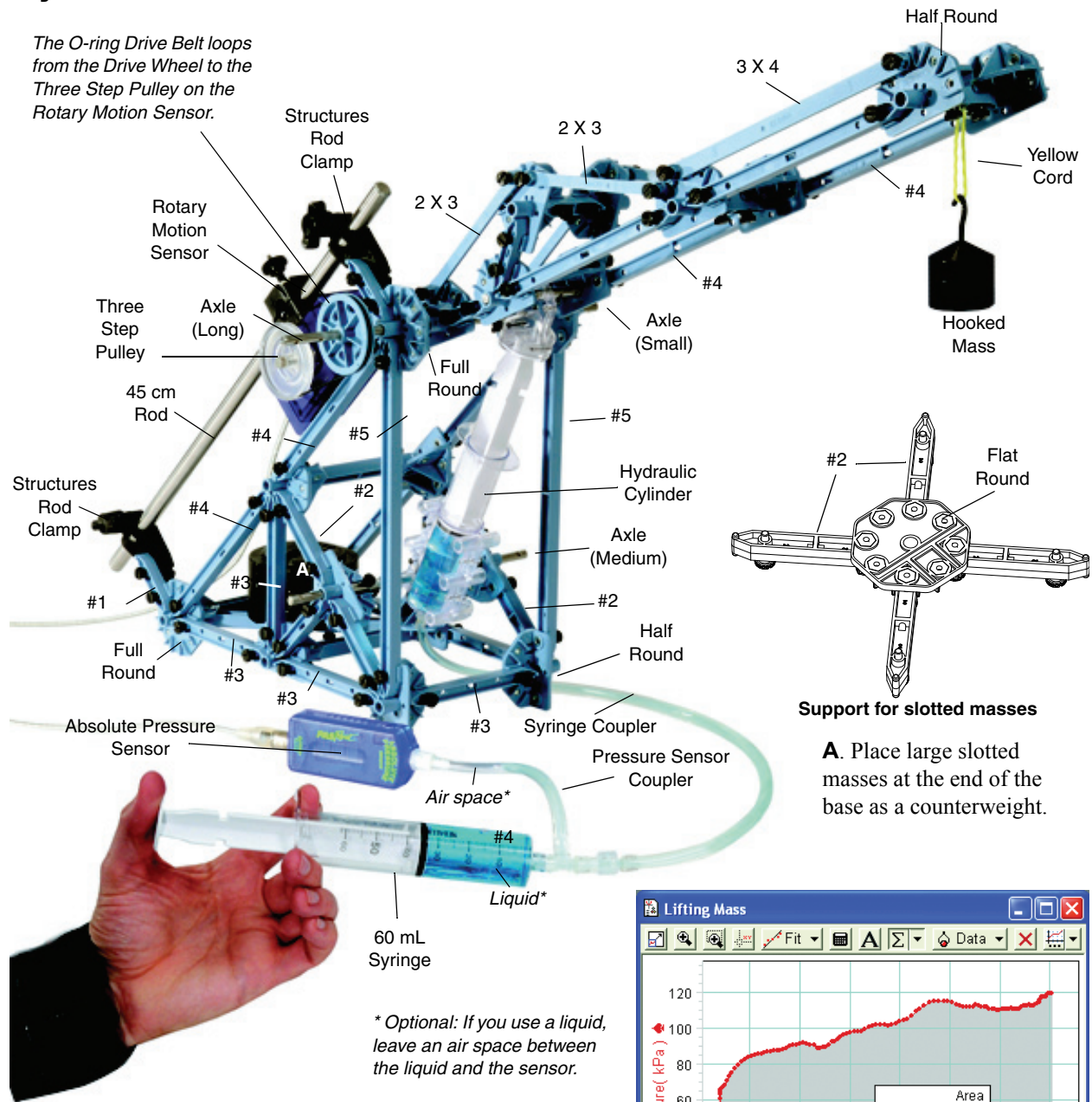

Figure 11: Calibration fixture

# Hydraulic Boom

The O-ring Drive Belt loops from the Drive Wheel to the Three Step Pulley on the Rotary Motion Sensor.



\* Optional: If you use a liquid, leave an air space between the liquid and the sensor.

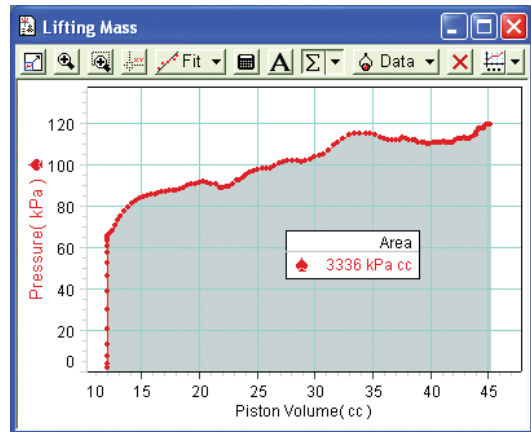

- Use the sensors to measure pressure and volume as the hooked mass is lifted. The work done is the area under the curve.

| Extra Equipment          | Model              |
|--------------------------|--------------------|
| Structures Rod Clamp     | ME-6986            |
| 45-cm Steel Rod          | ME-8736            |
| Hooked Mass Set          | SE-8759            |
| Large Slotted Mass Set   | ME-7566 or ME-7489 |
| Rotary Motion Sensor     | PS-2120            |
| Absolute Pressure Sensor | PS-2108            |
| PASPORT Interface        | see catalog        |

# Hydraulic Boom Details

- Put the medium axle through a trunion hole on the hydraulic cylinder.
- Use collets and thumbscrews on both sides of the hydraulic cylinder to position the cylinder at the middle of the axle.
- Use thumbscrews to attach the medium axle to the half round connectors.

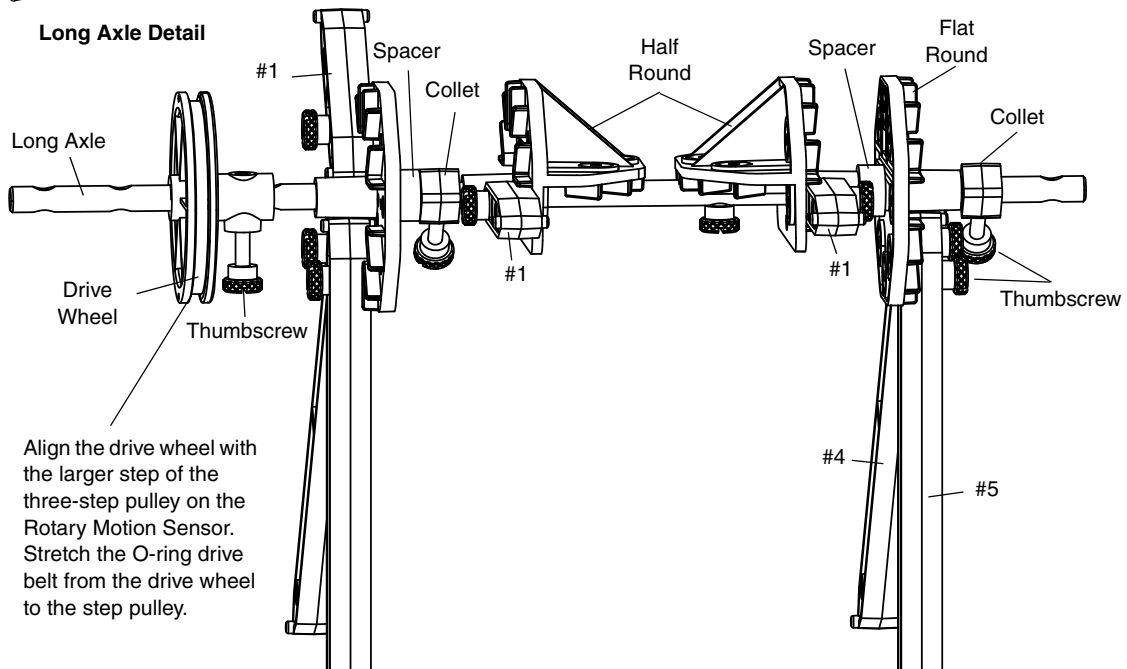
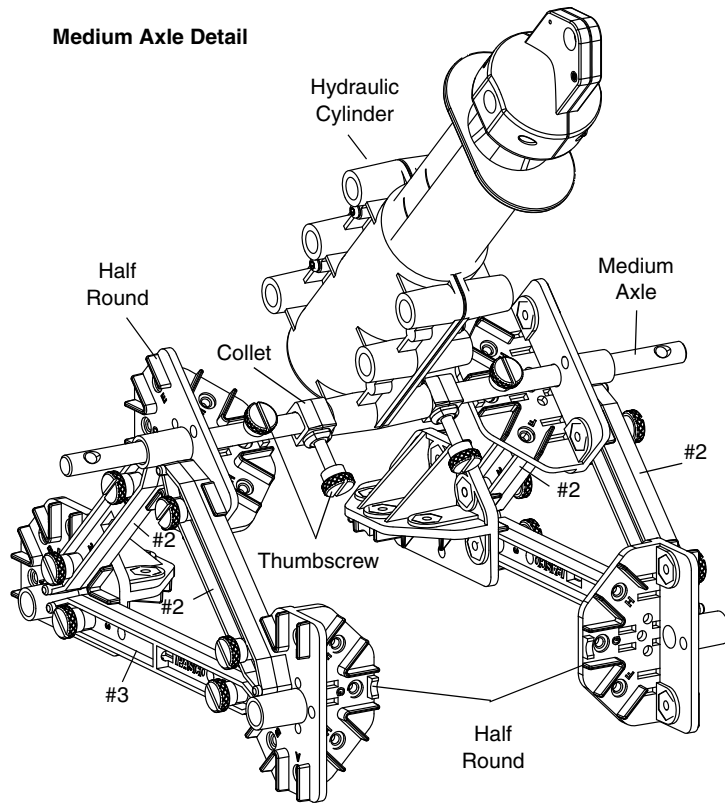
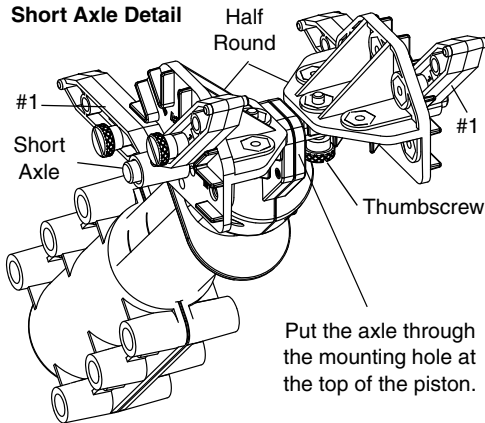

# Fork Lift

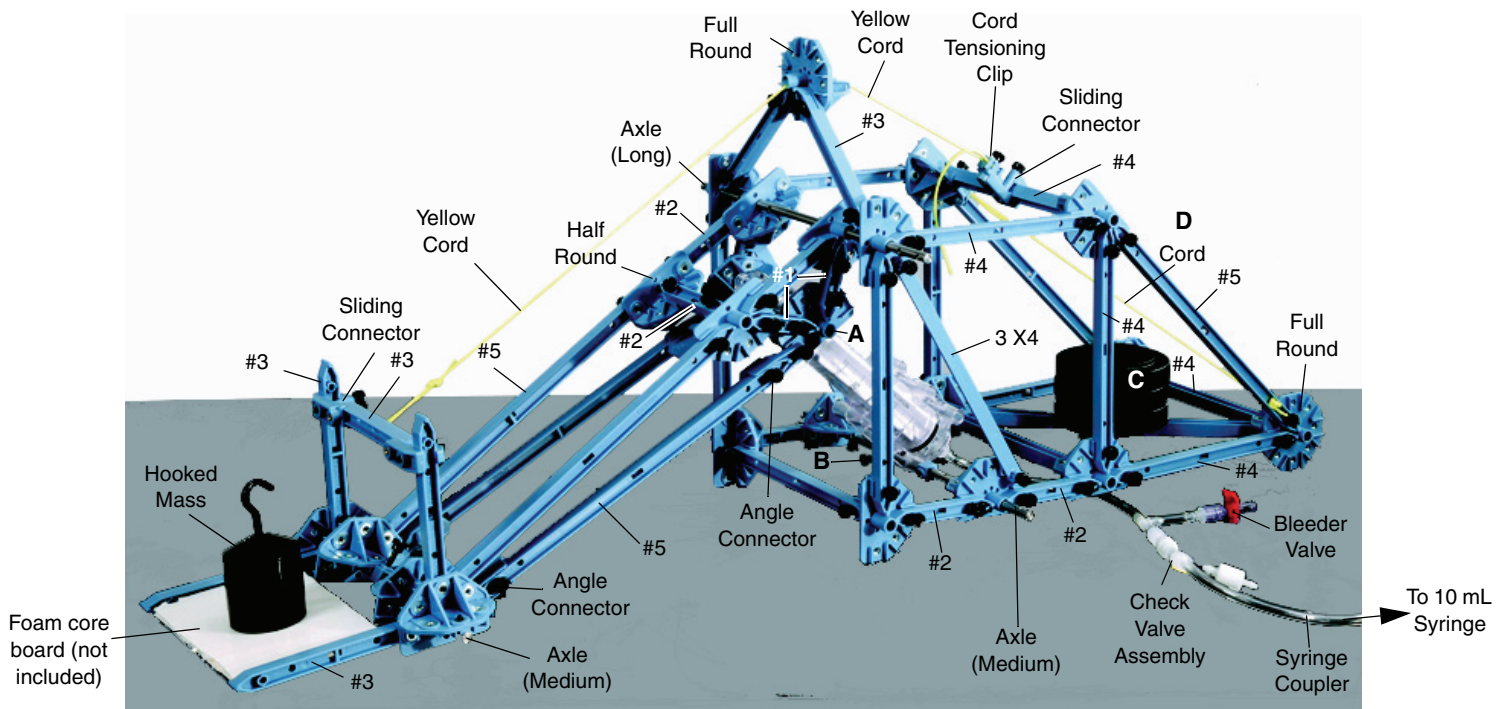

**A.** Put a short axle through the longer hole in the piston cap.

**C.** Place large slotted masses at the end of the base as a counterweight.

**B.** Put collets on both sides of the cross-brace the back of the base.

**D.** Tie cords diagonally to the trunnion at the bottom of the base.

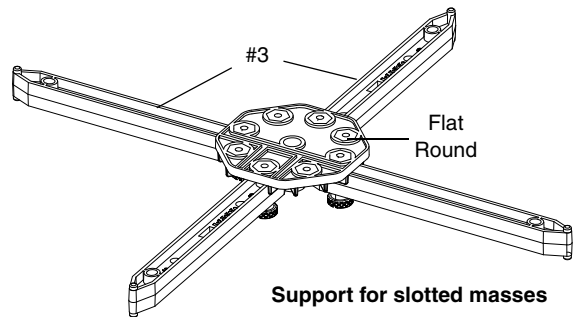

**Support for slotted masses**

Tie one end of the cord to the middle of the #3 beam.

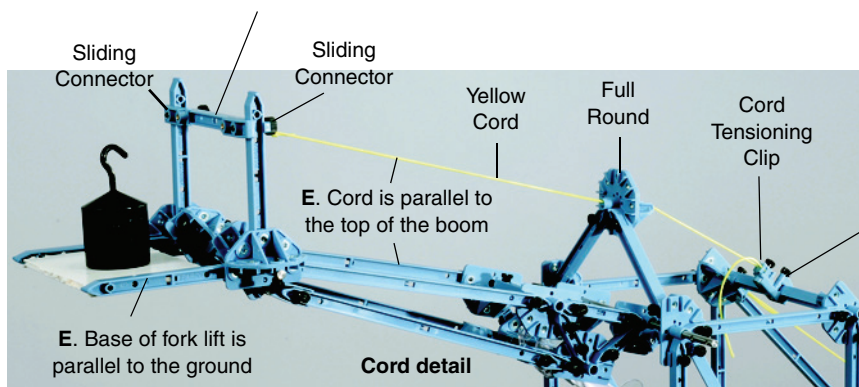

**E.** Tighten the cord so that it is parallel to the top of the boom when the base of the fork lift is parallel to the ground.

| Extra Equipment        | Model              |
|------------------------|--------------------|
| Hooked Mass Set        | SE-8759            |
| Large Slotted Mass Set | ME-7566 or ME-7489 |
| Yellow Cord (2 pack)   | ME-9876            |
| Foam core board        | not included       |

# Fork Lift Details

## Axes and Hydraulic Cylinder Details

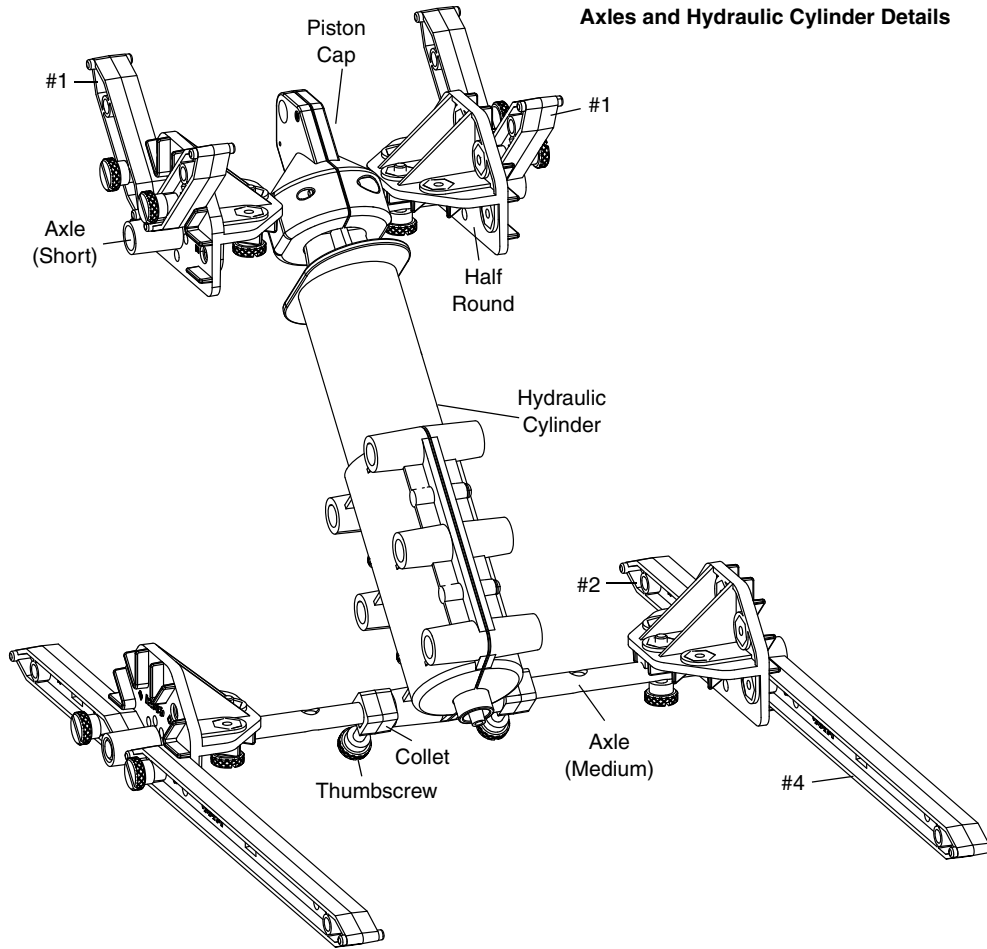

## Boom Axle Details

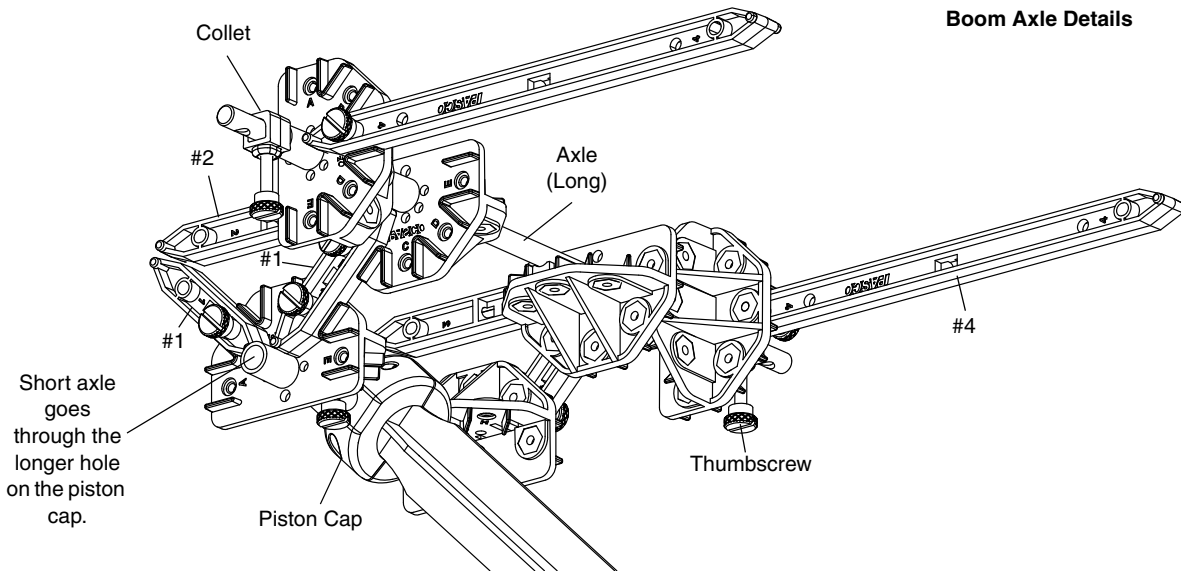

# Scissors Lift

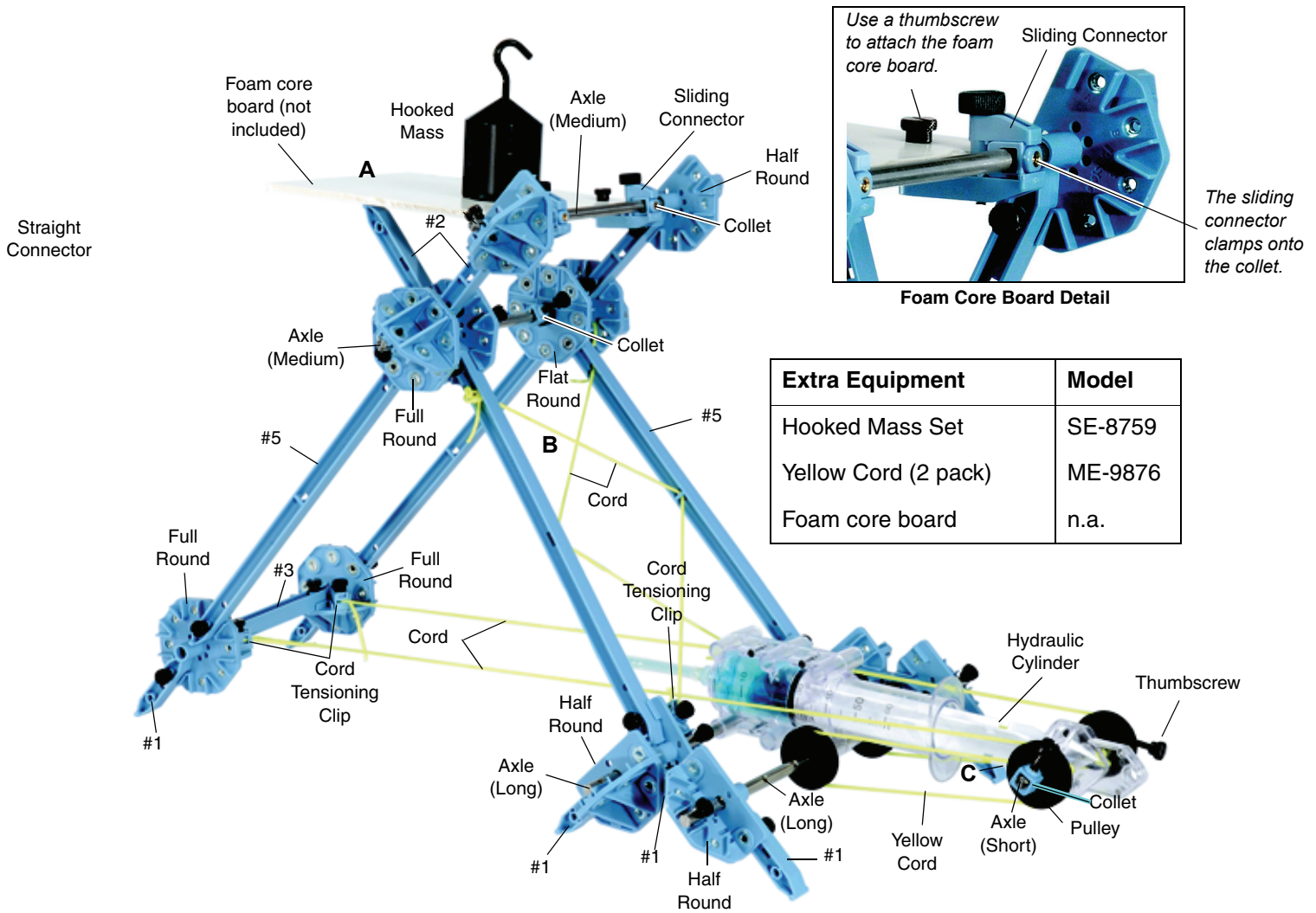

| Extra Equipment      | Model   |
|----------------------|---------|
| Hooked Mass Set      | SE-8759 |
| Yellow Cord (2 pack) | ME-9876 |
| Foam core board      | n.a.    |

**A.** The piece of foam core board shown is approximately 12.5 cm by 17 cm.

**B.** Use cord to cross-brace the legs of the scissors lift.

**C.** Tie one end of the cord to the short axle.

### Lower Axle Details

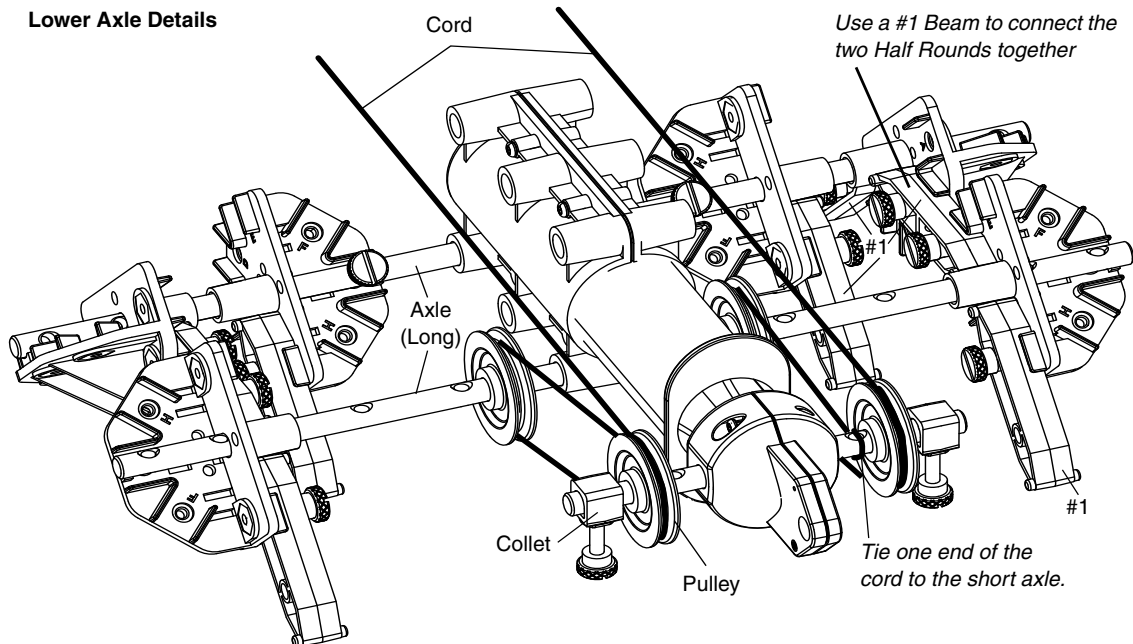

# Ideal Gas Law

## Introduction

The Ideal Gas Law Apparatus, TD-8596A, allows simultaneous measurements of temperature and pressure of a gas as it is compressed. A low thermal mass thermistor is built into the base of the syringe to measure temperature changes inside the syringe. The response time is around 0.5 second. The plunger is equipped with a mechanical stop that protects the thermistor, and also allows for a predetermined change in volume. The apparatus has a mini stereo plug temperature connector that connects directly to a port on a temperature sensor and a quick-release pressure connector. As the plunger of the syringe is depressed, the volume decreases while pressure and temperature increase. **NOTE:** This experiment requires the “A” version of the Ideal Gas Law Apparatus.

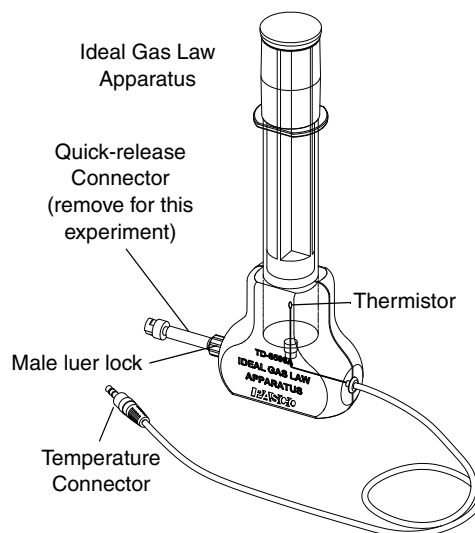

## Equipment Setup

Use the Hydraulic Boom structure with the Ideal Gas Law Apparatus (TD-8596A) and the Pressure/Temperature Sensor (PS-2146).

- Unscrew the male luer lock at the base of the Ideal Gas Law (IGL) Apparatus to remove the short quick-release connector from the apparatus.
- Connect the Pressure Sensor Coupler to the female luer lock on the base of the IGL Apparatus in place of the quick-release connector.
- Connect the side arm of the Pressure Sensor Coupler to the pressure port on the Pressure/Temperature Sensor.
- Connect the Syringe Coupler from the Pressure Sensor Coupler to the Hydraulic Cylinder.
- Plug the mini stereo plug of the Temperature Connector from the IGL Apparatus into the temperature port on the Pressure/Temperature sensor.
- Plug the Pressure/Temperature Sensor and the Rotary Motion Sensor into a PASCO Interface. (NOTE: You may want to use a PASport Extension Cable to connect the Pressure/Temperature Sensor to the interface.)



**PS-2500 PASport  
Extension Cable**



**Procedure**

Set the plunger for a volume of 40 cubic centimeters (cc). Hold the base of the IGL Apparatus firmly against a sturdy horizontal surface.

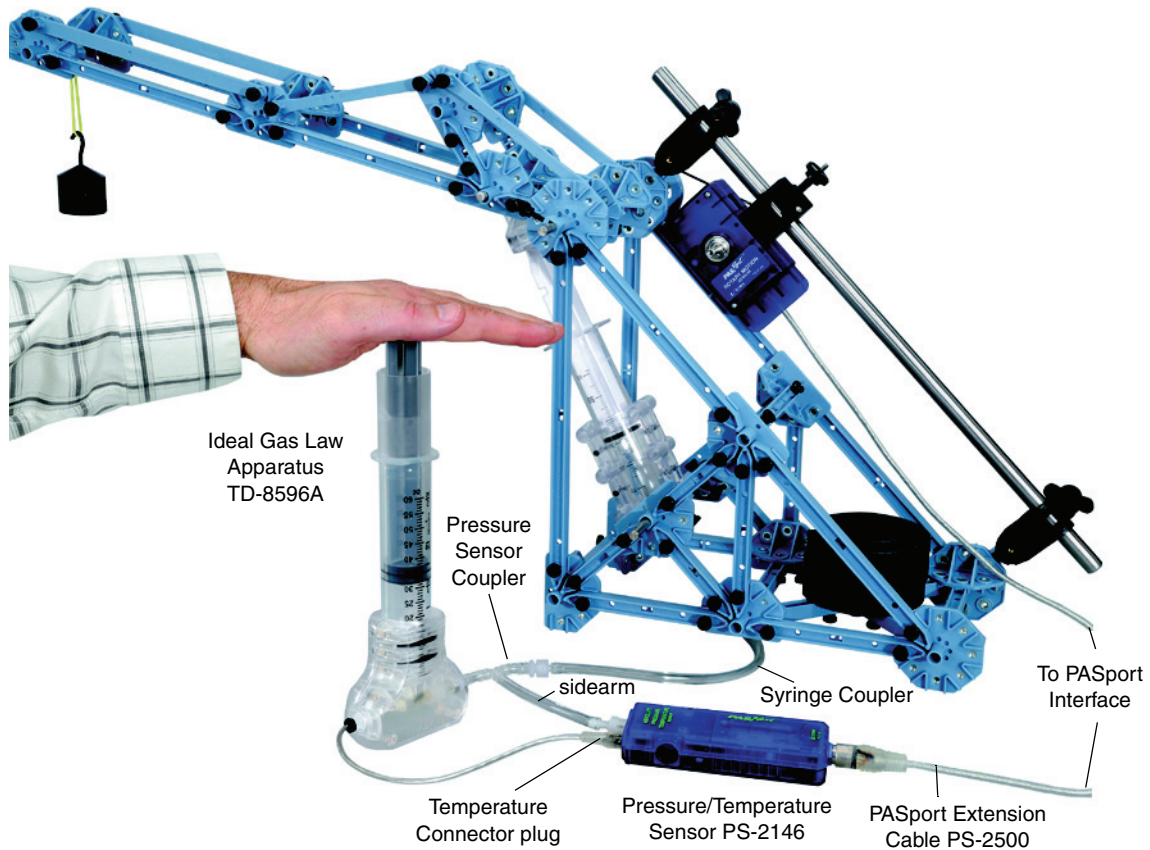

Slap down on the plunger with the palm of your hand to fully compress the gas inside the syringe. Hold this position until the temperature and pressure have equalized and are no longer changing.

| Extra Equipment             | Model       |
|-----------------------------|-------------|
| Hooked Mass Set             | SE-8759     |
| Pressure/Temperature Sensor | PS-2146     |
| Ideal Gas Law Apparatus     | TD-8596A    |
| PASCO Interface             | see catalog |
| PASport Extension Cable*    | PS-2500     |

\*Optional

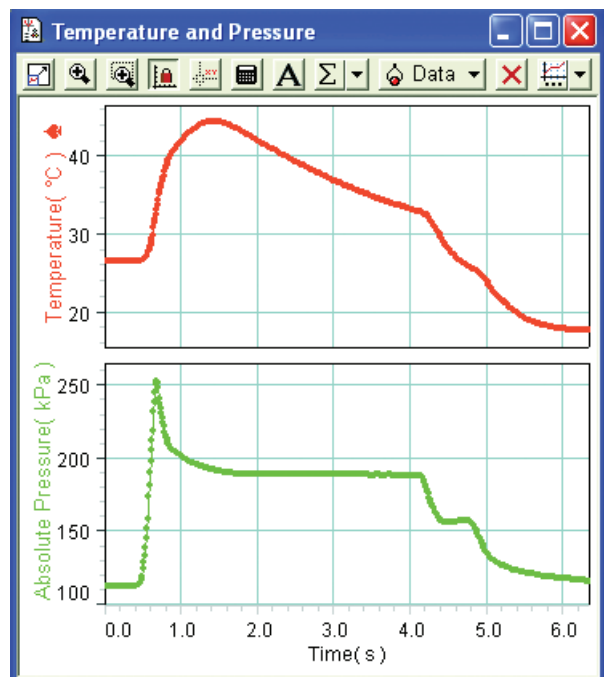

# Spares Part Numbers

**ME-6985 Flexible I-Beam Set**

- #5 Flexible Beam (24 cm) - 16
- #4 Flexible Beam (17 cm) - 16
- #3 Flexible Beam (11.5 cm) - 16

**ME-6986 Structures Rod Clamp (2 pack)**

**ME-6987 Flat Structures Members**

- Flat 3 x 4 Beam (19 cm) - 16
- Flat #4 Beam (17 cm) - 16
- Flat 2 x 3 Beam (12.5 cm) - 16

**ME-6993 Truss Set Members**

- #5 Beam (24 cm long) - 24
- #4 Beam (17 cm long) - 54
- #3 Beam (11.5 cm long) - 54
- #2 Beam (8 cm long) - 24
- #1 Beam (5.5 cm long) - 24
- Half Round Connector - 42

**ME-6994 Truss Set Screws**

- Screw (6 - 32) - 300

**ME-6996 Cord Lock Spares**

- Cord Tensioning Clip - 32
- Cord, Braided, #18 Yellow - 1 roll

**ME-6997 Full Round (XYZ) Connectors**

- Full Round Connector - 6
- Flat Connector - 6
- PAStack Connector\* - 6

*\*1/4 - 20 Thumbscrew and Square Nut*

**ME-6998A Axle Spares**

- 1/2 by 1/4 by 1/4 Spacer - 12
- “O” Ring - 12
- Axle, Short (10.4 cm) - 2
- Axle, Medium (21.3 cm) - 2
- Axle, Long (26.6 cm) - 2
- Collet - 24
- Pulley - 12
- Wheel - 4
- Tire - 4

**ME-6999A Angle Connector Spares**

- Angle Connector - 24
- Straight Connector - 24
- Sliding Connector - 12

**ME-9876 Yellow Cord (2 pack)**

- Cord, Braided, #18 Yellow - 2 rolls

## Summary of Extra Equipment Needed

| Extra Equipment (Model)                      | Where Used                               |
|--|--|
| Hooked Mass Set (SE-8759)                    | All                                      |
| Yellow Cord (ME-9876)                        | All                                      |
| Large Slotted Mass Set (ME-7566 or ME-7589)  | Hydraulic Boom, Fork Lift, Ideal Gas Law |
| Structures Rod Clamp (ME-6986)               | Hydraulic Boom, Ideal Gas Law            |
| 45-cm Steel Rod (ME-8736)                    | Hydraulic Boom, Ideal Gas Law            |
| Rotary Motion Sensor (PS-2120)               | Hydraulic Boom, Ideal Gas Law            |
| Ideal Gas Law Apparatus (TD-8596A)           | Ideal Gas Law                            |
| Pressure/Temperature Sensor (PS-2146)        | Ideal Gas Law                            |
| Absolute Pressure Sensor (PS-2108)           | Hydraulic Boom                           |
| PASport Interface (see catalog or web site)  | Hydraulic Boom, Ideal Gas Law            |
| Foam core board (art or office supply store) | Fork Lift, Scissors Lift                 |

## Technical Support

For assistance with any PASCO product, contact PASCO at:

Address: PASCO scientific  
10101 Foothills Blvd.  
Roseville, CA 95747-7100

Phone: 916-786-3800 (worldwide)  
800-772-8700 (U.S.)

Fax: (916) 786-7565

Web: [www.pasco.com](http://www.pasco.com)

Email: [support@pasco.com](mailto:support@pasco.com)

For more information about the Hydraulics Structures Set and the latest revision of this Instruction Manual, visit:

[www.pasco.com/go?ME-6984](http://www.pasco.com/go?ME-6984)

**Limited Warranty** For a description of the product warranty, see the PASCO catalog.

**Copyright** The PASCO scientific 012-11726A *Hydraulics Structures Set Instruction Manual* is copyrighted with all rights reserved. Permission is granted to non-profit educational institutions for reproduction of any part of this manual, providing the reproductions are used only in their laboratories and classrooms, and are not sold for profit. Reproduction under any other circumstances, without the written consent of PASCO scientific, is prohibited.

**Trademarks** PASCO and PASCO scientific are trademarks or registered trademarks of PASCO scientific, in the United States and/or in other countries. All other brands, products, or service names are or may be trademarks or service marks of, and are used to identify, products or services of, their respective owners. For more information visit [www.pasco.com/legal](http://www.pasco.com/legal).

**Patents Pending:** The following PASCO products have patents pending:

|                                  |   |
|----------------------------------|---|
| ME-6990 Truss Set                | ME-6991 Bridge Set                        |
| ME-6992A Advanced Structures Set | ME-6993 Truss Set Members                 |
| ME-6994 Truss Set Screws         | ME-6995 Road Bed Spares                   |
| ME-6996 Cord Lock Spares         | ME-6997 Full Round (XYZ) Connector Spares |
| ME-6998 Axle Spares              | ME-6999A Angle Connector Spares           |
| PS-2198 Load Cell Amplifier      | PS-2199 Load Cell and Amplifier Set       |
| PS-2200 100 N Load Cell          | PS-2201 5 N Load Cell                     |
| PS-2205 Dual Load Cell Amplifier |   |

