



Horizon Energy Box

User Manual

CE Model No.: FCJJ-40

 **Warning**

Safety Information

Before you start working with the Horizon Energy Box take notice of the following.

Under certain circumstances, hydrogen can create an explosive gas mixture.

Though these devices in this box are designed such that they can be used as described without danger, the advice below must be followed at all times:

- The fuel cell and hydrogen storage may not be operated without supervision.
- Hydrogen (H₂) is much lighter than air and thus rises rapidly. In conjunction with oxygen, a gas mixture capable of explosion can form. A potentially explosive mixture arises for hydrogen concentrations from 4.0 to 77.0% in air. Therefore, it holds that:
- The fuel cell must only be operated either outside or in sufficiently ventilated rooms.
- Oxygen (O₂) is a strongly oxidizing gas. When this gas gets in contact with organic substances (e.g. oil, grease) spontaneous combustion may occur at room temperature.
- Do not insert the cables into an electrical outlet.
- Do not connect the fuel cell or motor to other power sources.
- The removing and inserting of batteries is to be conducted by the adults only. Ensure to respect the polarity.
- Non-rechargeable batteries are not to be recharged.
- Different types of batteries such as rechargeable, alkaline and standard batteries or new and used batteries are not to be mixed and should be used separately.
- The battery pack cables are not to be inserted into an AC socket.
- The supply terminals of the battery pack are not to be short-circuited.
- The two spare red & black cables are not to be inserted into an AC socket.
- Exhausted batteries are to be removed from the battery pack.
- Dispose of dead batteries properly and without delay.
- Do not attach the battery wires directly to each other.

Safe Experimentation

Here are some important instructions for parents, teachers, and students. All activities described in this manual can be conducted without risk if you follow instructions and rules conscientiously.

To avoid the risk of property damage, serious injury or death:

1. Read carefully and fully understand the instructions before assembling this kit.
2. This product is intended only for use by persons 14 years old and up, and only under the supervision of adults who have read and understood the instructions in this user manual.
3. Pay special attention to the indications of quantity and to the sequence of the individual steps.
4. Some parts are small and fragile: please be careful when handling and connecting parts to avoid breakage. Handle all parts and components with care.
5. Do not attempt to use any part, item, or component provided in this kit for any other purpose than what is instructed in this manual. Do not attempt to disassemble any part, item or component in this kit.
6. Keep small children away, because this kit contains small parts that could be swallowed.
7. Wires are not to be inserted into socket-outlets.
8. Save these instructions and review frequently during use.
9. Do not use any other parts or devices than those delivered with the kit.
10. Do not eat, drink, or smoke near the fuel cell device and hydrogen storage.
11. Use fuel cell and hydrogen storage only at a site with good ventilation and keep all sources of ignition away.
12. Clean your hands after use.

Horizon Energy Box User Manual

Table of Contents

Safe Information	Inside front cover
Parts List	1
Hydrogen Energy	3
Wind Energy	9
Solar Energy	20
Bio-Energy	24
Mechanical Energy	30
Thermanl Energy	36
Salt Water Energy	42
Multi Energy Powered Car.	47
REM User Guide	63

Parts List:

- | | | |
|-----------------------------|--------------------------------|--------------------------------|
| 1. Hand crank generator | 19. Assembly lock | 37. Solar panel support |
| 2. Ethanol fuel cell module | 20. Main body assembly | 38. Heavy fan module |
| 3. Reversible fuel cell | 21. Variable resistor module | 39. Fan module |
| 4. Salt water fuel cell | 22. Base assembly | 40. Fan blade |
| 5. Multi car chassis | 23. Blade A (3pcs) | 41. Ethanol fuel tank with lid |
| 6. Battery pack | 24. Blade B (3pcs) | 42. Wires |
| 7. LED module | 25. Blade C (3pcs) | 43. Wheel |
| 8. Mini fuel cell base | 26. Windpitch post assembly | 44. Purging valve |
| 9. Potentiometer | 27. Spanner | 45. Clamp |
| 10. Super capacitor | 28. Screwdriver | 46. PH paper |
| 11. Water tank base | 29. Water & oxygen tank | 47. Silicon tubes |
| 12. Solar panel | 30. Water & hydrogen tank | 48. Red & black pins |
| 13. HYDROSTIK PRO | 31. Fuel solution container | 49. Fan blade & wheel adapter |
| 14. Pressure regulator | 32. U locker for HYDROSTIK PRO | 50. Windpitch post screws |
| 15. Mini fuel cell | 33. HYDROSTIK PRO suport | 51. Reversible fuel cell |
| 16. Thermoelectrical system | 34. Syringe | 52. Thermometers |
| 17. Rotor Base | 35. Fuel cell base | 53. REM USB cable |
| 18. Blade holder | 36. Multi connection base | 54. REM |

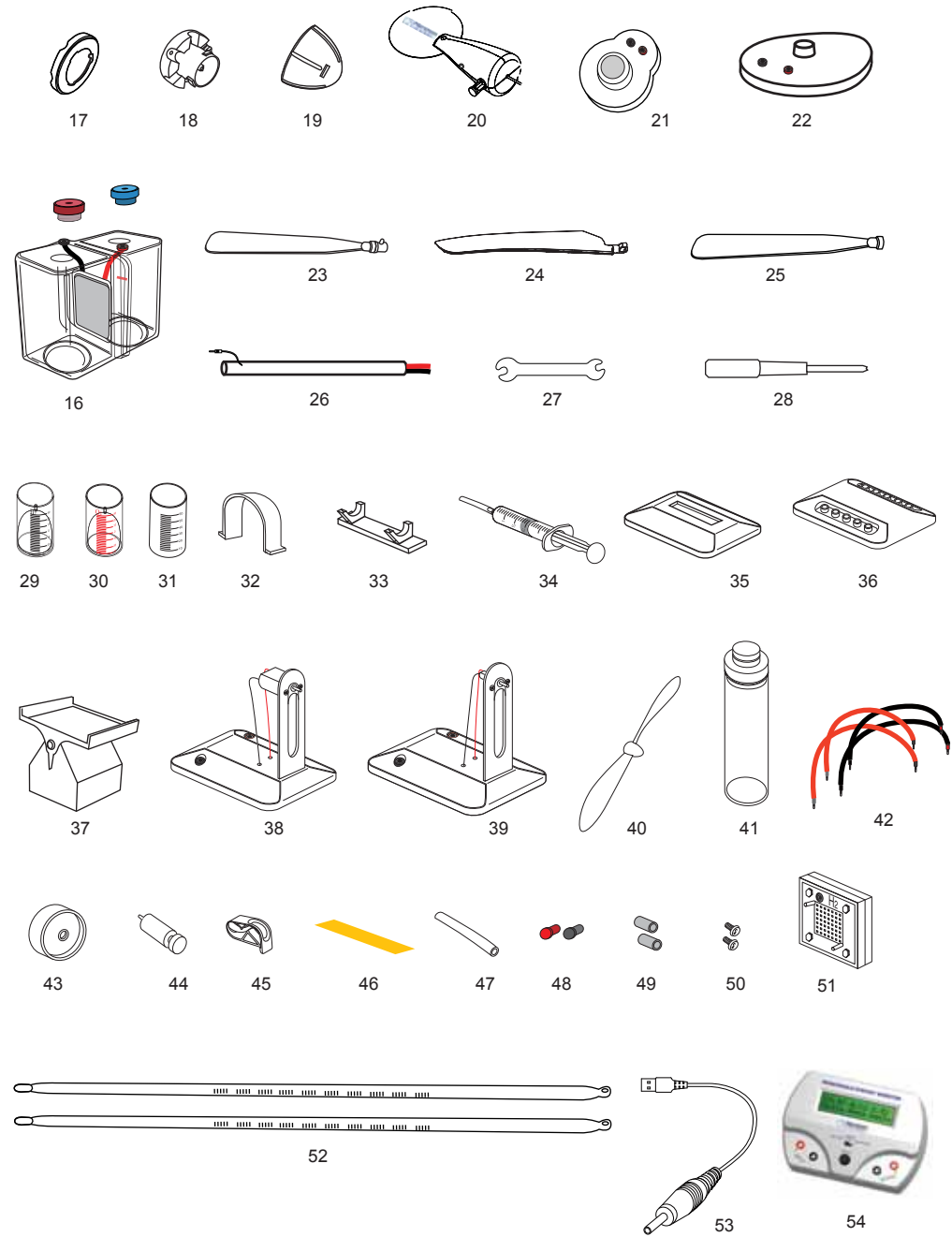
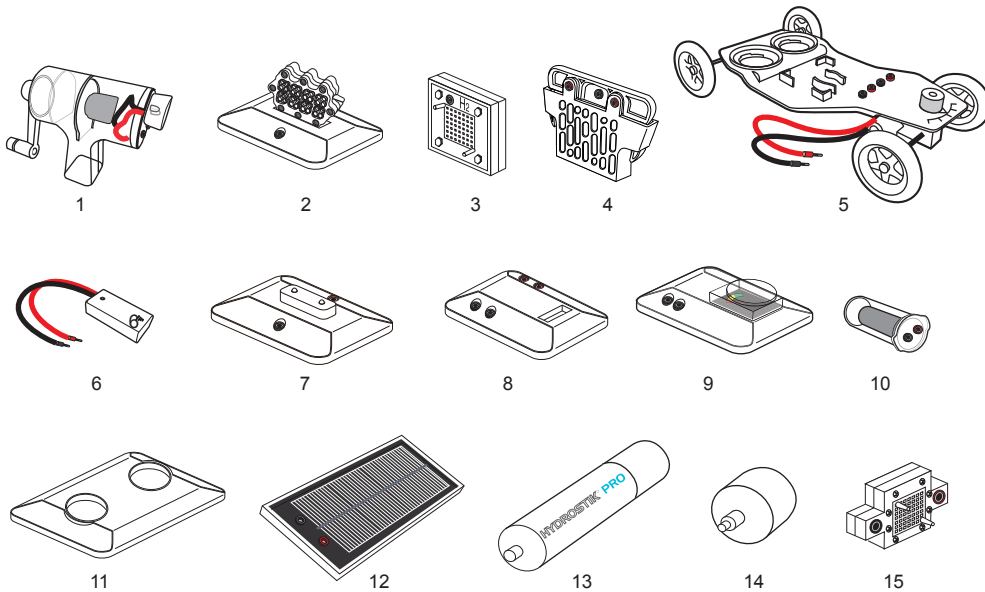

Hydrogen Energy

What you need:

- a. Micro-fuel cell
- b. HYDROSTIK PRO (hydrogen storage)*
- c. Pressure regulator
- d. Heavy fan module
- e. Fan blade
- f. HYDROSTIK PRO base
- g. Micro-fuel cell base
- h. Wires
- i. Fan blade adapter
- j. HYDROSTIK PRO support
- k. Clamp
- l. Silicon tubes

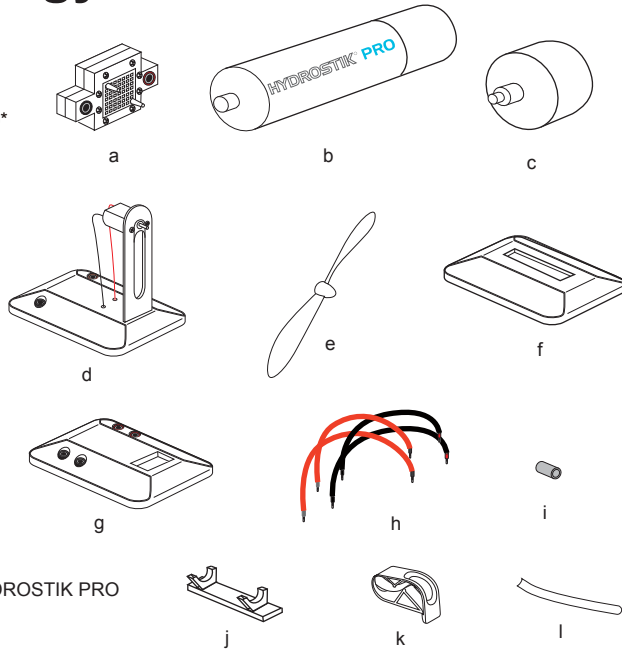

You will also need the following items (not included in this box):

- HYDROFILL PRO for charging the HYDROSTIK PRO
- Scissors

*Note: The HYDROSTIK PRO contains no hydrogen when you get it for the first time, you have to fully charge the HYDROSTIK PRO with the refilling station HYDROFILL PRO (not provided) or hydrogen charging tube (not provided). Or please contact your local dealer for detailed information.

HYDROSTIK PRO SAFETY INFORMATION

- DO NOT try to disassemble, open or repair the cartridges when broken or worn out!
- DO NOT store cartridges under direct sunlight.
- Keep it away from fire. Fire Hazard!
- Keep in a safe, dry and cool place.
- Keep away from temperatures above 50°C while filling, storage and using.
- Provide adequate ventilation and refrain from placing items on or around the appliance during operation. Refrain from placing the appliance in enclosures or causing the appliance to not vent freely.
- Keep away from alkaline and acidic environment.
- This is not toy – keep away from children.
- The HYDROSTIK PRO must be placed horizontally when it is being charged otherwise the cartridge can crack!
- HYDROSTIK PRO contents are flammable. Do not disassemble. Avoid contact with HYDROSTIK PRO contents.
- Remove the HYDROSTIK PRO from the pressure regulator immediately after use.
- Hydrogen shall be stored, handled and used with caution so life and health are not jeopardized and the risk of property damage is minimized.
- This appliance is not tested for use with medical devices.
- Save these instructions and review frequently during use.

Step 1. Preparing the micro-fuel cell module

- a. Insert the PEM fuel cell (a) into its slot on the base (g). Make sure the fuel cell fits well in its base.

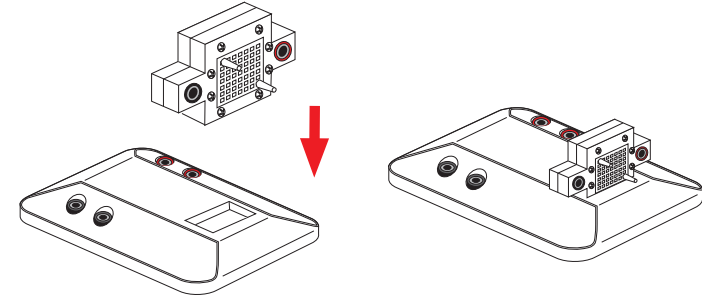

- b. Use the short black & red wires to connect the fuel cell to its base as shown below. Make sure you respect the color code when you plug each wire into the corresponding socket.

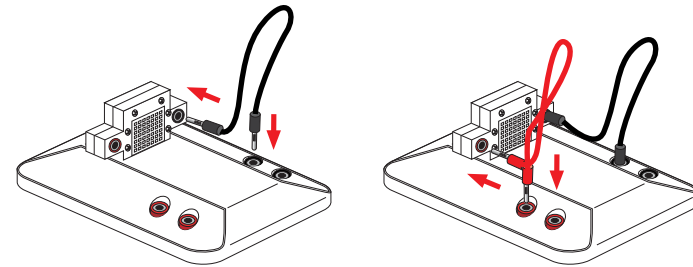

Step 2. Preparing the fan module

- a. Connect the adapter (i) to the motor axis. Insert the fan blade (e) onto the adapter. Make sure the connection is tight.

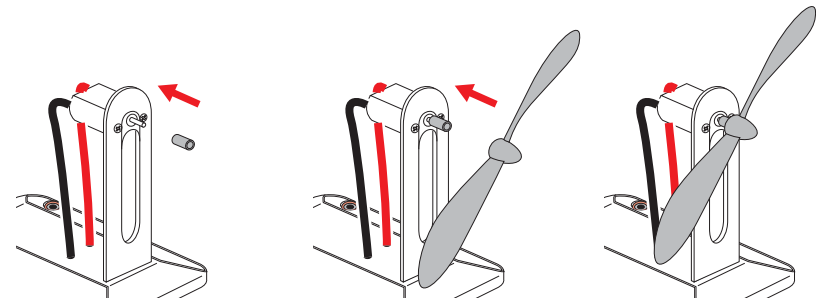

Step 3. Connect the fan to the fuel cell

a. Cut a 6cm long silicon tube. Let the tube go through the clamp. Connect one end of the tube to the inlet of the fuel cell (lower nozzle). Keep the clamp closed.

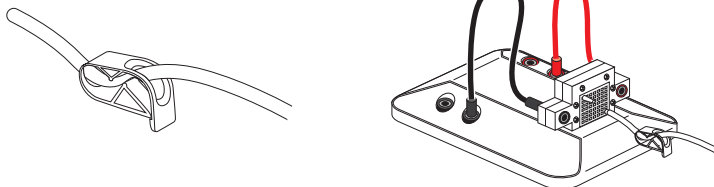

b. Use the black & red wires to connect the fan module to the fuel cell module. Make sure you respect the color code when you plug each wire into the corresponding socket.

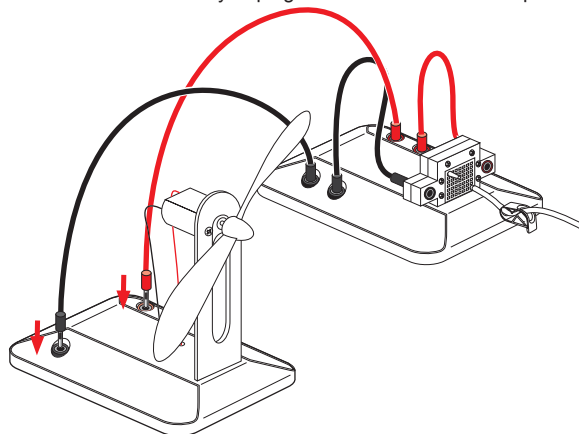

Step 4. Preparing the hydrogen source

a. Cut a 15cm long silicon tube. Unscrew the pressure regulator and put the bolt around the tube. Connect the tube to the pressure regulator.

b. Connect the other end of the tube from the pressure regulator to the remaining nozzle of the fuel cell. Make sure the connection is tight.

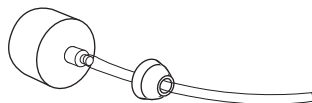

c. Place the HYDROSTIK PRO support (j) onto its base (f).

d. Place the HYDROSTIK PRO onto its support.

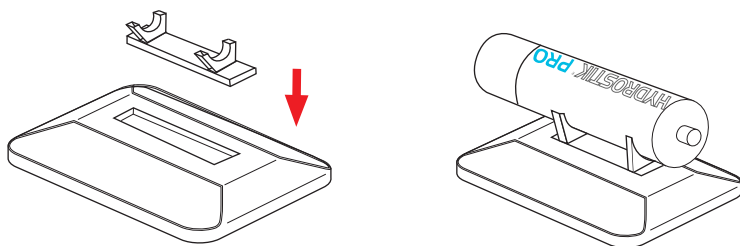

Step 5. Power the fan with the hydrogen energy

a. Screw the HYDROSTIK PRO to the pressure regulator tightly.

b. Open the clamp to purge some amount of hydrogen out and then quickly close. The fan will immediately start to run.

Note:

1. If the fan does not run at this time, it may need to be flicked with your finger to start.

2. After every 10 minutes, it is suggested open the clamp to release some amount of hydrogen out to ensure the good performance of the fuel cell.

3. Remove the HYDROSTIK PRO from the pressure regulator immediately after use.

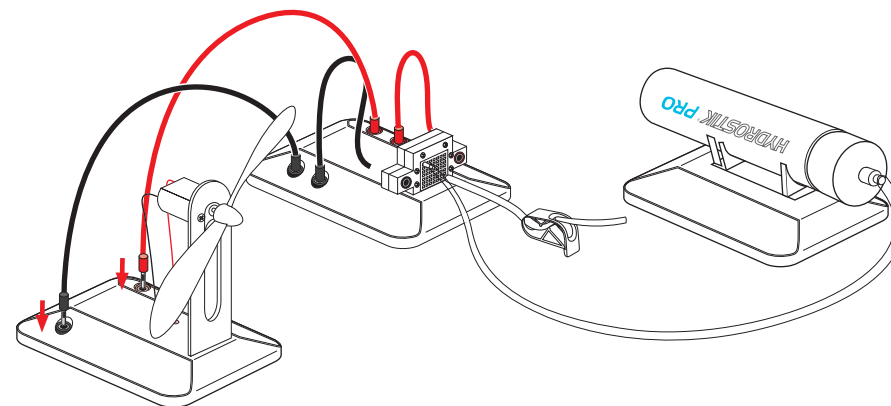

Now you may use a multi-meter (not provided) or Horizon's REM to measure the output voltage & current produced by the fuel cell or do various experiments.

Why Fuel Cells and Hydrogen?

Fuel cells can be thought of as alternative energy devices. They convert chemical energy into electrical energy. Hydrogen fuel cells do this very cleanly, with no toxic emissions, and with a high efficiency.

Fuel cells do not generate energy out of thin air. They use hydrogen. Hydrogen is an outstanding carrier of energy. Hydrogen is non-toxic, renewable, easily obtained, and packed with energy. When it combusts with oxygen, it turns into water. This water can again be split into hydrogen and oxygen via electrolysis. The generated hydrogen can be combusted once again, thus undergoing a limitless cycle without toxic emissions. With a fuel cell, you can convert hydrogen into electric current without combustion.

Fossil fuels are converted into usable energy through combustion. The energy released during combustion is inherently difficult to capture and inefficient. It also produces carbon dioxide, which cannot easily be converted back into a usable fuel. A fossil fuel combustion engine at a power plant is only about 30 to 40% efficient. This means it converts only 30 to 40% of the energy in the fossil fuels to usable energy (electricity). Engines in a car are even less efficient, and reach the level of 15 to 20% of efficiency. Where does the rest of the energy go? It escapes as heat, vibration, and noise.

On the other hand, fuel cells can operate at 40 to 65% efficiency. This means that they can convert 40 to 65% of the energy contained in hydrogen into electricity.

Step 3. Connect the fan to the fuel cell

a. Cut a 6cm long silicon tube. Let the tube go through the clamp. Connect one end of the tube to the inlet of the fuel cell (lower nozzle). Keep the clamp closed.

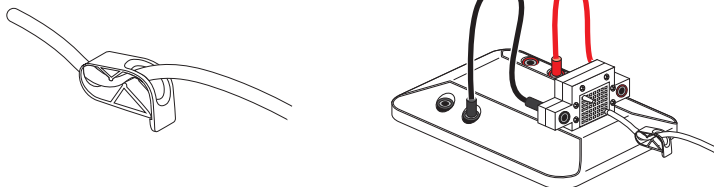

b. Use the black & red wires to connect the fan module to the fuel cell module. Make sure you respect the color code when you plug each wire into the corresponding socket.

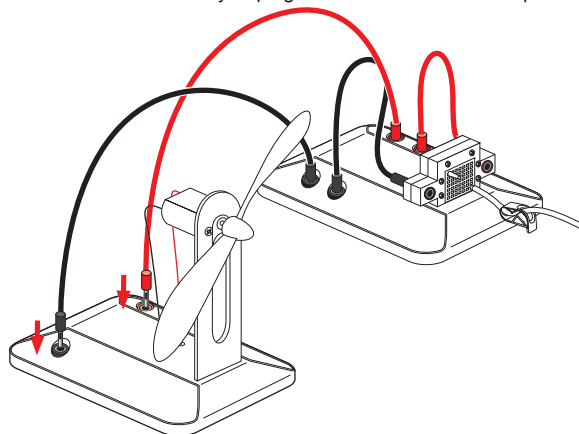

Step 4. Preparing the hydrogen source

a. Cut a 15cm long silicon tube. Unscrew the pressure regulator and put the bolt around the tube. Connect the tube to the pressure regulator.

b. Connect the other end of the tube from the pressure regulator to the remaining nozzle of the fuel cell. Make sure the connection is tight.

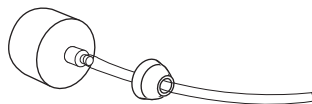

c. Place the HYDROSTIK PRO support (j) onto its base (f).

d. Place the HYDROSTIK PRO onto its support.

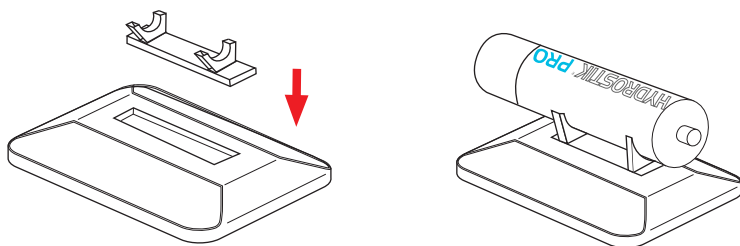

Step 5. Power the fan with the hydrogen energy

a. Screw the HYDROSTIK PRO to the pressure regulator tightly.

b. Open the clamp to purge some amount of hydrogen out and then quickly close. The fan will immediately start to run.

Note:

1. If the fan does not run at this time, it may need to be flicked with your finger to start.

2. After every 10 minutes, it is suggested open the clamp to release some amount of hydrogen out to ensure the good performance of the fuel cell.

3. Remove the HYDROSTIK PRO from the pressure regulator immediately after use.

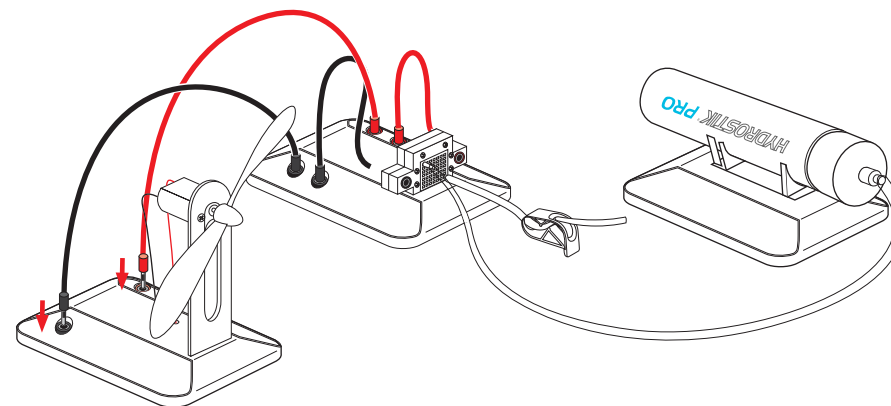

Now you may use a multi-meter (not provided) or Horizon's REM to measure the output voltage & current produced by the fuel cell or do various experiments.

Why Fuel Cells and Hydrogen?

Fuel cells can be thought of as alternative energy devices that unlock the power of hydrogen. They convert chemical energy into electrical energy. Hydrogen fuel cells do this very cleanly, with no toxic emissions, and with a high efficiency. Hydrogen and fuel cell technologies have many potential clean energy applications – from running our vehicles, to powering our cellular phones and laptops, to heating our hospitals and homes.

Fuel cells do not generate energy out of thin air. They use hydrogen. Hydrogen is an outstanding carrier of energy. Hydrogen is non-toxic, renewable, easily obtained, and packed with energy. When it combusts with oxygen, it turns into water. This water can again be split into hydrogen and oxygen via electrolysis. The generated hydrogen can be combusted once again, thus undergoing a limitless cycle without toxic emissions. With a fuel cell, you can convert hydrogen into electric current without combustion.

Fossil fuels are converted into usable energy through combustion. The energy released during combustion is inherently difficult to capture and inefficient. It also produces carbon dioxide, which cannot easily be converted back into a usable fuel. A fossil fuel combustion engine at a power plant is only about 30 to 40% efficient. This means it converts only 30 to 40% of the energy in the fossil fuels to usable energy (electricity). Engines in a car are even less efficient, and reach the level of 15 to 20% of efficiency. Where does the rest of the energy go? It escapes as heat, vibration, and noise.

On the other hand, fuel cells can operate at 40 to 65% efficiency. This means that they can convert 40 to 65% of the energy contained in hydrogen into electricity.

The development of hydrogen and fuel cell technologies and products around the world will improve the air we breathe, ensure secure and reliable energy, reduce the emissions that cause climate change and create highly skilled jobs.

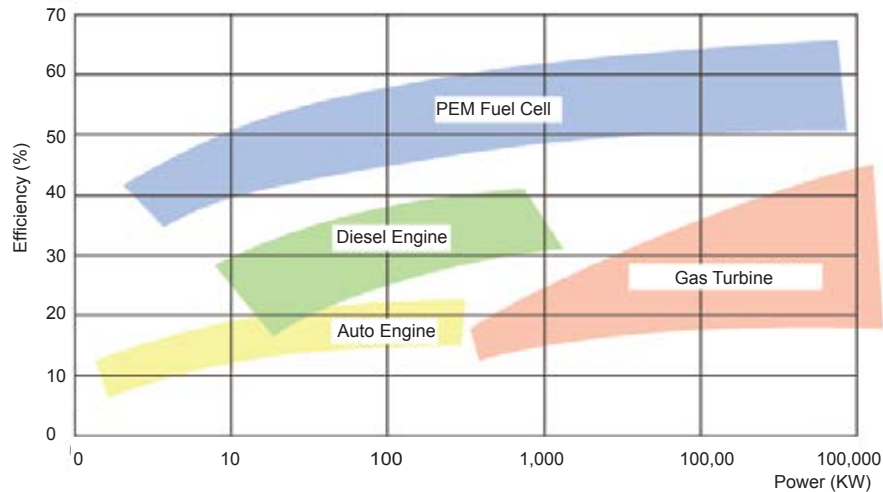

FAQ

- What are the refill options for HYDROSTIK PRO cartridges?
 - HYDROSTIK PRO can be recharged using Horizon's HYDROFILL cartridge refilling solution.
 - You may contact your local Horizon service provider for HYDROSTIK PRO refill support at sales@horizonfuelcell.com
 - If needed HYDROSTIK PRO can be disposed after use, they are fully recyclable and do not contain any harmful materials.
- I want to purchase more HYDROSTIK PRO Metal Hydride Cartridges, should I have received a (gas pressure) regulator of any kind with it?

No, pressure regulators are not included as standard you will need to order those as well. You can purchase one online visiting the Horizon Online Store or contact info@horizonfuelcell.com.
- I would like to exchange my cartridge for a different size, can we do this at any Horizon related outlet?

No, for now we only distribute a single size HYDROSTIK PRO Metal Hydride Cartridge.
- Can I take Metal Hydride cartridge HYDROSTIK PRO abroad?

No more than two spare metal hydride cartridges may be carried by a passenger in carry on baggage, in checked baggage, or on the person.
- Does the HYDROSTIK PRO lose its energy content over time, if I don't use it?

Hydrogen remains stored as a hydride in the HYDROSTIK PRO. The cartridge will not lose its energy or latent hydrogen content if the cartridge is not being used.
- Can we refill HYDROSTIK PRO with our own electrolyzer?

No, the HYDROSTIK PRO can only be recharged using the HYDROFILL or Horizon approved refilling stations.
- How many hours of electricity are provided by a HYDROSTIK PRO Metal Hydride Cartridge?

The HYDROSTIK PRO Metal Hydride Cartridges contain up to 11Wh of electricity. So if drawing 1W from the fuel cell, it will run for 11hours.

8. How can I monitor how much gas is left in a cylinder?

This can be measured by weight, measuring the empty weight gives you the benchmark level and then you can work out the total amount of hydrogen by that 11Liters of Hydrogen =1gram so make sure your scales can work in 1/10th of 1/100th of a gram to get accurate readings. Pressure cannot be used as a measurement of the amount of Hydrogen in the canister as the pressure is almost the same between 10%-90% full.

9. Can I store HYDROSTIK PRO in cars parked in full sun?

HYDROSTIK PRO is advised to be stored in maximum 50C temperatures, but cars parked in full sun can reach inside temperatures which exceed 60C. HYDROSTIK PRO is still safe at these temperatures; however we do not recommend storing HYDROSTIK PRO in such conditions.

10. Where do I recycle a spent or damaged HYDROSTIK PRO?

Contact your local consumer waste recycling center or return the HYDROSTIK PRO to a Horizon Fuel Cell Technologies vendor. Typically, HYDROSTIK PRO can be recycled where rechargeable batteries are recycled.

Recycle Procedures The materials in the HYDROSTIK PRO are 100% recyclable, and so in order to get the HYDROSTIK PRO metal hydride cartridges recycled properly, return the cartridges to your local outlet or distributor.

Normal Disposal Procedures

The HYDROSTIK PRO metal hydride cartridges do not contain any dangerous substances for the environment, we would recommend that they still be disposed of in a similar way you would dispose of a standard battery.

Troubleshooting

- The fan does not run after the HYDROSTIK PRO supplies hydrogen to the fuel cell.
 - The fan may need to be flicked with your finger to start.
 - Recharge the HYDROSTIK PRO fully.
 - Open the clamp to purge a little bit amount of hydrogen out of the system.
 - Make sure the HYDROSTIK PRO is connected to the pressure regulator tightly.
- The fan runs slower than before.
 - Recharge the HYDROSTIK PRO fully.
 - Open the clamp to purge a little bit amount of hydrogen out of the system.

If none of these tips helped solve the problem, go through the instructions from the beginning and make sure you follow each step completely.

If the fan still does not work, contact Horizon technical support at support@horizonfuelcell.com.

Wind Energy

What you need:

1. Blade holder
2. Rotor Base
3. Assembly lock
4. Main body assembly
5. Heavy fan or wheel module
6. Blade A (3pcs)
7. Blade B (3pcs)
8. Blade C (3pcs)
9. Windpitch post assembly
10. Spanner
11. Screwdriver
12. Windpitch base assembly
13. LED module
14. Electrolyzer fuel cell base
15. Mini fuel cell base
16. Electrolyzer fuel cell
17. Water & O2 tank
18. Water & H2 tank
19. Battery pack
20. Silicon tubes
21. Post secure screws
22. Red & black pins
23. Mini fuel cell
24. Clamp
25. Purging valve
26. Fan blade
27. Fan & wheel adapter
28. Water tank base
29. Variable resistor module
30. Wires
31. Wheel
32. Circuit board
33. REM
34. REMUSB cable

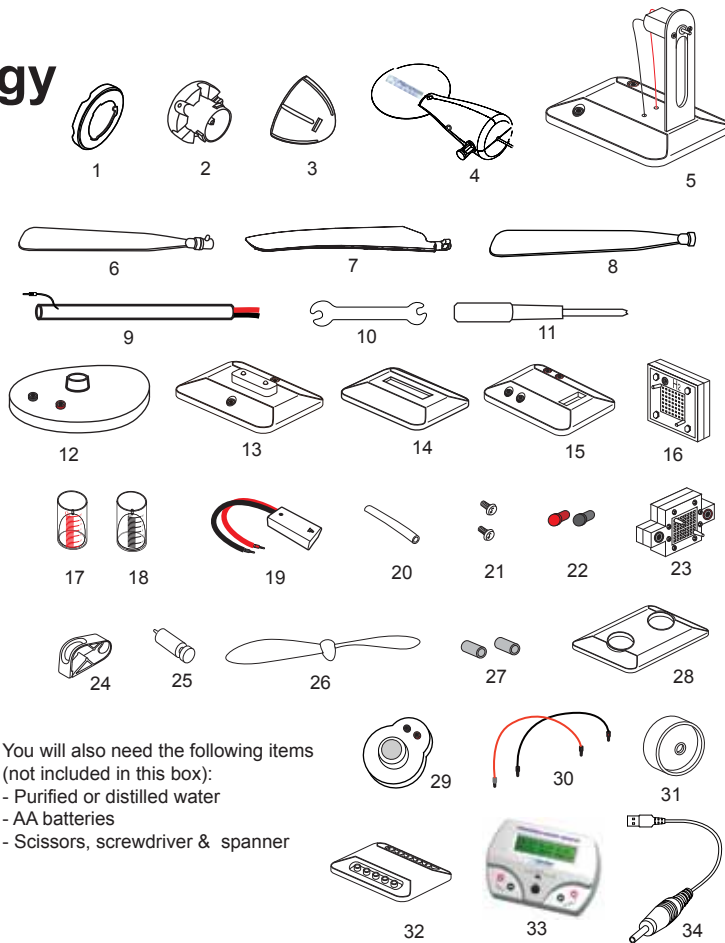

You will also need the following items (not included in this box):
 - Purified or distilled water
 - AA batteries
 - Scissors, screwdriver & spanner

Main Body Assembly Part List

1. Left Housing
2. Right Housing
3. Generator
4. Printed Circuit Board Assembly
5. Polypropylene Vane
6. Screw, M2.5 x 8 mm
7. Hex Nut, M2.5
8. Rotor Base
9. Molded Profile Blade
10. Profile Blade Holder
11. Blade Assembly Lock
12. Polypropylene Sheet Blade
13. Aluminium Post
14. Screw, M3 x 2 mm
15. Output Wire
16. Support Base Assembly
17. Output Socket
18. Post Secure Screw

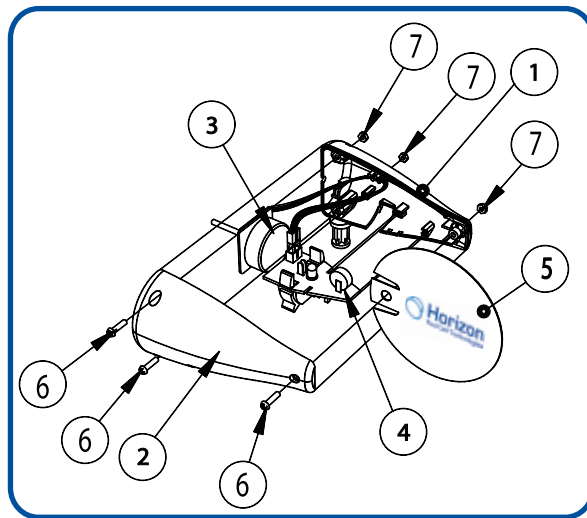

Step 1. Blade Unit Assembly

Profiled Blade:

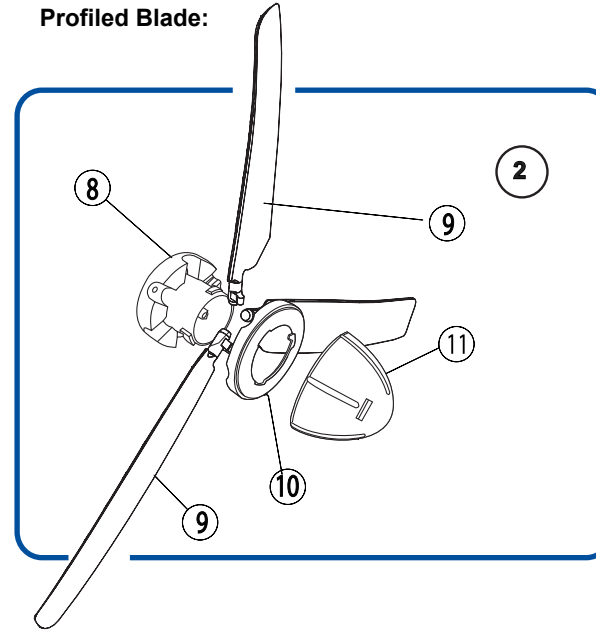

Place the Rotor Base (8) onto the flat surface of a table. Install 3 pcs of the same type of profiled blades (marked B or C) evenly on the Rotor Base. Pay attention that the snap joint must be pushed into the Rotor Base. Place the Blade Holder (10) on top of the installed blades. Pay attention to the direction of the Blade Holder. Screw the Blade Assembly Lock (11) onto the top of the Blade Assembly.

***Do not over tighten the Blade Assembly Lock otherwise you may have a difficult time in unlocking the Blade Unit Assembly.**

Sheet Blade:

Place the Rotor Base (8) onto the flat surface of a table. Install 3 pcs of the same type of Sheet blades (12) (marked A) evenly on the Rotor Base. Pay attention that the snap joint must be pushed into the Rotor Base. Place the Blade Holder (10) on top of the installed blades. Pay attention to the direction of the Blade Holder. Screw the Blade Assembly Lock (11) onto the top of the Blade Assembly.

***Do not over tighten the Blade Assembly Lock otherwise you may have a difficult time in unlocking the Blade Unit Assembly.**

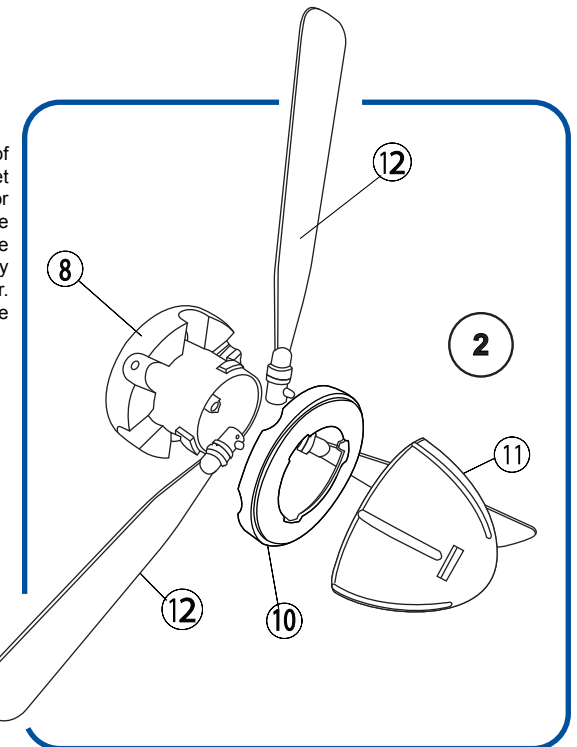

Step 2. Blade Unit Installation

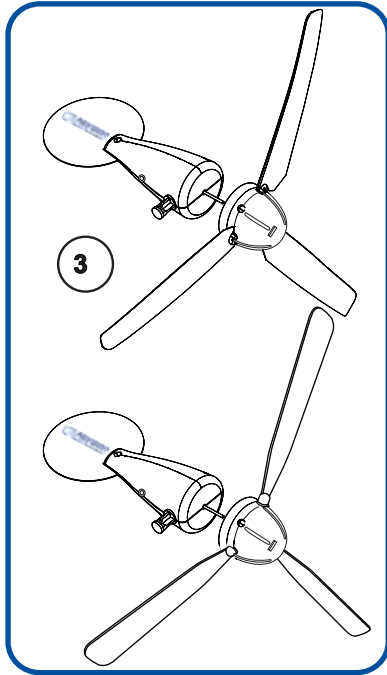

Push the rotor shaft to the rotor base to ensure the main body and rotor head are properly connected. Make sure you press the Blade Unit all the way onto the shaft. Check that the Blade Unit is securely connected onto the shaft of the turbine. If not properly installed, the rotor may not effectively turn the rotor shaft and will not generate electricity.

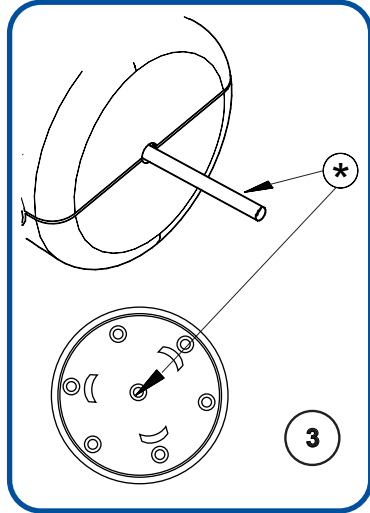

Step 3. Post and Support Base Assembly

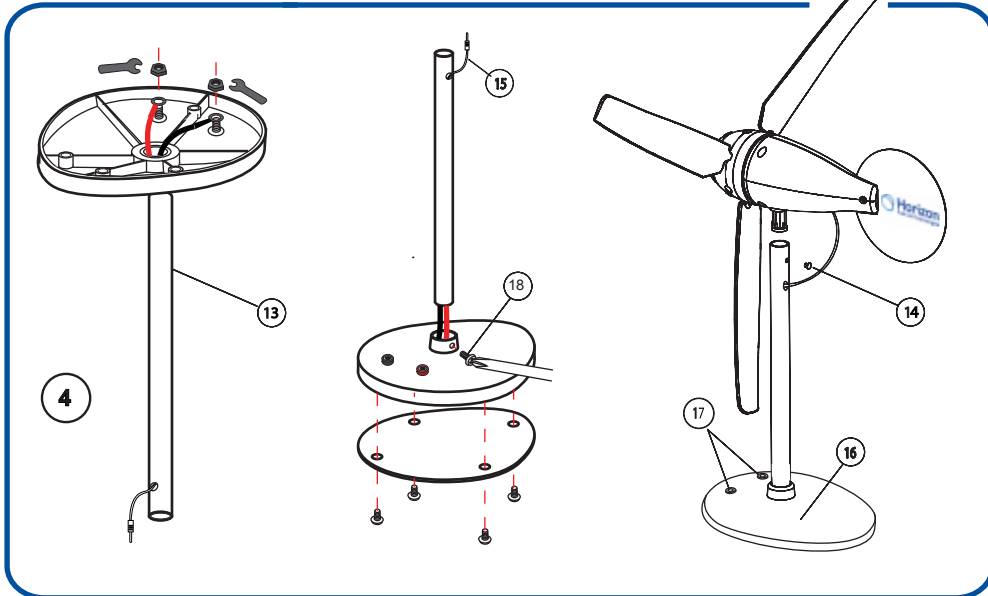

Enable Yawing:

Yaw- To turn about on vertical axis. To move unsteadily or weave.

The wire connector hole should be located on the **same** side of the tube (13) with two vertically aligned holes. Insert the Aluminium Tube into the Support Base. Install the Body Assembly onto the top of the Aluminium Tube and secure it with the screw (14). The screw should be secured from the **back** side of the wind turbine body into the groove of the plastic stud to **enable** yawing and movement of the turbine body.

Disable Yawing (Not shown in the Assembly Drawing):

The wire connector hole should be located on the **opposite** side of the tube (13) with two vertically aligned holes. Insert the Aluminium Tube into the Support Base. Install the Body Assembly onto the top of the Aluminium Tube and secure it with the screw (14). The screw should be secured from the **front** side of the wind turbine body through the hole on aluminum tube into the solid plastic stud to **disable** yawing and movement of the turbine body.

Step 4. Blade Pitch Setting

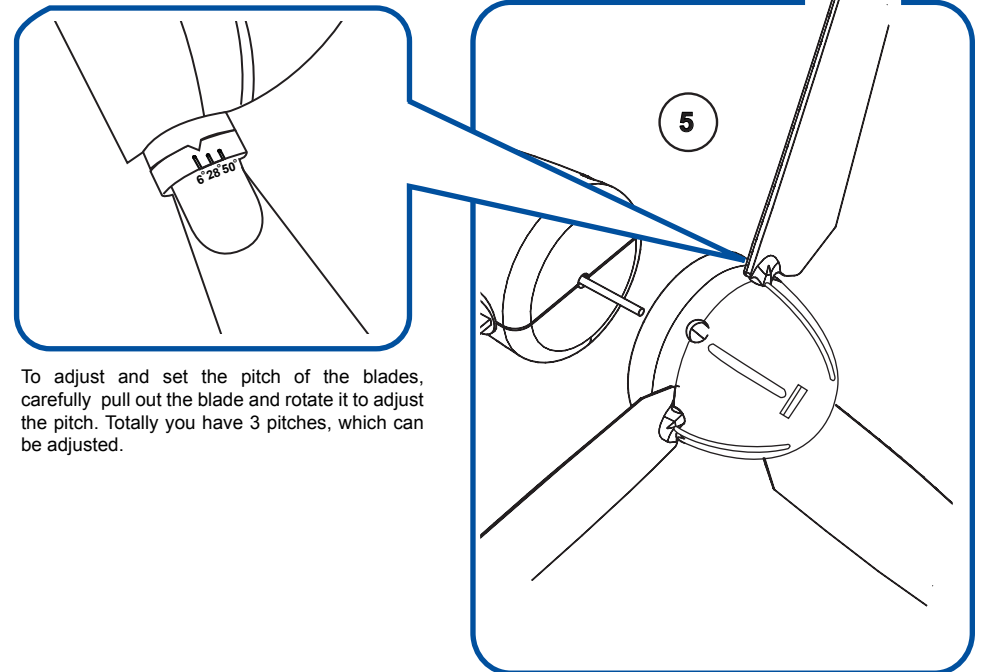

To adjust and set the pitch of the blades, carefully pull out the blade and rotate it to adjust the pitch. Totally you have 3 pitches, which can be adjusted.

The Pitch Angle

The blades themselves have different set angles at different sections to enhance the performance. This setting is to compensate the rotating speed of the blade at different radius (sections) so that the blades will not stall at a particular section. You may have to learn more about a parameter called Tip Speed Ratio to understand more thoroughly. This Ratio defines how fast the turbine is rotating under a wind speed environment. By changing the blade pitch, this ratio will be changed. Thus the output power of the turbine is changed. Each adjustment represents a change of 22 degrees. Therefore, the pitch is allowed to be adjusted from 6 to 50 degrees.

At smaller pitch value settings, the start up wind speed has to be very high. Maximum output power occurs at a pitch of around 28 degrees. The start up wind speed is higher at a lower pitch setting. If the wind speed is low you should increase the pitch so that you can achieve a higher power output.

Wind Kit Technical Specifications:

Below table indicates expected RPM speed, current, voltage, and power when placing the WindPitch in constant windspeed of 10mph when connected to load of 50 Ohms. This level of resistance may be applied using Horizon's variable resistor module included in this box.

Blade Type	No. of Blade	Wind Speed (mph)	Load (Ohm)	Output Voltage (V)	Output Current (mA)	Output Power (W)	Rotor Speed (RPM)
Blade A	3	10	50	1.15	28	0.03	400
Blade B	3	10	50	1.35	30	0.04	490
Blade C	3	10	50	2.50	50	0.125	705

Different Blade Types

There are three types of profiled blades included in the Wind Energy kit. After you obtain the maximum output power with a particular blade type, you may replace with another type of profiled blade and evaluate its performance in comparison.

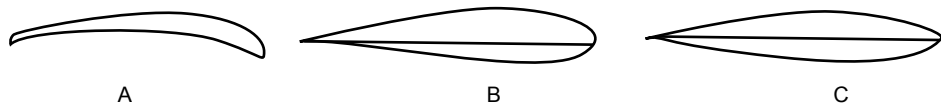

The difference between these 3 profiles is the amount of material on the side facing the wind. All of them have a much more curved profile on the Rear side (down wind side) to increase the distance for the wind to travel. The Blade Type no. is engraved on the root part of the Blade for your reference.

Changing the Number of Blades

There are 6 positions for the installation of blades and it is possible to install up to 6 blades. However, with 6 blades installed the pitch adjustment is limited. It is recommended to experiment with numbers of 2, 3, 4, and 6 blades installed under various wind speeds and blade pitch settings.

If you have enough wind try reducing to 2 blades as you may get a little more power than using 3 blades. More blades installed will allow the turbine to start rotating more quickly under low wind conditions.

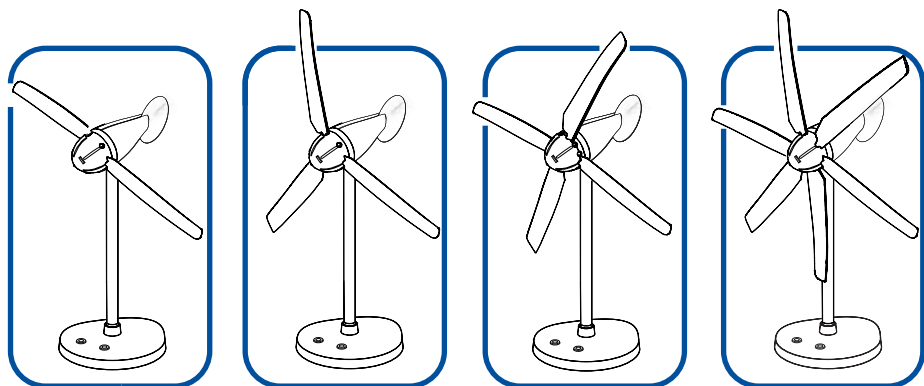

Your Wind Energy Kit is now ready for experimentation and be placed in line with an appropriate wind source.

Experiment 1. Using a Wind Turbine to Power the LED Module

Power the LED module by attaching the wind turbine's cables to their respective slots on the LED module base. Position turbine to directly face the direction of wind source.

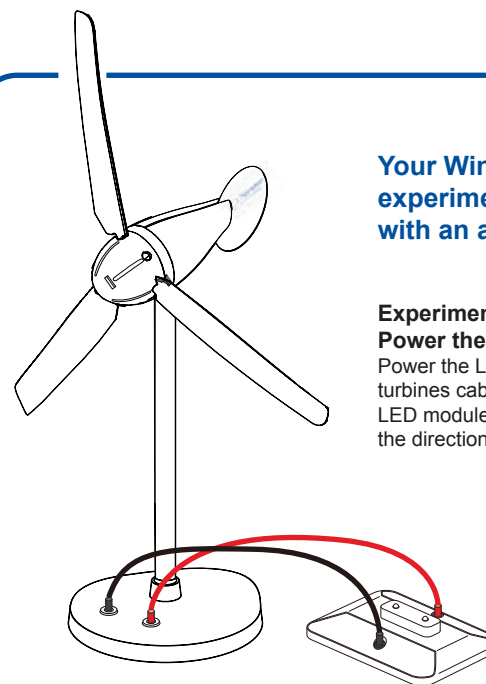

Experiment 2. Preparation of the Electrolyzer Module and Wind Powered Hydrogen Production (See next chapter Solar Energy for detailed assembly for H2 preparation)

Connect the red and black cables to the corresponding terminals located on the wind turbine and reversible fuel cell. For best results using the WindPitch to generate hydrogen using the included reversible fuel cell, setup the wind turbine hub with 3 profiled blades marked C supplied with the kit.

Set the blade pitch to 6 degrees. Make sure that the wind turbine is generating AT LEAST 2.5 volts. If not, move the wind turbine closer to the fan until it does. The wind turbine is sensitive to this setting at high wind speeds.

Allow the table fan and wind turbine to run for about 60 minutes on high wind speed setting to generate sufficient amounts of hydrogen and oxygen gases that are stored in the water/gas tanks.

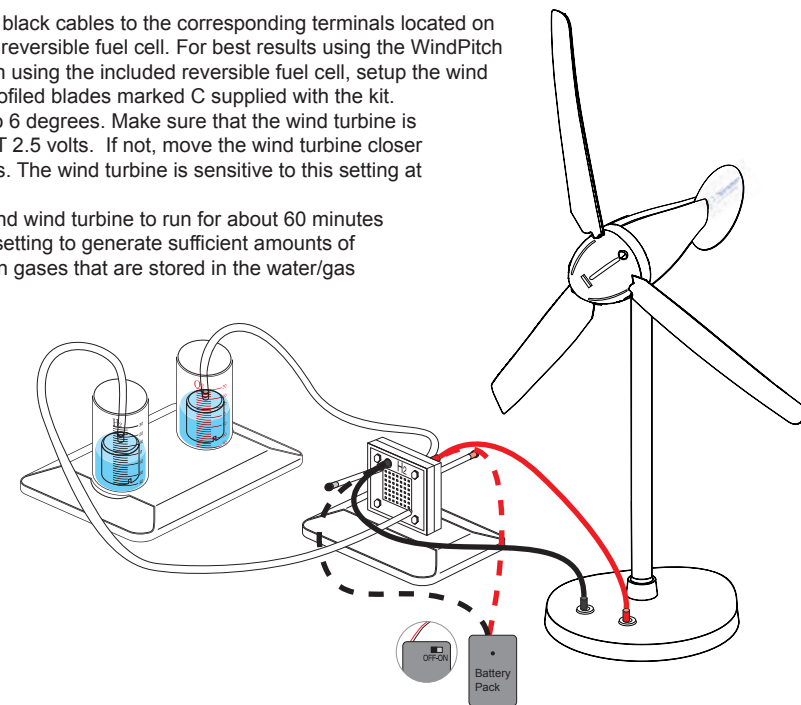

If the wind is sufficient the system will now start to produce hydrogen and oxygen in the respective cylinders. When bubbles begin to surface in the hydrogen cylinder the cycle is complete. Disconnect the reversible fuel cell from the Wind Turbine.

Procedure for repeated gas production: Disconnect the small plugs from the tubes connected to the nozzles on the reversible fuel cell. This will allow water into the inner cylinders to replace the gasses and reset water levels to "0" line. Re-insert the plugs into the tubes and repeat electrolysis again.

Note: You may also use the battery pack to perform electrolysis (In the case of no wind source)

(alternative): Using the Battery Pack to Perform Electrolysis (in the case of no wind)

Please remove the screw from cover of battery box using a screw driver. Push and slide the cover and open the battery box. Try NOT to touch the cables when you open the cover. Place two AA batteries as indicated. Push and slide the battery box cover to closed position and screw tightly into place using screw driver.

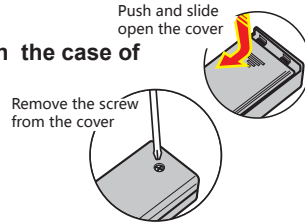

- ※ Make sure the switch on the battery box is in the "off" position before you place the batteries into the box.
- ※ **WARNING: If the cable is short circuited the batteries inside could become hot and potentially cause burns, melting of parts, or create risk of fire.**

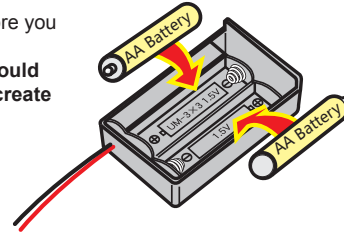

USING FUEL CELLS TO CONVERT HYDROGEN TO ELECTRICITY

Preparation of the Fuel Cell System

Insert the fuel cell into the base with the red terminal on the same side as the red terminals on the base. Connect a green purging valve to one end of a 2cm tube and the other end to the upper nozzle on the hydrogen side of the fuel cell.

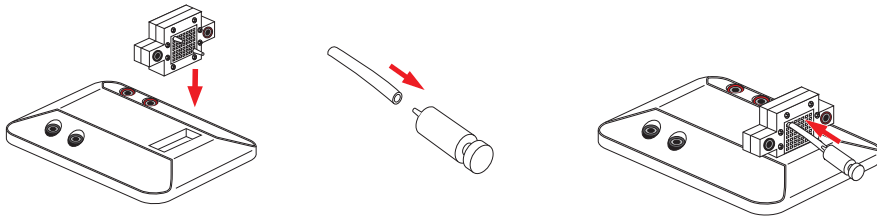

Clench the tube connected to the electrolyzer and hydrogen cylinder so that none of the hydrogen in the cylinder from the last experiment can escape. Next disconnect the tube from the electrolyzer and connect it to the lower nozzle on the fuel cell.



Experiment 3: Using a PEM Fuel Cell to Power the LED Module

Connect the fuel cell to the fuel cell base using the red and black wires. Make sure to connect the black wire with the black terminals and red with red terminals. Now connect the LED module to the base in the same manner.

You should see the LED lights begin flashing. If not, purge a very small amount out of the valve to allow some of the gas to move into the fuel cell. As the LED light consumes electricity the fuel cell will consume hydrogen from the cylinder and you will see the water level reflect the changes in amount of gases consumed.

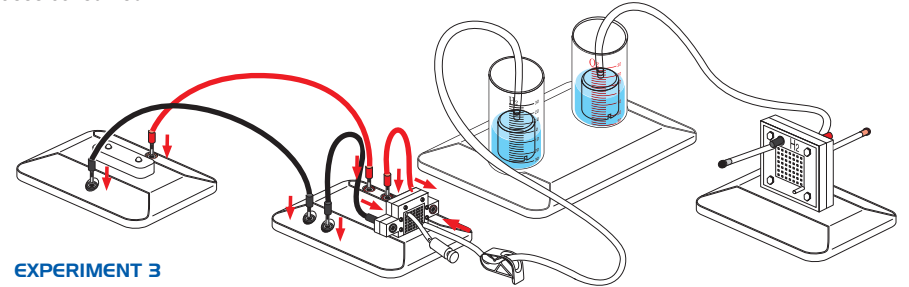

EXPERIMENT 3

1. Assembly of the small electric fan:

Connect small round white adapter to the motor axis. Connect the fan blade to the adapter.

2. Assembly of the car wheel:

Firmly connect the other (tapered) white adapter to the motor axis. Attach the small wheel to the adapter.

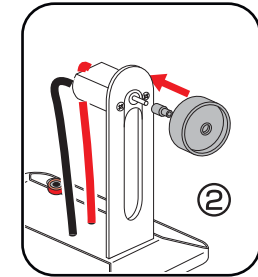
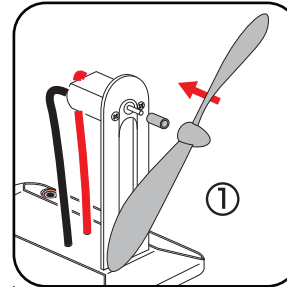

Experiment 4: Using a PEM Fuel Cell to Power the Small Electric Fan Module

Repeat the hydrogen production and fuel cell preparation steps.

Next, connect the small fan/wheel motor base to the fuel cell base to generate power to the motor.

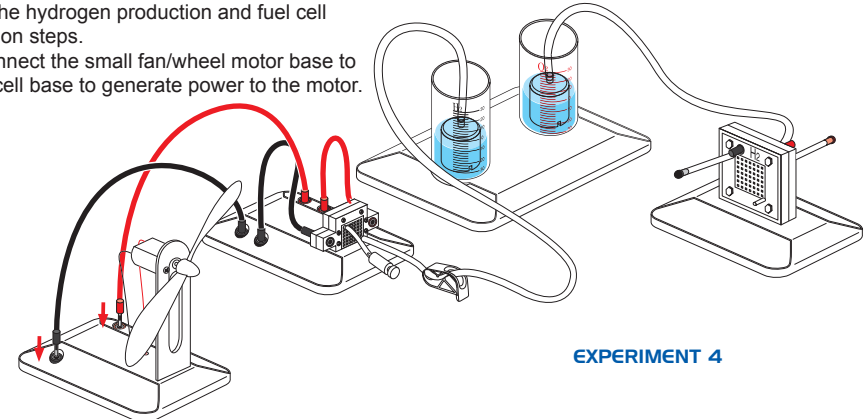

EXPERIMENT 4

Experiment 5: Using a PEM Fuel Cell to Power the Small Car Wheel Module

Repeat the hydrogen production and fuel cell preparation steps. Next, connect the small fan/wheel motor base to the fuel cell base to generate power to the motor.

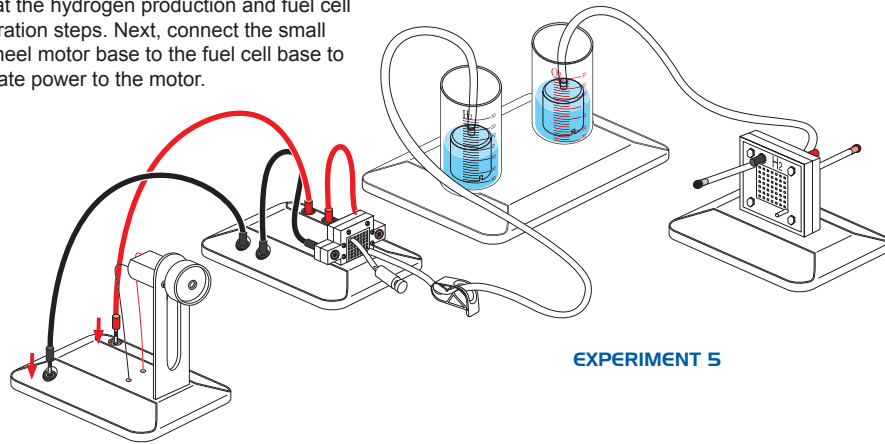

EXPERIMENT 5

Experiment 6: Using a PEM Fuel Cell to Power the Small Fan/Wheel Motor Module and the LED Module in Parallel

Repeat the hydrogen production and fuel cell preparation steps. Next, connect the small fan/wheel motor base and the LED module base to the circuit board. Then connect the circuit board to the fuel cell module base to generate power to both modules in parallel.

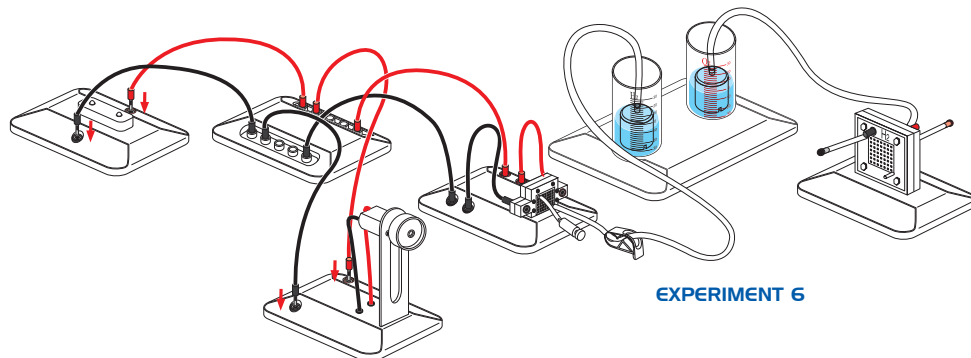

EXPERIMENT 6

Most commonly a floor or basic desk fan is the source of wind used for experimentation with the Wind Kit. A larger fan allows you to test the performance of the turbine at higher wind speeds. You can switch the fan to a lower setting or increase the distance between the fan and the turbine to achieve low wind speeds. It is difficult to achieve high wind speeds with a small fan. A fan of 16" diameter is suitable for doing most wind power experiments.

For optimum performance, align the centre of the fan with that of the nacelle of the turbine. Therefore, it will be better if the height of the fan is adjustable.

Wind from a natural source is never steady. Therefore, the output power of the turbine is always varying. This may lead to uncertainty in taking readings and measurements in the experiments. In order to reduce the variation of wind speed due to turbulence, operate the setup at the middle of a hall or use a wind tunnel. The wind speed will be more stable under these conditions.

With the included LED Module, wheel and fan blade module you can demonstrate the output power created by the Wind Kit and use this power to illuminate the LED Lights on the Module. You can use the Renewable Energy Monitor provided to measure the LED.

This LED Module, wheel and fan blade module is intended as a basic demonstration device. To perform much more detailed experiments and explore the full educational value of your Wind Kit refer to the educational CD. With the device and in combination with Horizon's PEM electrolyzers you can perform a multitude of experiments including:

Take your Wind Kit experimentation to the next level !

Listed below are additional wind experiments that can be performed with the Wind Kit wind turbine using a multimeter or with Horizon's Renewable Energy Monitor Lab and your computer.

- **Using Different Blade Shapes Create Power**
This experiment demonstrates how blades with different curvatures produce different degrees of power output. Wind turbine blades are shaped like airplane wings, and one size does not fit all requirements. You will measure and understand how using the right blade shape can produce optimum power for different wind conditions.
- **How Many Blades Are Best? 1, 2, 3, 4...**
Using the right number of blades for a given wind condition is important in extracting the maximum electrical power from a wind turbine. You will measure and understand the choices between the numbers of blades that are necessary to produce best results.
- **Adjusting Blade Pitch for Best Performance**
Angling the blades into and away from the wind are important elements in creating maximum power – or slowing the speed of rotation. This experiment will show you the techniques for stalling and furling as well as adjusting the blade pitch to extract the maximum degree of power from the wind.
- **How Much Power Can Be Extracted from the Wind**
While power from the wind is free as long as it blows, it is still limited to certain physical laws. This experiment will show you how to measure wind speed versus extracted wind power.
- **Using Wind Power to Generate Hydrogen**
One important use of wind power is to generate hydrogen in a clean, non-polluting manner. This experiment shows you exactly how to do it.
- **Measure Wind Turbine Performance Using RPM**
Using our electronic measurement tool you can measure the voltage, current, power and RPM (revolutions per minute) rotational speed of the wind turbine and see it displayed on the measurement tool as well as your computer. Watch the RPM as it changes with wind speed and resistor loading and witness how to slow down and even stop the wind turbine spinning without even touching it – just by adding the right resistor combinations. Make measurements for wind power and turbine efficiency to really understand how this remarkable device works.
- **Build a Wind Farm**
Arrange multiple Wind Kit turbines in series and parallel configurations in order to study the voltage, current, and power generated. Design a simulation of a commercial wind farm in model scale and learn the potential of wind power as a mass energy source.

Purchase additional Wind Energy Kits and Circuit Board Module Base and red/black hookup leads needed to connect multiple turbines in series and parallel here-
<http://www.horizonfuelcell.com/store.htm>

Safety

Before you proceed to perform experiments with the turbine, please note that the rotor can rotate at a few thousand RPM's (Rotations per Minute), especially when no load is connected. When the wind speed is high and the turbine is set to output high power, the rotating speed of the rotor can also be very fast. Bodily injury may result if struck by the rotating blades. Wearing goggles is suggested in the case that your head will be close to the rotating blades. You should also install the turbine properly so that it will not "walk" or topple over. The weight of the base has been increased from previous versions to prevent the turbine from "walking". Placing a rubber mat, polyfoam, or a thin book under the base helps stabilize the turbine if the surface of the table is too hard. In the case that the turbine topples at high rotational speed, to avoid being hurt, do not try to catch it. Arranging the wires from the turbine to run inside the aluminium tube through the opening on the post and base prevents the wires from tangling by the rotating blades. All of the above measures help to reduce accidents during operation of the turbine. However, you have to make sure that the environment is safe for doing experiments. Adult supervision is required. This wind turbine is not suitable for children under 14 years old.

Troubleshooting

- The water levels do not drop when the gas outlet tubes on both sides of the fuel cell are unplugged.
Solution:
Check whether the holes on the wall of the inner container are blocked. If so, turn the inner container until water enters the holes and fills up the inner container.
- The electrolyzer does not produce hydrogen and/or oxygen.
Solution 1:
Check whether the wires are appropriately connected, and whether there are any loose connections. The fuel cell could be completely destroyed if the red wire of the battery pack is connected to the black jack of the fuel cell.
Solution 2:
Replace the old batteries with new one in the battery pack.
- The load cannot work while there is hydrogen left in the inner container.
Solution:
Push the green purging valve to release tiny amount of hydrogen. You can then observe the load working well again.
- The water electrolysis process slows down.
Solution:
Inject water to the oxygen side of the fuel cell by using the syringe and wait for about 3 minutes before using the electrolyzer again.
- No hydrogen is produced using the windturbine outdoors.
Solution:
If the wind speed is not sufficient electricity will not be created. Use a common desk fan with faster wind speed to perform the electrolysis using the electrolyzer, or conduct the experiment under stronger wind conditions.
- The fuel cell can not generate electricity while there is hydrogen still left in the hydrogen container.
Solution 1:
Push the purging valve to release remaining amounts of hydrogen.
Solution 2:
Use the syringe to clear the water out of the fuel cell.

Solar Energy

What you need:

- Electrolyzer fuel cell
- Mini fuel cell
- Battery pack
- Solar panel
- LED module
- Water & Hydrogen tank
- Water & Oxygen tank
- Clamp
- Wheel
- Purging valve
- Heavy fan module
- Fan blade
- Water tank base
- Reversible fuel cell base
- wires
- Syringe
- Silicon tubes
- Mini fuel cell base
- Red & black pins
- Fan & wheel adapter
- Circuit board

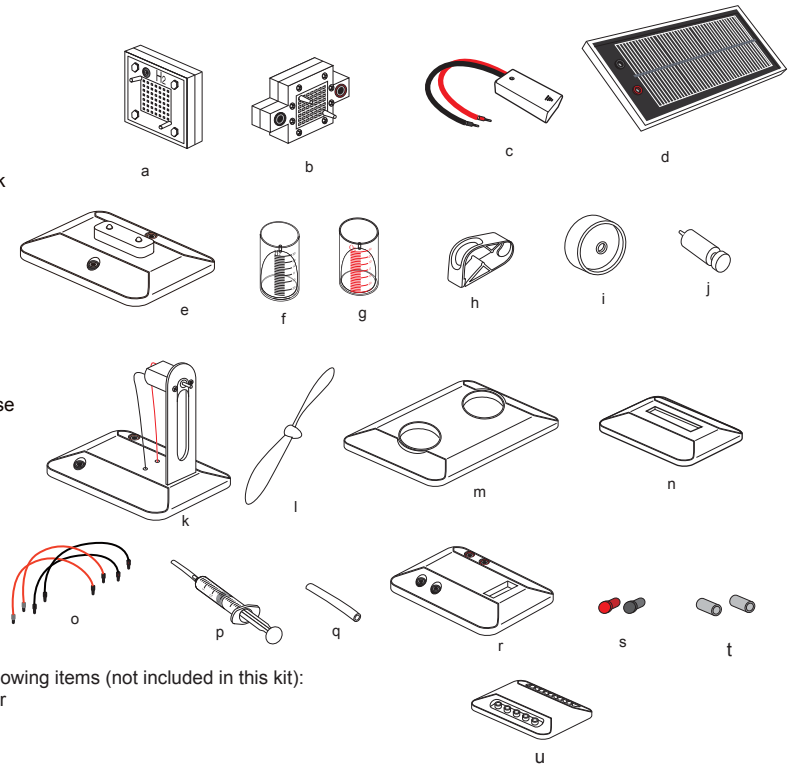

You will also need the following items (not included in this kit):
 - Purified or distilled water
 - AA batteries
 - Scissors

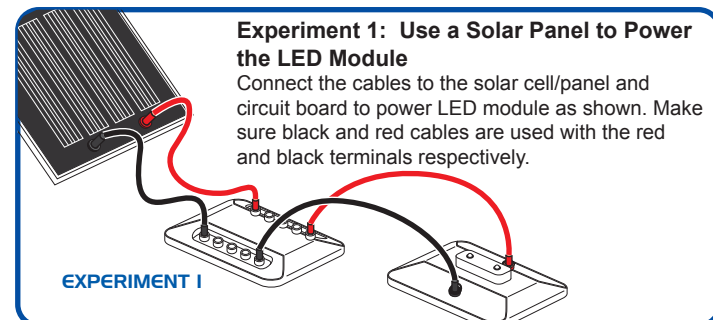

Experiment 2: Use a Solar Panel to Power the Small Fan/Wheel Motor Module

1. Assembly of the small electric fan:

Connect small round white adapter to the motor axis. Connect the fan blade to the adapter.

2. Assembly of the car wheel:

Firmly connect the other (tapered) white adapter to the motor axis. Attach the small wheel to the adapter.

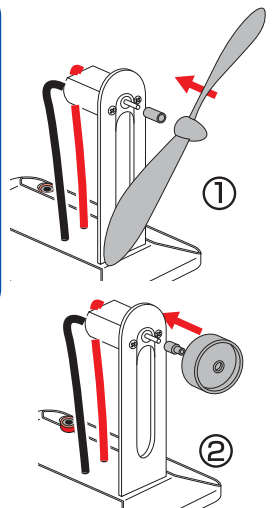

EXPERIMENT 2

3. Connect the solar panel to the circuit board then to the motor base as shown. The fan may need to be flicked with your finger to start.

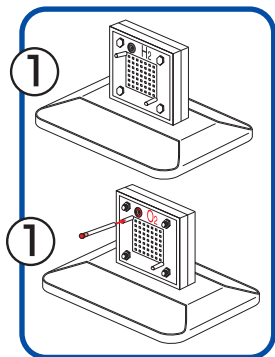
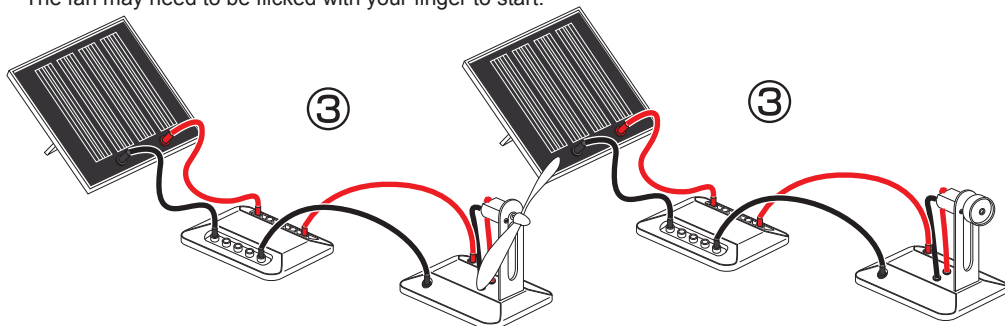

Experiment 3: Preparation of the Electrolyzer Module and Solar Powered Hydrogen Production

1. Insert the electrolyzer, terminals on top, into the slot on the base. Cut 2 x 4cm length pieces of rubber tube and insert a black pin into the end of one tube. Place the tube with the black pin into the top pin on the hydrogen side (with black terminal). Place the other tube firmly onto the top input nozzle on the oxygen side.

2. Fill the syringe with DISTILLED water. On the red oxygen side of the electrolyzer, connect the syringe to the uncapped tube. Fill the electrolyzer until water begins to flow out of the tube. Attach a red plug to the Oxygen side tube. Let settle for 3 min.

3. Attach the round cylinders to the cylinder base by pressing downward into round slots and twisting into place. Then add water up to the "0" line.

4. Cut out a 20cm length tube. Place it through the holes on the white clincher, with the clincher 4 cm from the end of the tube.

5. Place inner containers into outer cylinders minding that the gaps are not blocked by inner plastic rims. Make sure the water is still level to the "0" line. If not, remove some water with the syringe so that water level is at "0" line. Connect the tubings to the top nozzles on the inner containers. If the tubing is connected to the inner cylinders last there will be no air trapped inside the inner containers.

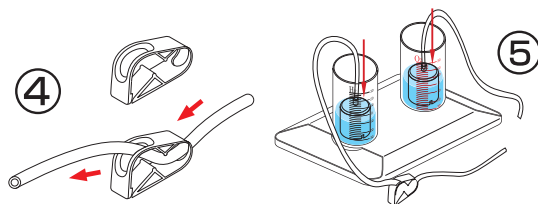
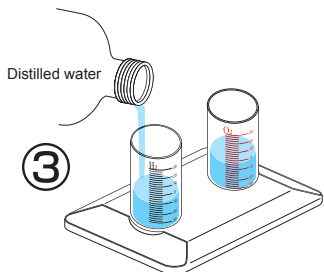
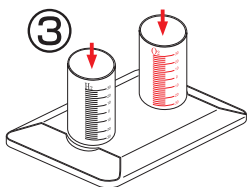
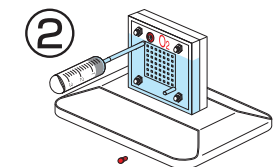

EXPERIMENT 3

6. Connect the other end of the tube to the bottom end of the black hydrogen side of the electrolyzer. Connect the other end of the tube to the bottom end of the red oxygen side of the electrolyzer.
7. Connect the electrolyzer to the solar panel using the corresponding cables and expose to direct sunlight. Or connect the battery pack (with battery in) to the electrolyzer and turn it on. (Important: make sure connections are correct or permanent damage can occur. Make sure the clincher is OPEN.)
The system will now start to produce oxygen and hydrogen in the respective cylinders. When bubbles begin to surface in the hydrogen cylinder the cycle is complete. Disconnect the electrolyzer.
Procedure for repeated gas production: Disconnect the small plugs from the tubes connected to the nozzles on the electrolyzer. This will allow water into the inner cylinders to replace the gasses and reset water levels to "0" line. Re-insert the plugs into the tubes and repeat electrolysis again.

Using the Battery Pack to Perform Electrolysis (in the case of no sun)

Please remove the screw from cover of battery box using a screw driver. Push and slide the cover and open the battery box. Try NOT to touch the cables when you open the cover. Place two AA batteries as indicated. Push and slide the battery box cover to closed position and screw tightly into place using screw driver.

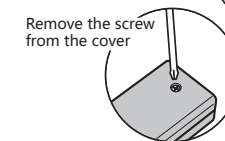

- ※ Make sure the switch on the battery box is in the "off" position before you place the batteries into the box.
- ※ WARNING: If the cable is short circuited the batteries inside could become hot and potentially cause burns, melting of parts, or create risk of fire.
- ※ Note: Battery's energy may be consumed after 4-5 times of use.
- ※ Make sure to connect the black cable to the black plug, the red cable to the red plug on the fuel cell.

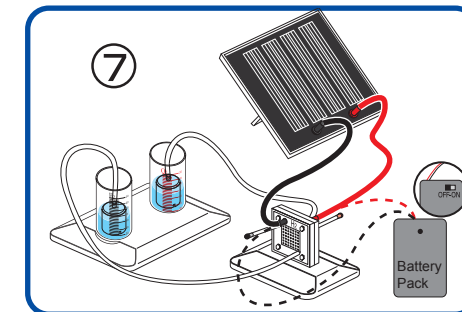
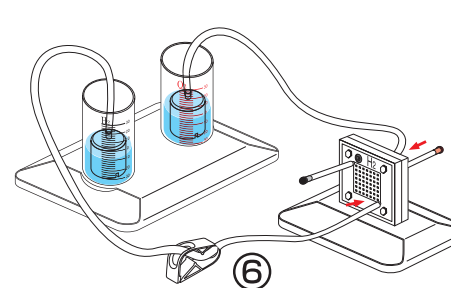
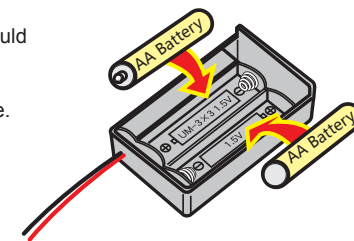

As soon as the electrolysis is completed, you can use the energy contained in the hydrogen tank to power other systems. Please refer to the experiment 3-6 in Wind Energy chapter.

Troubleshooting

1. The water levels do not drop when the gas outlet tubes on both sides of the reversible fuel cell are unplugged.

Solution:

Check whether the holes on the wall of the inner cylinder are blocked. If so, turn the inner cylinder until water enters the holes and fills up the inner cylinder.

2. The reversible fuel cell does not produce hydrogen and/or oxygen.

Solution 1:

Check whether the wires are appropriately connected, and whether there are any loose connections. The reversible fuel cell could be completely destroyed if the red wire of the battery pack is connected to the black jack of the reversible fuel cell.

Solution 2:

Make sure the batteries are inserted with the correct polarity.

Solution 3:

Replace the old batteries with new one in the battery pack.

3. The water electrolysis process slows down.

Solution 1:

Inject water to the oxygen side of the reversible fuel cell by using the syringe and wait for about 3 minutes.

Solution 2:

Replace the old batteries with new one in the battery pack.

4. The motor does not run while there is hydrogen left in the inner container.

Solution:

Unplug the black pin of the short tube on the reversible fuel cell and quickly attach the pin back to the tube to purge out impure gases. You should then see the motor begin to turn again.

5. No hydrogen is produced under the sunlight.

Solution:

If the sunlight is not strong enough electricity will not be created. Use the battery pack provided to perform the electrolysis using the reversible fuel cell.

Bio-Energy

What you need:

- a. Fuel cell module
- b. Fuel solution container
- c. Fuel tank with lid
- d. Fan module
- e. Fan blade
- f. Silicon tubes
- g. Clamp
- h. Wires
- i. PH paper
- j. Syringe

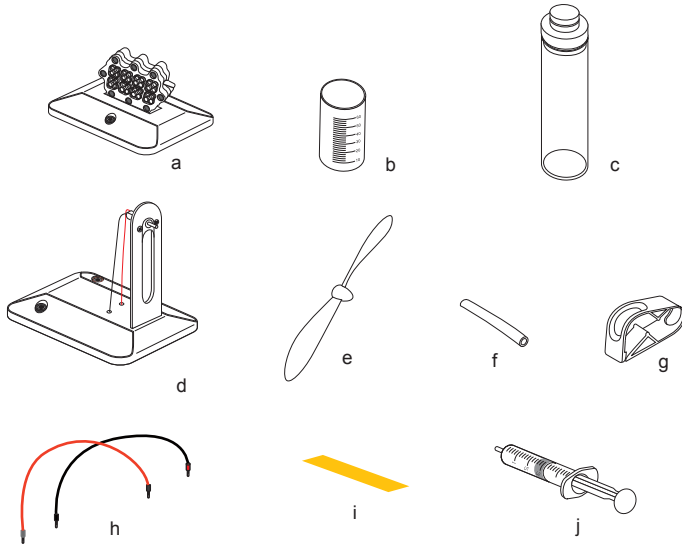

You will also need the following items (not included in this kit):

- Purified or distilled water
- Ethanol
- Scissors

Preparing a 10% ethanol solution:

WARNING:

DO NOT mix the fuel solution in the fuel tank (c), otherwise the fuel tank could be easily damaged.

Do not pour pure ethanol in the fuel container (b). The DEFC creates power using 5-15% alcohol only. A concentration higher than 15% could damage the fuel cell and make it stop working. In order to obtain the best performance please use a mixture of 10% ethanol and 90% purified or distilled water. Keep ethanol away from the fire or flame source while you are mixing the solution. Igniting the ethanol and the ethanol solution is strongly forbidden.

Step 1: Fill the solution container (b) with 10ml of pure ethanol (fill container to the 10ml level).

Step 2: Fill the remainder of the container with water to the 60ml level.

Step 3: Stir the liquid in the container thoroughly.

Experiment 1: Create electricity from ethanol and water

Step 1: Cut one 15cm long tube and put it through the plastic clamp,

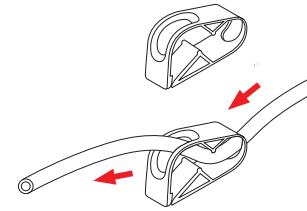

Step 2: Connect the tube to the fuel tank (c) and close the clamp.

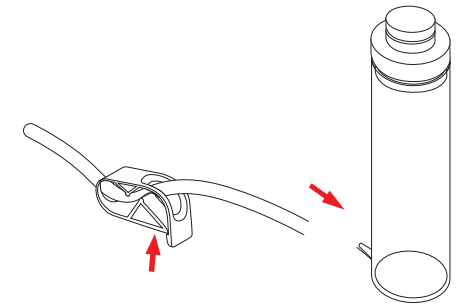

Step 3: Connect the other end of the tube to the fuel cell lower fuel inlet. Make sure the connection is tight. Cut a 10cm long tube and connect it to the other outlet of the fuel cell (the remaining nozzle).

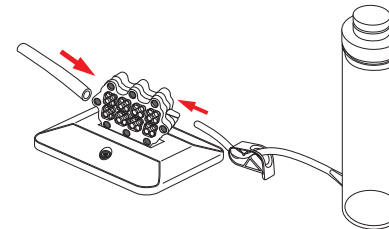

Step 4: Pour the fuel solution into the fuel tank (c). Put the lid back to the tank.

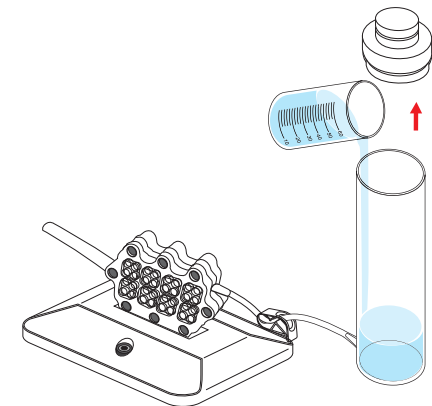

Step 5: Remove the fan blade from the box. Push the blade onto the axis of the motor slowly and carefully.

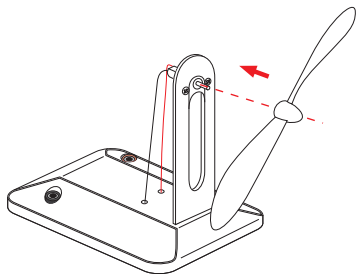

Step 6: Use the wires to connect the fuel cell module to the fan module. Make sure you respect the color code when you plug wires into the sockets.

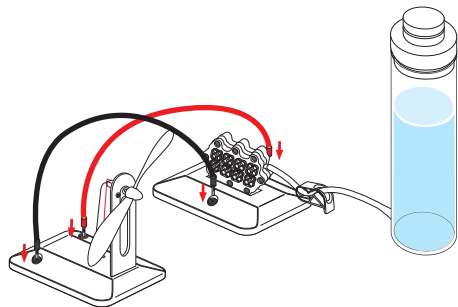

Step 7: Open the clamp. You can notice the liquid flows out of the tube through the fuel cell. Once you see the liquid flows out of the tube, close the clamp. Wait for 5-10 minutes, you will notice the fan starts to rotate.

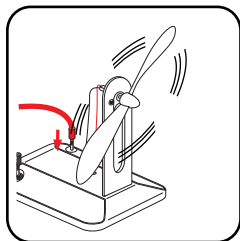

Notes: Once the fan stops rotating, open the clamp to purge some solution out of the fuel cell and close the clamp. Wait for 5-10 minutes, the fan should start rotating by itself once connected. If the fan does not run at this time, it may need to be flicked with your finger to start. Make sure you repeat the waiting period of 5-10 minutes after each purging. Since the reaction is slow, the fan can run for up to several hours without purging.

IMPORTANT NOTES:

After the first use of the fuel cell, you have to cut a 2 cm long tube on the remaining tube and to connect this one to the syringe. You will use it to clean the system after every use of the product.

After each usage, you have to fill the syringe with purified water. Then, remove the fuel inlet tube and replace it by the syringe tube. Inject the water into the fuel chamber to flush out the methanol solution out of the system. Disconnect the syringe and fill it with some air. Make the connection again and inject the air into the system in order to completely purge the remaining water out. The fuel cell then could be stored until the next use.

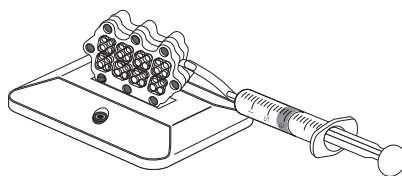

Experiment 2: Exploring polarity

Step 1: Connect the red cable to the red socket of fuel cell and the fan module.

You will notice the fan will turn clockwise.

Step 2: Now repeat the process, this time however connect the red socket of the fan module into the fuel cell black one. You will notice the fan will turn counter-clockwise.

Conclusion: The current flows from positive to negative, creating a clockwise spin of the fan. By inverting the polarity connections, the current flow reverses and makes the fan spin in the opposite direction.

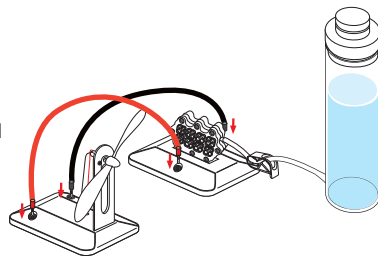

Experiment 3: Ethanol fuel consumption

When the fan begins to run slower or stops running completely, this means the ethanol present in the fuel cell chamber is mostly consumed. In normal temperature conditions, the majority of the ethanol inside the fuel cell chamber turns into acetic acid, which is the main component of vinegar.

Let's investigate the consumed fuel (acetic acid) when the fan begins to run slowly.

Step 1: Place a piece of PH paper under the outlet of the outlet tube.

Step 2: Open the clamp slowly, and release drops of the solution onto the pH paper, and then close the clamp. You can see the paper color changing to a reddish color quickly.

Step 3: Dip a new pH paper into the solution container. You will notice that the color of the PH paper changes very little.

The difference in pH paper coloring indicates the change of the acidity level. Ethanol turns into acetic acid during the reaction taking place at anode side of the fuel cell, and the pH of the solution noticeably changes from pH level 6 to pH level 2 showing a red color. The chemical reactions taking place at the anode showing that acetic acid is formed as hydrogen protons depart from the ethanol molecule and the water molecule. These hydrogen protons cross the fuel cell membrane, and the liberated electrons form the electricity that is able to propel the fan.

Conclusion: The Direct Ethanol Fuel Cell creates electricity by chemically converting the ethanol solution into an acid solution, which is close to common vinegar. In order to obtain a continuous functioning of the fan, "spent" fuel must be replaced with new fuel regularly.

Experiment 4: Exploring the effect of varying fuel concentrations

You can make the different concentrations of ethanol fuel in the initial mix. For a 15% solution, add 9 ml of pure ethanol and fill water to the level of 60 ml. You can use a multi-meter or Horizon's REM product ref. FCJJ-24 to measure the voltage difference produced by the fuel cell. Through experimentation, you will find that increasing or decreasing the concentration of the Ethanol does not noticeably make the fan run faster.

The reason for this is that the capability of the catalyst used on proton exchange membrane in the fuel cell is limited. Similarly to many people going through a narrow door, the speed of people going through the door is determined by the width of the door, but not by the amount of people.

Warning: The safe experimentation range for the this Kit is within ethanol concentrations ranging from 5-15%. Please note that the concentration cannot be higher than 15-20% otherwise it will permanently damage the fuel cell.

Tip: If the device will not be used for more than one day, first open the clamp to purge out all solution in the fuel cell and pour purified or distilled water in the fuel tank. Make sure all of the purified or distilled water flows out of the fuel tank. Do not let the solution stay in the fuel cell otherwise it will damage the fuel cell.

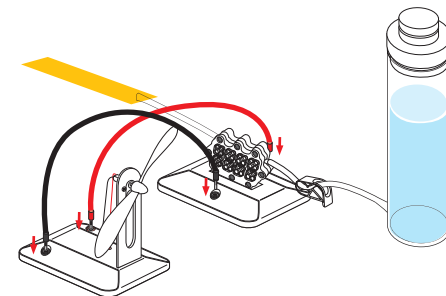

Experiment 5: Create electricity from wine or beer

Try using different types of alcohol such as wines made from grapes or rice instead of the ethanol/water solution.

Follow up the steps in the experiment 1: create electricity from ethanol and water to create electricity.

WARNING:

1. Alcohols used should stay within the range of 5-15% alcohol. If you are using an alcohol that has a higher concentration than 20% please mix the adequate amount of water into the alcohol to keep the required concentration range of 5-15%.

2. Using impure ethanol can damage the performance of the fuel cell. You may want to conduct experiments using impure ethanol once all other experiments using pure ethanol are completed.

When you have finished all the steps as in experiment 1, you may notice the fan may run very slowly, or may not run. When using different alcohol types, this can affect performance. This has to do with the purity of the solution, since some alcohols such as wine contain elements that can clog the membrane on the fuel cell, limiting its permeability. Use a multi-meter or Horizon's REM ref. FCJJ-24 to measure the voltage or current produced by the fuel cell under various conditions and slowing the speed of the chemical reaction.

See experiment 6: You will be able to prove that at different temperature conditions, different voltages are produced, and you can plot these results into a chart to determine the optimal temperature conditions for the fuel cell to generate the best results for each kind of alcohol you use.

Experiment 6: Exploring the effects of temperature.

Note: Before you blow warm air towards the fuel cell, feel the air temperature with your hand first to make sure the air is not too hot (temperature under 60°C are preferred).

Step 1: Use a hair drier to blow warm air towards each side of the fuel cell or place a warmer ethanol/water solution into the fuel tank. You will observe that the motor and fan will be operating at a faster speed.

Step 2: Use a multi-meter or Horizon's fuel cell software adaptor product ref. FCJJ-24 to measure the voltage produced by the fuel cell. You will be able to test that at different temperature conditions, different voltages are produced, and you can plot these results into a chart to determine the optimal temperature conditions for the fuel cell.

At higher temperatures, atoms tend to move faster and are more likely to interact with the catalysts located on the surface of the membrane. With more interactions, the reaction accelerates and more electricity can be produced, which means the fan starts to turn faster.

Conclusions:

- (1) Higher temperature will make it more likely for ethanol molecules to interact with the catalysts located on the surface of the membrane, which accelerates the speed of the chemical reaction.
- (2) High temperature can also make the membrane more active, so it will demonstrate an increased ability of proton exchange within the membrane and an increase the speed of the fan motor. Increasing the power capability of ethanol fuel cells can be done by increasing their operating temperature, or the temperature of their fuel.

Troubleshooting

A. The fan begins to run slower or stops running completely

Solution:

a. Disconnect the fuel cell module from any load. Place the outlet tube above a container or suitable receptacle. Open the clamp to let a few drops of acetic acid flow out, allowing the mixture of the fresh ethanol solution to re-enter the fuel cell.

b. If the solution level is too low in the fuel tank and it can not flow into the fuel cell chamber, mix new solution and pour it into the tank to reach proper level. Or you can lift the fuel tank up to make the solution level in the tank higher than the inlet nozzle on the fuel cell.

d. Wait for 5-10 minutes before reconnecting the loads to the fuel cell. Once reconnected, watch the fan start rotating again at constant speed. The fuel cell is able to start the reaction once more (and more hydrogen protons can permeate through the membrane).

B. After all the wires and tubes have been connected, the fan still cannot run.

Solution:

a. Make sure that the red and black wires are connected correctly.

b. Make sure that the tube from the fuel tank is well connected to the fuel cell inlet.

c. Make sure there is enough ethanol solution to circulate into the fuel cell and that the tubing is not blocked.

C. I opened the clamp, but no solution flows out of the tube.

Solution:

a. Add fresh fuel solution to the fuel tank.

b. Lift the fuel tank up to make the solution level in the tank higher than the inlet nozzle on the fuel cell.

Mechanical Energy

What do you need:

- a. Hand crank generator
- b. Potentiometer
- c. Super capacitor
- d. Heavy fan module
- e. Fan blade
- f. Capacitor base
- g. Capacitor support
- h. Wires
- i. Fan blade adapter

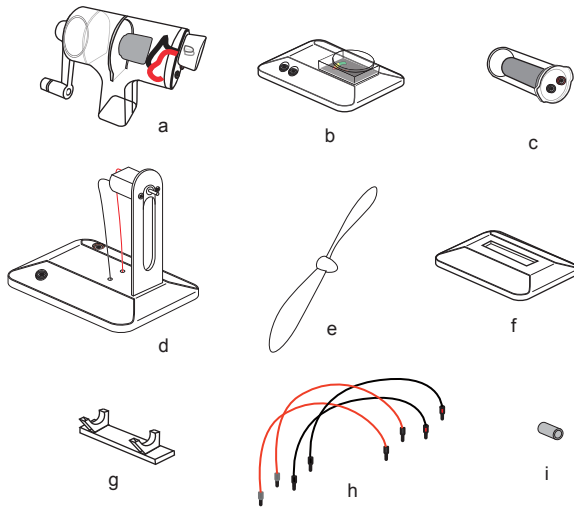

Step 1. Preparing the super capacitor module

a. Insert the super capacitor support (g) into the base (f).
Make sure they fit well.

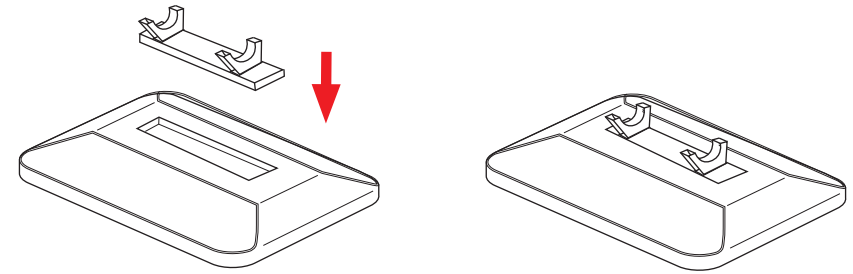

b. Place the super capacitor (c) onto its support (g).
Make sure the capacitor fits well in its support.

c. Plug the red cable (h) and black cable (h) in the capacitor red and black socket.
Ensure to respect the color code.
Otherwise energy from the hand crank can not be stored into the capacitor.

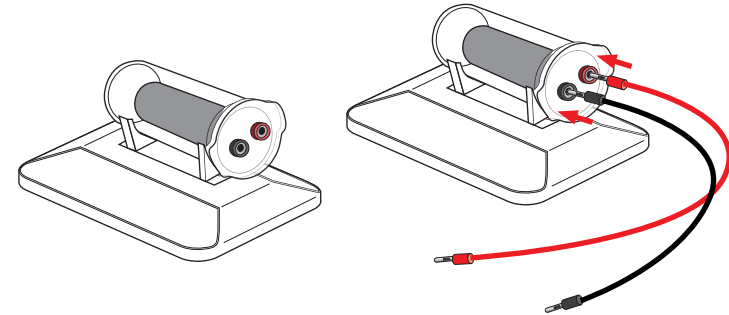

Step 2. Preparing the energy storing kit

a. Connect the other end of the cable to the potentiometer (b).
Ensure to respect the color code.

b. Connect the red and black cable to the hand crank (a).
Ensure to respect the color code.

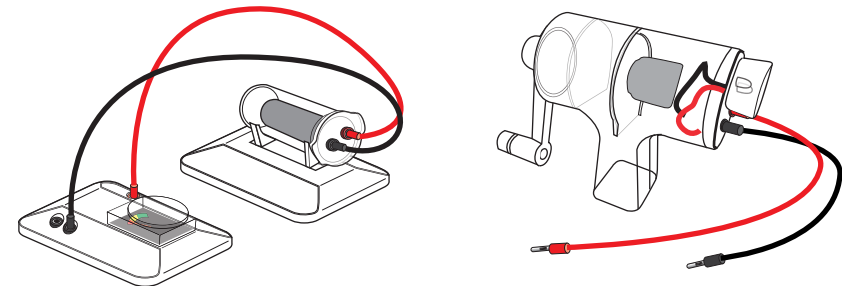

c. Connect the other end of the cable from the hand crank generator to the potentiometer. Ensure to respect the color code.

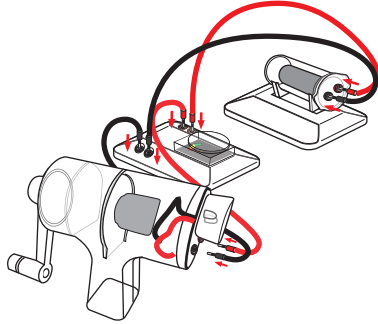

Step 3. Energy generating and storing

a. Firmly grasp the rotary handle of the hand crank generator with one hand and grip the main handle with the other hand.

b. Rotate the arm clockwise to generate power for charging the capacitor. You should crank the arm to reach a speed of two revolutions per second. Initially you will feel some resistance, which will become smaller after a few seconds. If you feel the resistance increase again, it means you've slowed down and need to speed back up.

Note: At the same time you can notice the potentiometer is moving towards green part, which means you are generating energy and the energy is being stored in the super capacitor.

WARNING: You are not allowed to rotate the arm anti-clockwise to charge the super capacitor. Otherwise the super capacitor will be damaged by the countercurrent.

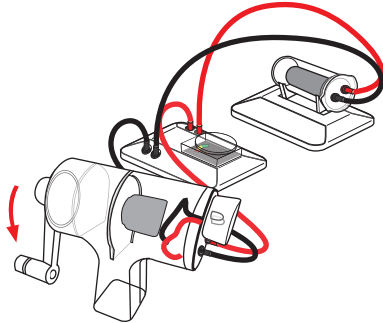

Step 4. Power the electrical fan with the energy stored in the capacitor

a. Connect the adapter (i) to the motor axis. Put the fan blade (e) onto the adapter. Make sure the fan blade is connected tightly to the motor shaft.

b. Use a cable to connect the fan module to the capacitor module. Ensure to respect the color code. Once they are connected, the fan moves fast immediately.

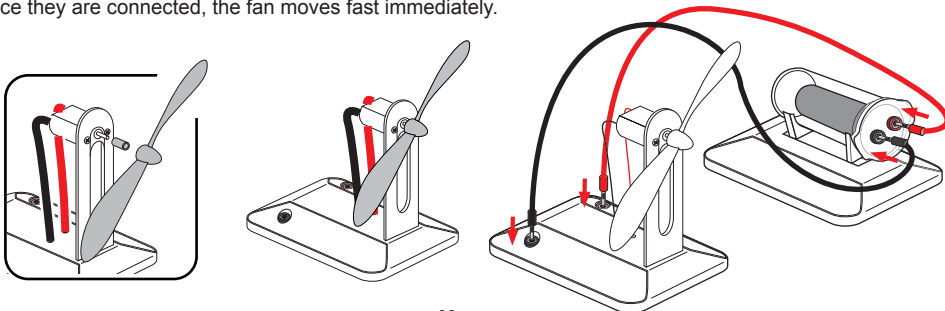

Step 5. Power the electrical fan directly with the hand crank generator

After connecting the wires, rotate the arm in a circular motion to generate power. You should crank the arm to reach a speed of two revolutions per second, fast is better. Initially you will feel some resistance, which will become smaller after a few seconds. If you feel the resistance increase again, it means you've slowed down and need to speed back up.

WARNING: DO NOT crank the arm too fast otherwise the hand crank generator could be easily broken by the strong force.

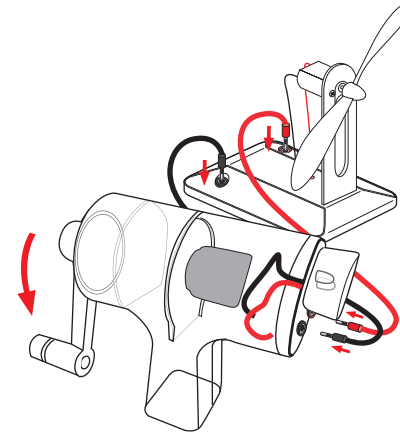

Note:

Finding the appropriate speed and technique will take a little practice. After you have spent a little time acclimating yourself to the hand crank generator, you should develop an easy rhythm that is not strenuous to sustain.

Although the generator is easy to crank, you may eventually tire. When you find yourself slowing down, stop and take a rest, cranking slower is harder and may not generate enough power to charge the capacitor or power the load.

The generator can be cranked in either direction, with either hand.

Try to rotate your hands around each other instead of trying to hold the generator still and moving one hand in a circle. This prevents one arm from tiring faster than the other.

Experiment with what works best for you. As long as the handle is cranked at approximately 2 revolutions per second the generator it will produce enough power to power the device provided.

ADVANTAGES of a Hand Crank Generator:

- Does not require solar, wind, or fuel to charge. Charge it anytime, anywhere!
- Does not require additional purchases of fuel during an emergency, when gasoline is scarce.
- Can be operated indoors without deadly fumes or threat of theft while outdoors.
- Easy to operate. Even children can safely operate the hand crank generator.
- Silent operation. No loud generator noise!
- Easy to set up. No confusing mounting or home alterations needed.

Conduct dozens of exciting, hands-on experiments with the science kit

Ideal as a battery replacement for a wide variety of basic electricity experiments, the hand crank generator is a low voltage power source that lets you create electrical current by simply turning a crank. This ingenious device generates student interest producing electrical energy through hands-on student effort. Student's enthusiasm is immediate, whether they are third graders lighting a bulb or college students reviewing sophisticated principles such as Ohm's Law or the electromagnetic properties of light.

Made from a sturdy, see-through ABS resin with nylon-plastic gears and handle, the kit is designed to shrug off use and abuse. It produces approximately 200mA of usable current. It is capable of producing up to 6 volts. You can reverse polarity by simply cranking the handle in the opposite direction. And, when powered by another kit or low voltage power source, it acts as a motor.

Activities and uses

Some of the activities require accessories sold separately. You can study electron flow, parallel and series circuits, Ohm's Law, motors and generators, energy transformations, and more.

Below is an activity for the kit:

Using a cellophane tap, wrap two wires onto a compass. Ensure you wrap the wires in the compass needle axis. Connect the other end of the wires to the hand crank generator. Turn the handle clockwise with different velocities. Do the same counter-clockwise. Does the deflection angle is linked to the handle angular velocity? Does the deflection angle is linked with the handle sense of rotation? Explain.

Repeat the above experiment exactly, but rotate the generator counterclockwise. What is the result?

Elementary and Middle School

Electricity in circuits can produce light, heat, sound, and magnetic effects. Electrical circuits require a complete loop through which current can pass. Use electric currents to create magnetic fields. Students know the role of electromagnets in the construction of electric motors, electric generators, and simple devices, such as doorbells and earphones. Describe electron flow in simple circuits. Students know how to design and build simple series and parallel circuits by using components such as wires, batteries, and bulbs.

High School

Energy is a property of many substances and is associated with heat, light, electricity, mechanical motion, sound, nuclei, and the nature of a chemical. Energy is transferred in many ways. The total energy of the universe is constant. Energy can be transferred by collisions in chemical and nuclear reactions, by light waves and other radiations, and in many other ways. However, it can never be destroyed. As these transfers occur, the matter involved becomes steadily less ordered. Electricity and magnetism are two aspects of a single electromagnetic force. Moving electric charges produce magnetic forces, and moving magnets produce electric forces. These effects help students to understand electric motors and generators. Measure the thermal and electrical conductivity of various materials and explain results. Analyze the relationship between an electric current and the strength of its magnetic field using simple electromagnets. Investigate and compare series and parallel circuits.

FAQ

What is a capacitor, how does it work ?

A capacitor is an electrical component which is composed of two plates separated by an electrical insulation. This component could function in two modes, the charge and the discharge. The charge occurs when there is a difference of potential across the conductors. It permit to store energy inside the generated electric field. In general, this kind of component is used for blocking the direct current and for letting pass the alternative one. They could be used to stabilize the voltage and the power flow in an electric power transmission.

What is a hand crank generator:

A hand crank generator is an engine which is used as a generator. It turns a mechanical energy into an electrical current. It is composed of three principal components which are the stator, the rotor and a rotary handle. The user will turn the rotary handle which will make turn a magnet inside a coil. Due to the rotation of the magnet, the electrical field turn and an electrical current will appear in the coil.

What will happen if I turn the hand crank handle in the wrong sense.

The hand crank generator could function in both senses as a lot of engine. The sense of rotation will just impact the sense of the current which is generated. However, you should be careful with the components which are connected to the generator. In fact, some components are polarized and they couldn't works in both sense.

What will happen if I connect the hand crank generator to the fan in the wrong sense?

Nothing bad, the fan is composed of a small engine which work in the same way than the generator but in the other sense (it turns an electrical current into a mechanical motion). If you pug the generator wires in the wrong sense, the fan will turn in the other sense than previously.

Do there is a special position to plug the generator to the potentiometer?

There is just one thing to know when you use a potentiometer, it should be wired in parallel with the component you want to measure the voltage.

What will happen if I connect the hand crank generator to the capacitor in the wrong sense?

You will damage seriously the capacitor if you turn the handle when the wires are incorrectly plugged into the capacitor. In this way, you risk to break or crack the capacitor. Warning, if you connect the capacitor in the good way but you turn the hand crank generator handle in the wrong sense, you also risk to break the capacitor.

Troubleshooting

1. The bulb light on the hand crank generator does not work when I rotate the arm. Replace the bulb light. It could have been damaged by long time using.
2. The fan does not run when I rotate the arm and all the connections are correct. Please tap the fan blade with your finger to help it start.

Thermal Energy

What you need:

- a. LED module
- b. Water tank base
- c. Water tank seals
- d. Fan module
- e. Fan blade
- f. Thermoelectrical system
- g. Thermometers
- h. Wires
- i. REM
- j. REM USB cable

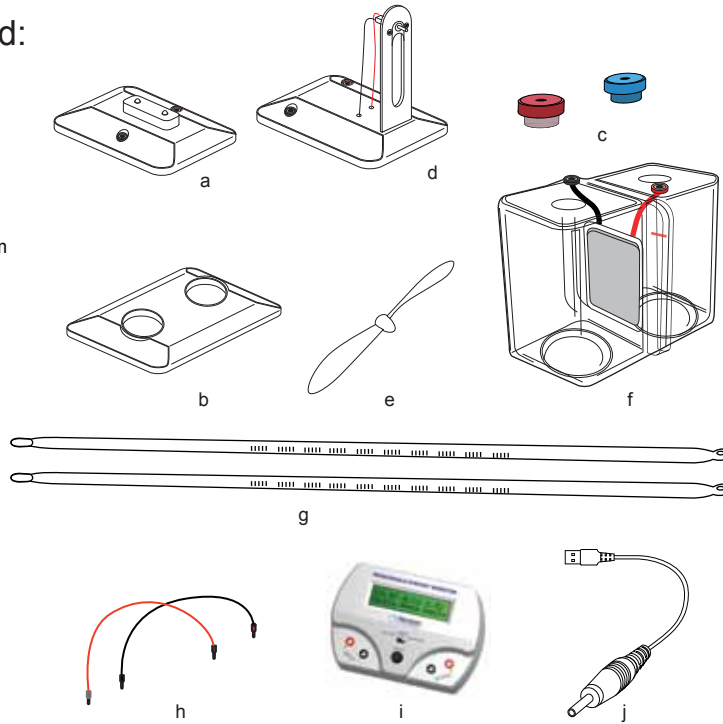

You will also need the following items for various experiments (not included in this kit):

- Purified or distilled hot (above 85°C) and cold (below 10° C) water
- Water containers
- Boiler
- Ice cubes
- 0 - 2 A ; 0 - 4 V electrical generator
- Two K-type thermocouple

IMPORTANT NOTES:

1. Take care with the hot water to not hurt yourself.
2. Wearing waterproof gloves and glasses are highly recommended
3. There is a risk of being burned by the hot water.
4. Thermometers are fragile and if you break them, there is a risk of personal serious injury.

Prepare the water

In the first container, put water and ice cube. Use the boiler to obtain very hot water and pour it inside the second containers. Add one thermometer in each containers and wait until the temperature reach the appropriate level as required. Hot water should be above 85 °C and cold water should be below 10 °C .

Experiment 1 : Create electricity from two different heat sources

Preparing the thermo-electrical module

- a. Insert the thermoelectrical module into the slot on its basis.
- b. Put the seals insides the holes you can see on the top of each tanks of the thermoelectrical module. Ensure you place the blue seal in the red socket side hole and the red one into the hole of the black plug side.
- c. Pour the water in each water tank in the thermoelectric system and ensure to fill the tank in the appropriate sense e.g. the cold water in the tank which shows the blue seal (red socket side), and the hot water on the opposite side (red seal and black socket). Ensure the central component is completely recovered by the water and the hot and cold water reaches the water level line marked on the water tank.

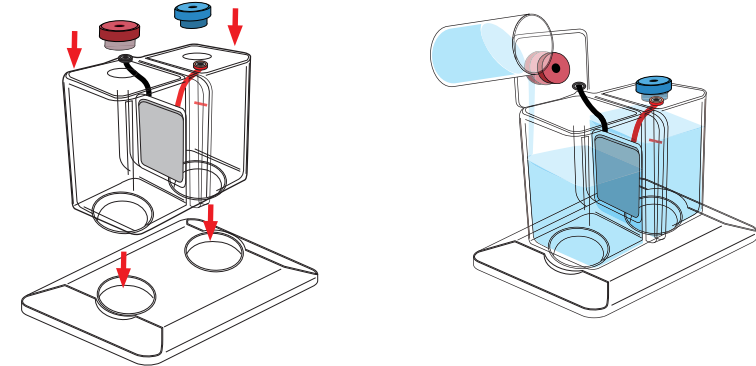

- d. Insert the thermometers in the holes of the seals carefully and slowly until it almost reaches the bottom of the tank.

Note: Thermometers are fragile and if you break them, there is risk of personal serious injury.

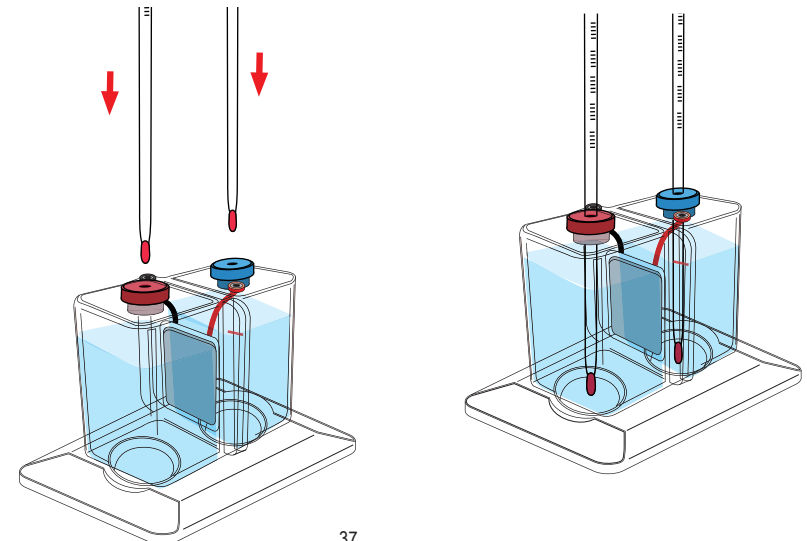

Preparing the fan module:

Remove the fan module from its box and insert the fan blade onto the motor axis. Ensure the connection is tight.

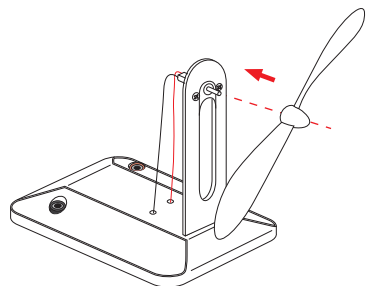

Power the fan with two heat sources:

Connect the wires into the fan plugs and into the thermoelectric system sockets. Ensure to respect the color code. You will see that the fan start to rotate immediately. It is due to the Seebeck's effect which turns heat into electricity.

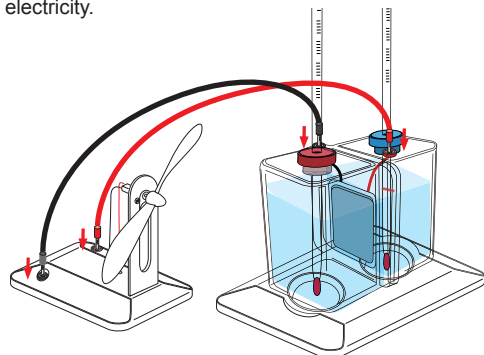

Note: At this moment, the temperature difference between the two sides should be more than 70°C. The temperature difference is proportional to the generated power. A 70°C difference of temperature is enough to power the fan for a long time. The power is generated due to Seebeck's effect which turns heat into electricity. There is a heat exchange between the two heat sources due to temperature difference. The hot water will progressively cool down and the cold one will be heated up. After a long time, both sides will reach the same temperature.

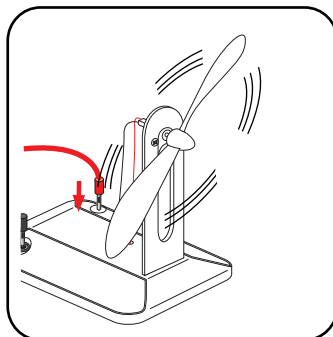

Power the LED module with two heat sources

Connect the wires into the LED module plugs and into the thermoelectric system sockets. Ensure to respect the color code. You will see that the LED starts to flash immediately.

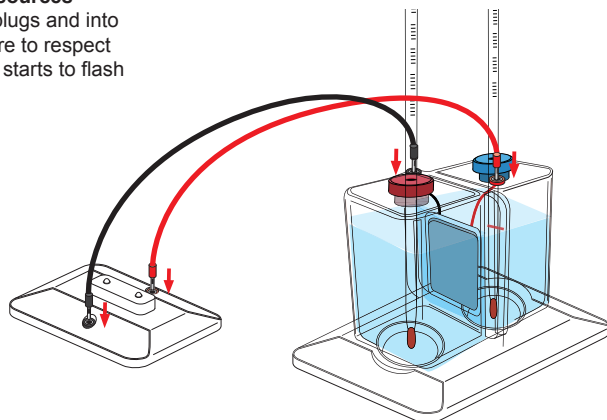

Experiment 2:

Do the same as in experiment 1, but this time connect the renewable energy monitor in order to be able to see the generated power. After connecting the wire and the fan, write every 2 minutes the temperature of each heat source and the corresponding value of power which is generated.

Time [minutes]	T _{hot} [°C]	T _{cold} [°C]	Temperature difference [°C]	Generated power [W]
0	90	10	80	
2				
4				
6				
8				
10				
12				
14				
16				
18				
20				
22				
24				
26				
28				
30				

Note: The temperature difference between the two water tanks will be narrowed with the time going, the electricity produced will also be reduced. The fan or LED light will operate in a weak way gradually until it stops.

Experiment 3:

- Do the same as in experiment 1 but connect the wires on the fan basis on the opposite sense than the one showed by the color code. You will see the fan start to rotate on the opposite sense. It is due to the motor ability to run when it is crossed by a current, no matter which direction it came from.
- Disconnect the fan and connect the LED module to the thermoelectrical generator. Ensure to respect the color code. You will see the LED light on then disconnect wires and plug them in the other sense. The LED will not light on because the current generated by the Peltier's module (central component of the thermal generator) goes only in one direction and LED only allow the current to pass in the other sense.

Experiment 4:

- Connect one thermocouple on each side of the Peltiers module, on the middle of the walls inside the tanks.
- Connect the electrical generator into the plugs of the thermoelectrical system. Input different current and write the value of the wall temperature. Wait 5 minutes between the time you increase the current and the moment when you write the temperatures.

Current [A]	Cold face temperature	Hot face temperature
	[°C]	[°C]
0		
0,25		
0,5		
0,75		
1		
1,25		
1,5		
1,75		
2		

You will see that temperatures start to vary as soon as you power the system. It is due to the reverse effect of Seebeck's one: Peltier's effect with occurs in the junction between two materials with are submitted to an electrical current. You will notice also that one side became colder and the other become warmer. It is absolutely normal with this kind of module. The last point to notice is the cold temperature decrease in first and after start to increase again even if it stay lower than the other side one. It is mainly due to thermal effect (conduction) inside the material and electrical effect due to the passing current (joules effect). In fact heat exchange start as soon as there is a difference of temperatures, and joules effect occurs every time a current pass through a resistive material. You can see a model which sum up all the heat exchange during the experiment (except radiation).

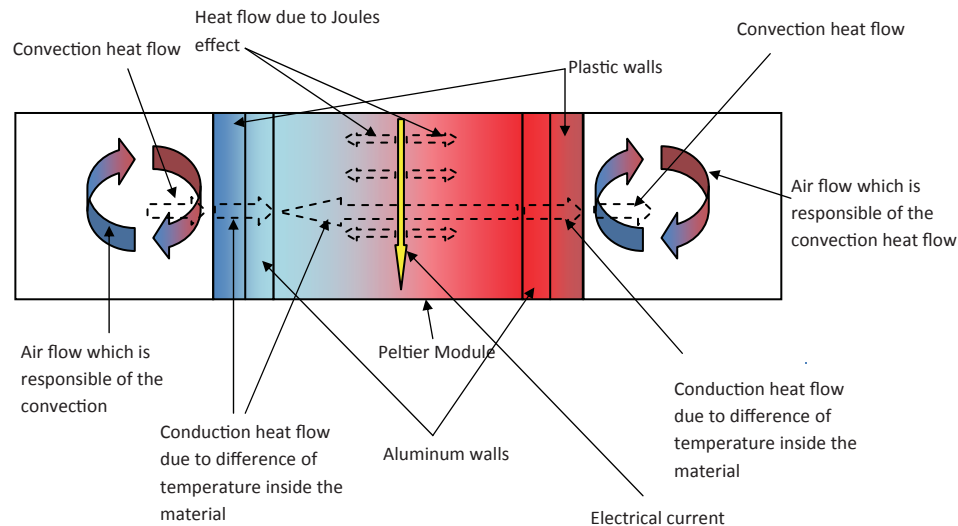

FAQ

1. What is a Peltier Module? What is SEEBECK effect ?

Peltier module is an electrical component wade with semiconductor. It is used to create heat when you input electricity inside. SEEBECK effect is a physical phenomenon which could be described by the appearance of a current in the junction between two materials when it is crossed by a heat flow.

2. What is a dipole? Do there is different types of dipoles? If yes, classify the dipoles contained in this kit.

Dipole is an electrical component which is made with 2 terminals. There is two kinds of dipole, the active ones and the passive ones. The first type of dipole is able to generate an electrical current and the second one can just receive current.

Dipole name	Type
Peltier module	Active
Fan motor	Passive
LED	Passive

3. What is a semiconductor? What is a PN Junction?

A semiconductor is a specific material which shows a special ability to react with its environment. This kind of material has a specific atomic structure with a lack or an excess of electrons. When this kind of material receive some energy (light, magnetism, thermal energy...), the electrons on the valance band (highest layer which could be completely filled with electrons) goes on the external layer called conduction band. When electrons reach this position, they could flows inside the material. In other words, the material becomes more conductors when the electrons reach valance band. Some semiconductors are made with several elements which have not the same number of electrons. If the added element shows a higher number of electrons, there is a local excess of electrons and the material is called n-type doped material. On the opposite side, the p-type doped semiconductor shows a lack of electron around the added element because this one has a lower number of electrons. A PN junction is composed of two semiconductors fixed together. When there is some energy which goes into the junction, both materials react becomes conductor. Due to the difference of electrical potential between the Positive (p-type) and the negative (n-type) part of the junction, a current appears.

4. What is the central component of the generator? With what physical effect does it function?

Quote another thermoelectric effect.

The central component is a Peltier Module. It works due to SEEBECK effect, which is the complementary effect of PELTIER effect.

Troubleshooting

After the hot water and cold water was poured into its water tank, the fan load does not work.

Solution: 1. Make sure all connections are correct.

2. Make sure the hot water is poured into the water tank with red seal and cold water into the water tank with blue seal.

3. Make sure the temperature difference is higher than 70°C.

4. Tap the fan blade with your finger to move it.

Salt Water Energy

What you need:

List of Components

- Salt water fuel cell
- Salt water fuel cell anode plate
- Fan module
- Salt water fuel cell base
- Fan blade
- Gradual container
- Wires
- Fan blades adapter
- Syringe and its tube
- REM USB cable
- REM

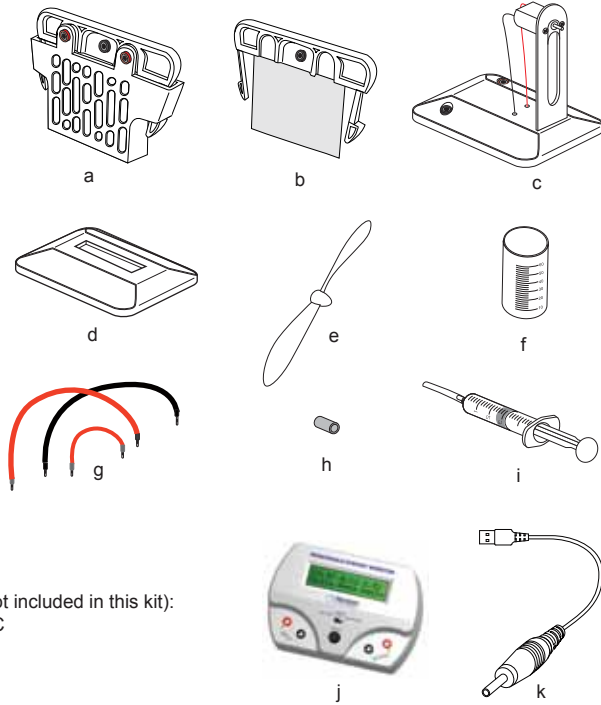

- You will also need the following items (not included in this kit):
- Purified or distilled hot water above 90C
 - Salt (food grade) 50g
 - Electronic balance

IMPORTANT NOTES:

- Take care with the hot water to not hurt yourself.
- Wearing waterproof gloves and glasses are highly recommended.
- Take care with the fan to not hurt yourself.
- After each use clean the anode plate to keep its best performance for later use.
- Store the anode plate in a dry place.

Prepare the water salted solution:

- Weight 15 mg of salt using a balance. In the gradual container, put the salt and add 25ml of hot water. The water temperature should be around 90°C (363 K).
- With a spoon, mix the container contents until the salt have been entirely melted into the water. Sometimes a small part of the salt stays in the solid state.

Experiment 1 : Create electricity from water salted solution

Preparing the fuel cell:

- Take the salt water fuel cell out of the packaging.
- In the same time press the lower part of the blue components you can see on each side of the fuel cell. By this way you can remove the fuel cell anode from the fuel cell tank.
- Insert the fuel cell cathode into the slot on its basis.

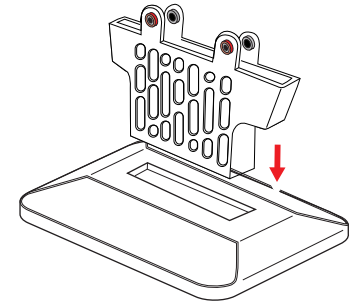
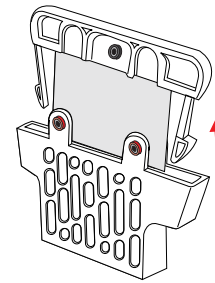

- With the syringe, suck up some salted solution and pour it into the cathode tank in order to fill $\frac{3}{4}$ of the maximum tank level (above 15mL).

- Take the metal made anode and clips it into the cathode as show below.

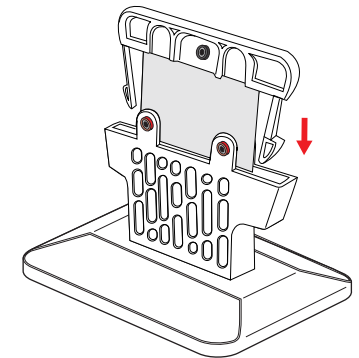
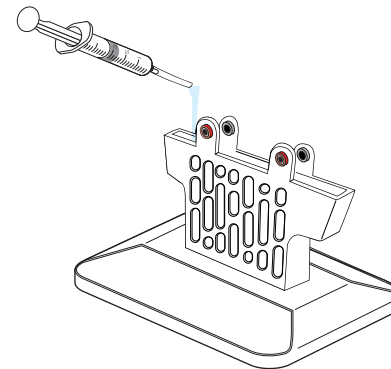

Connecting the wires into the cell:

- Place the fuel cell in front of you in order to see three plugs.
- Connect the short wire into left red plug and its other end into the left plug behind the cell.
- Connect the black long wire in the central plug and the red one in the front red plug.

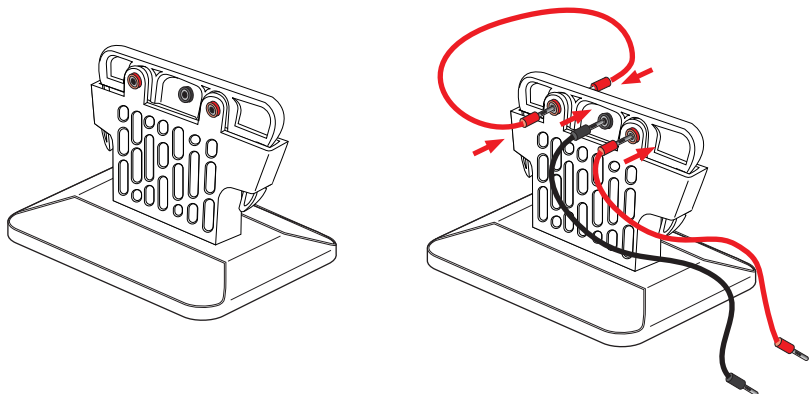

Preparing the fan module:

Insert the adapter around the fan motor axis. Put the fan blade onto the adapter and ensure the connection is tight.

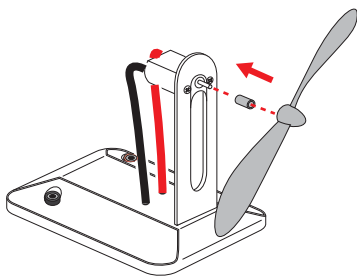

Power the fan with the salted water fuel cell:

- Connect the remaining end of the long wires into the fan module, and ensure to respect the polarity shown by the color code.
- You will notice that the fan will start to rotate as soon as the wires are connected into the fan module. The power generated by the solution is provided for minimum 4 hours.

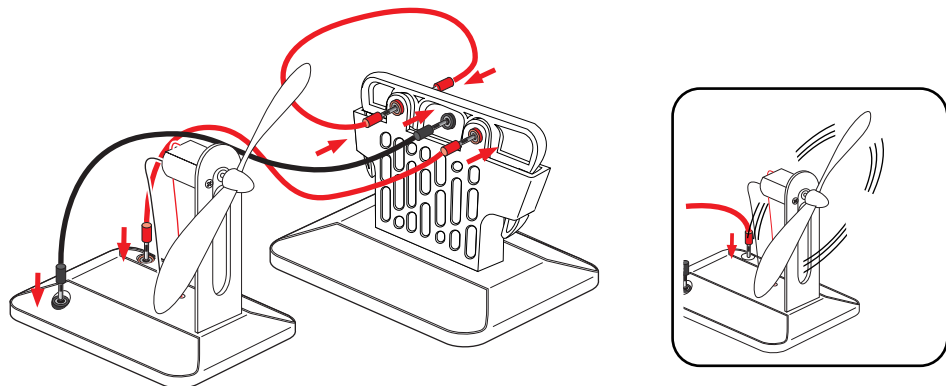

Experiment 2 : Using different salt concentrations

Do the same as in experiment one, but connect the REM to the fuel cell. Measure the output current and voltage of the fuel cell for the different salt concentrations you could find in the table below. Remember to clean the fuel tank between every time you change the salted water fuel. You will see that the salt concentration impact the fuel cell efficiency.

mass [g]	Salt concentration [%]	Current [A] / Voltage [V]
2	4%	
5	9%	
10	19%	
15	28%	
20	38%	

Experiment 3 : Using different water temperature.

Do the same as experiment 2 but this time, add 15g of salt in hot water (90°C) and let the mixture refreshen up. After that, heat it in order to reach the different temperatures shown below and measure the output current with the REM. Remember to clean the fuel tank between every time you change the salted water fuel. You will notice that the temperature is directly linked with the reaction efficiency and so to the provided energy.

Solution temperature [°C]	Current [A] / Voltage [V]
25	
45	
65	
80	
90	

Experiment 4 : Using different fuel volume

Prepare the mixture like in experiment 1 and this time use a chronometer (not provided) to measure the running time with different concentrations. You will see that the most important running time is reached when the tank is not fully filled.

Volume poured in the fuel tank [mL]	% of fuel tank volume	Current [A] / Voltage [V]
5	25%	
7	35%	
10	50%	
12	60%	
15	75%	

FAQ

1. What is a salt water fuel cell? How does it work?

This kind of fuel cell works with air and with a plate made with magnesium. The electricity is made by two chemical reactions which occur in two different points of the cell. The first part of the reaction is on the plate which is called anode. On this side, the water reacts with the magnesium and creates hydrogen ions (protons) and magnesium hydroxide and generates two free electrons. On the other part of the cell (cathode), the oxygen contained in the air which passes through the cell walls reacts with the water in order to constitute hydroxide ions. This reaction is possible only if there are additional electrons which are provided. So during the reaction, the free protons generated on the anode are attracted by the cathode because of the difference of potential. If the cell is linked to an electrical circuit, the free electrons will pass inside it in order to reach the cathode and let the second reaction happen. You can find the two half redox equations below.

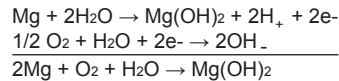

The salt in the water is used as a catalyst. In other words, it means that salt accelerates the reaction between Mg and water.

2. Is that possible to increase the output of salt water fuel cell? And how?

Yes. It is possible to increase the output of salt water fuel cell. You could increase the anode and cathode size to increase the output power. You could try to increase the salt solution temperature or you could increase the salt solution concentration to get high fuel cell output.

3. What is the best salt solution concentration?

You can do experiment 2: Using different salt concentrations to find the answer.

4. What is anode metal plate made of?

The metal plate is made of magnesium (Mg).

5. What are the specifications for the fuel cell?

Normally the output voltage is 1.2V and the current is 200mA.

6. Where can I buy the anode metal plate?

We can provide the anode metal plate. Please contact sales@horizonfuelcell.com for more information.

7. Are there any other energy related educational products? Where can I buy them?

We provide many types of energy educational products. They are related to solar power, hydrogen power, chemical power, mechanical power, wind power, thermal power etc. For more sales information, please contact sales@horizonfuelcell.com

8. How to maintain the fuel cell in good performances?

After each use, clean the fuel cell using fresh water. Ensure there is no remaining salt inside. Store the anode plate and fuel cell separately in a dry place.

9. What are the white particles on the anode metal plate?

They are the magnesium hydroxide and sodium chloride, as a result of reaction between salt water and metal plate.

Troubleshooting

I put the anode plate into the tank, but there is no electricity which is generated.

Solution: 1. Make sure the connections are correctly done.
2. Try to clean the anode plate, if it still does not work polish the metal parts.
3. Change the anode plate.
4. Ensure you have poured the salted solution into the tank.

Multi energy powered car

Part List

- a. Car frame
- b. Reversible fuel cell
- c. Hand crank generator
- d. Salt water fuel cell
- e. Mini fuel cell
- f. Battery pack
- g. Solar panel
- h. Super capacitor
- i. HYDROSTIK PRO pressure regulator
- j. Solar panel support
- k. HYDROSTIK PRO
- l. U fixator for HYDROSTIK PRO
- m. Fuel solution container
- n. Water & Hydrogen tank
- o. Water & Oxygen tank
- p. Clamp
- q. Wires
- r. Syringe
- s. Silicon tubes
- t. Red & black pins
- u. Purging valve

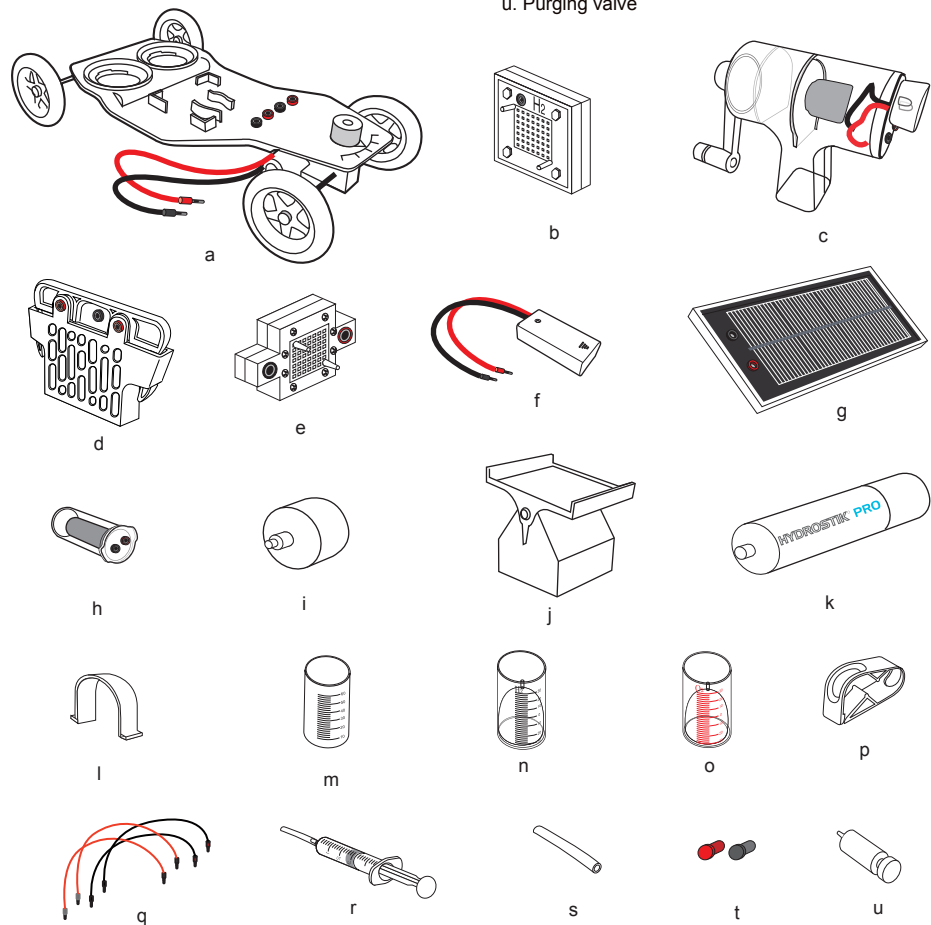

Solar Powered Car

What you need :

- a. Car frame
- b. Photovoltaic solar panel
- c. Wires
- d. Solar panel support

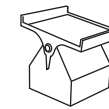
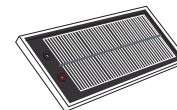
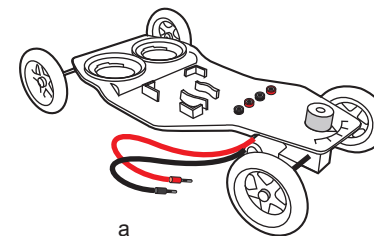

Important notes :

1. You can set the wheels position using the steering on the front of the car
2. Ensure that the electrical connections under the car are tight.
3. For the first use, remove the shrink-wrap from the solar panel.
4. The car should be run under direct strong sunlight.

Power the car with solar energy

Step 1. Fit the solar panel support onto the car. Ensure they strongly meet together.

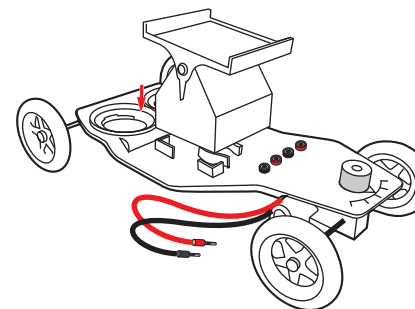

Step 2. Place the solar panel as shown in the picture below. Remind that the plugs have to be on the right side when you face the car.

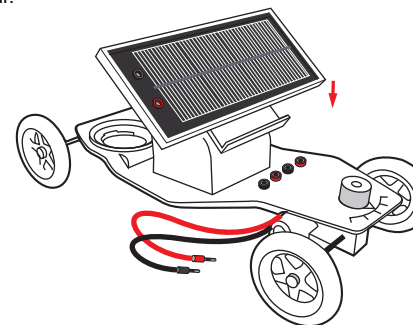

Step 3. Connect the engine wires which exceed the bottom of the car, to the closest red and black plugs.

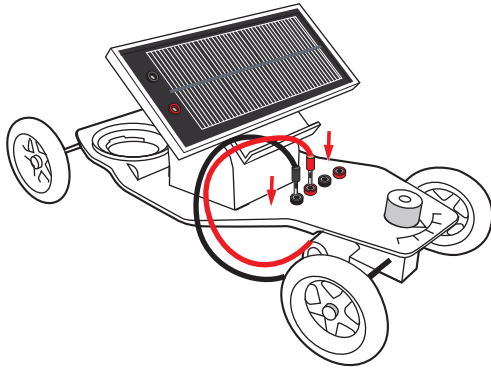

Step 4. Connect the solar panel and the car using the two remaining wires. Ensure to respect the polarity shown by the color code.

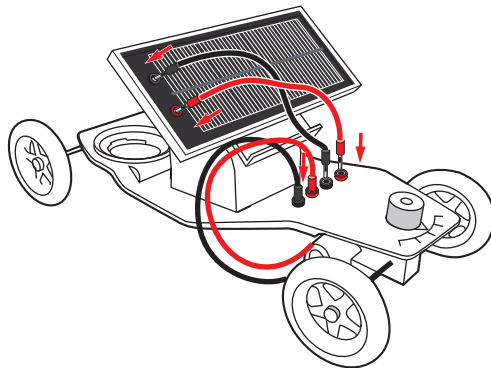

Step 5. Place the car under direct strong sunbeams to make it run.

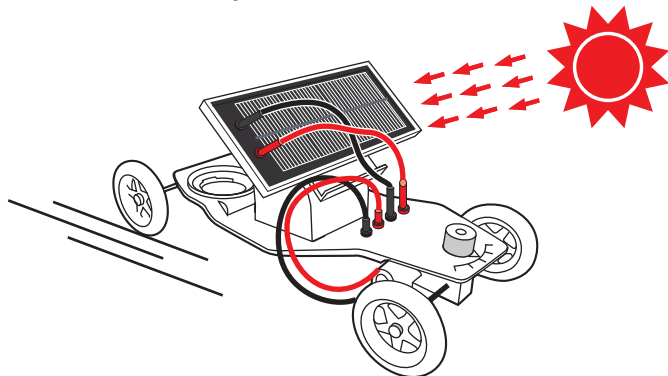

Hydrogen powered car

what you need:

- Water & hydrogen tank
- Water & oxygen tank
- Battery pack
- Car frame
- Silicon tubes
- Reversible fuel cell
- Syringe
- Red & black pins for tubes
- Wires

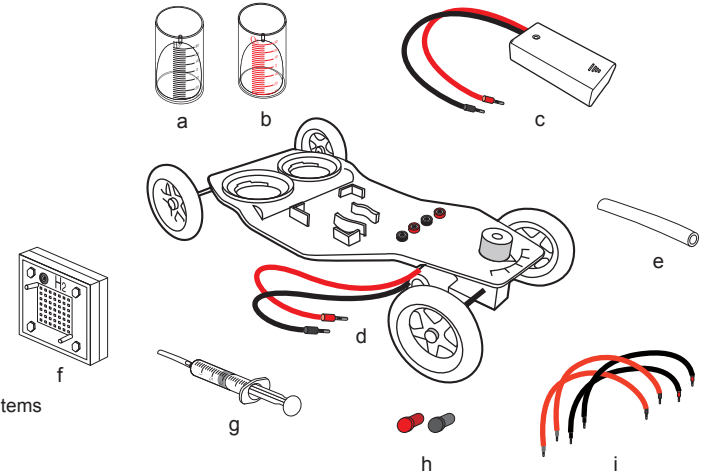

You will also need the following items (not included in this kit):
- AA batteries
- Purified or distilled water

Important notes :

- The O₂ tube have to be moist inside before use. On the contrary, the H₂ inlet have to be dry.
- Ensure that the electrical connections under the car are tight.
- Avoid any contact between the battery and water.
- Use only distilled or purified water to humidify the fuel cell with the syringe.
- You can set the wheels position using the steering on the front of the car.
- Keep the reversilbe fuel cell in a sealing bag for storage.

Preparing the fuel Cell

Step 1. Put one 5 cm long tube on the end of the syringe as shown below.

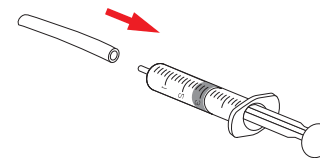

Step 2. Suck up some distilled or purified water and push it into the fuel cell by the nozzle which is the closest from the red plug of oxygen side of the fuel cell. As soon as the water flows out of the cell, disconnect the syringe from the tube and let this one connected with the fuel cell.

WARNING: The polymer membrane on the oxygen side is an important part of the proton exchange membrane (PEM) fuel cell, it should be prevented from drying out.

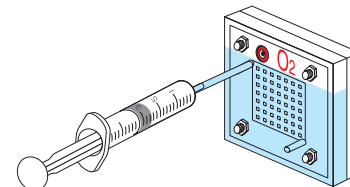

Step 3. Connect the other 5 cm long tube to the opposite nozzle (closest to the black plug) and add the red and black seals on each remaining end. Place the seal in function of the plug color.

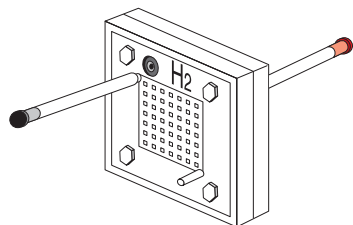

Step 4. Attach the water tank to the tank base on the car frame by pressing downward into round slots and twisting into place. Place inner gas tanks into outer water tanks minding that the gaps are not blocked by inner plastic rims.

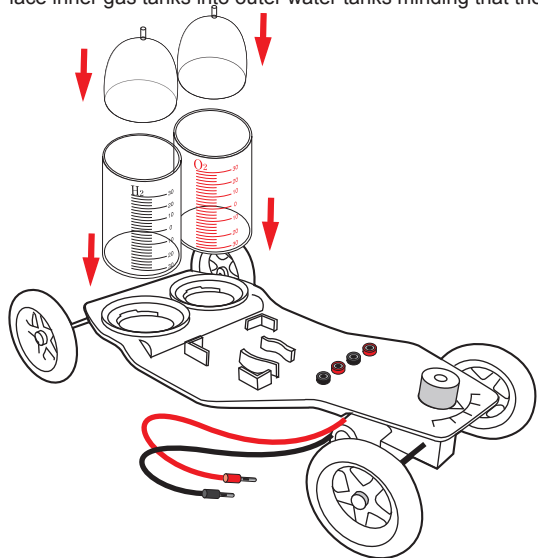

Step 5. Fill the containers with 40ml distilled water.

Note: You may use the syringe to suck up the air which could be trapped inside the inner gas tanks in each water tank. Ensure there is just water and no remaining air under the gas tanks.

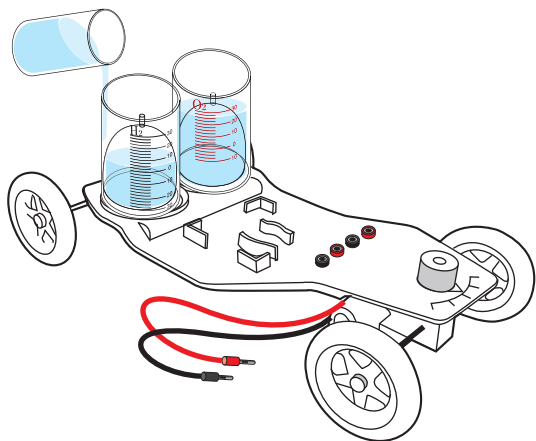

Step 6. Fit the reversible fuel cell onto the car frame, just in front of the containers and make sure the red plug is located on the O₂ container side.

Step 7. Connect the two 20cm long tubes onto the top nozzles of the inner gas tanks, connect the tubes opposite end to the lower nozzles located on the lower positions of both "H₂" and "O₂" side of fuel cell shown below. Make sure the tubes are connected correctly to the corresponding sides of the fuel cell.

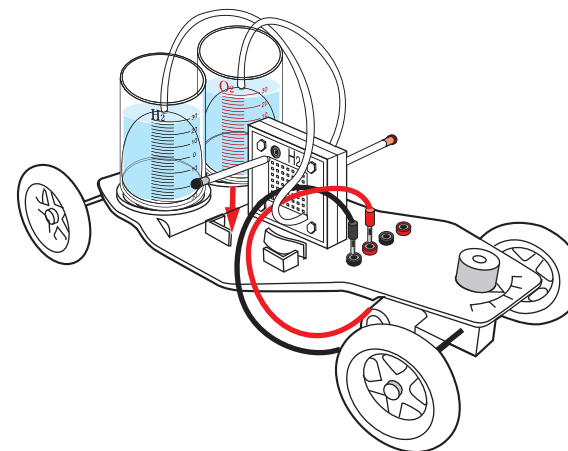

Create your fuel with water electrolysis and power the car.

Step 1. Open the battery pack and insert 2 AA batteries with the correct polarity.

Step 2. Connect the battery pack to the fuel cell and turn on the battery. Ensure to respect the polarity shown by the color code. You will see the inner gas tank will be filled by gas. You will also notice that the O₂ volume will be two times lower than the hydrogen one. It is absolutely normal, because water molecule is made with one atom of oxygen and two of hydrogen. When you see bubbles coming out from the inner tank, it means the inner gas tank is fully filled with gas. Turn off the battery pack and disconnect it.

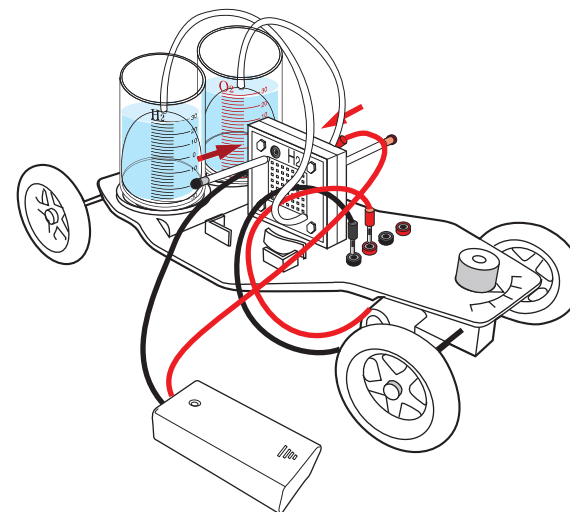

Step 3. Connect the engine wires which exceed the bottom of the car, to the closest red and black plugs.
Step 4. Using the two remaining wires, connect the fuel cell to the car frame. Make sure you respect the polarity shown by the color code. The car will run until there is no more hydrogen in the inner gas tank.

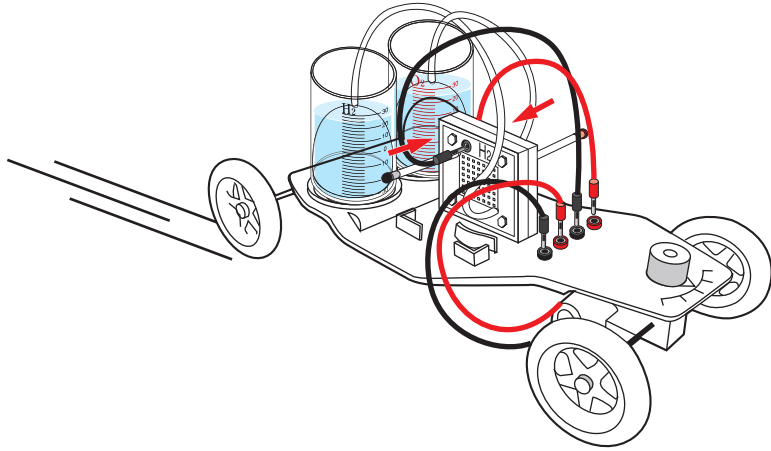

Troubleshooting

- The water levels do not drop when the gas outlet tubes on both sides of the fuel cell are unplugged.
Solution:
Check whether the holes on the wall of the inner cylinder are blocked. If so, turn the inner cylinder until water enters the holes and fills up the inner cylinder.
- The reversible fuel cell does not produce hydrogen and/or oxygen.
Solution:
a. Check whether the wires are appropriately connected, and whether there are any loose connections. The fuel cell could be completely destroyed if the red wire of the battery pack is connected to the black socket of the fuel cell.
b. Check whether the switch of the battery pack is in the "on" position.
- The water electrolysis process slows down.
Solution:
a. Add water to the oxygen side of the fuel cell and wait for about 5 minutes.
b. Replace old AA batteries with new AA batteries inside the battery pack.
- The car stops moving while there is still hydrogen left inside the tanks.
Solution:
a. Purge the gases and perform water electrolysis for 4-5 minutes. Unplug the hydrogen gas outlet tube and oxygen gas tubes to purge the gases. Perform water electrolysis again until the hydrogen tank is filled, and connect the motor to the fuel cell. If the problem persists, go to the next step.
b. Let the water electrolysis process last about 10 minutes to consume the residual water. To push water out of the fuel cell, purge the gases. Perform water electrolysis once more until the hydrogen tank is filled, then connect the motor to the fuel cell.

Super capacitor powered car

What you need:

- Car Frame
- Capacitor (energy storage)
- Wires
- Battery pack
- Hand generator (dynamo)

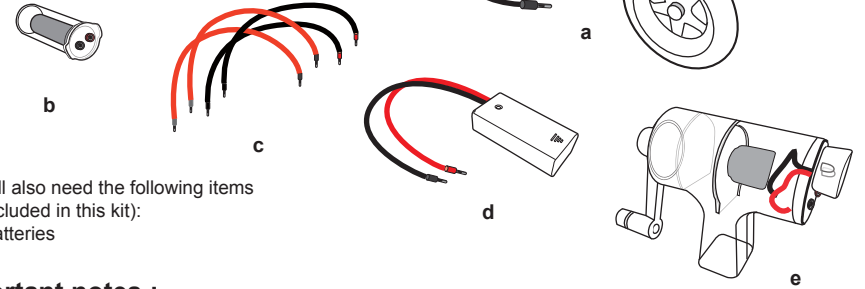

You will also need the following items
(not included in this kit):
- AA batteries

Important notes :

- You can set the wheels position using the steering on the front of the car.
- Ensure that the electrical connections under the car are tight.
- Do not load the capacitor if wires are connected in the wrong sense, otherwise you will broke the capacitor.
- The power stored is consequent, the car will start really fast so ensure there is free space in front of the car before connecting it.

Load the capacitor

Step 1. Open the battery pack and insert 2 AA batteries with the correct polarity.
Step 2. Using the wires, connect the capacitor to the battery pack and ensure to respect the polarity shown by the color code. Let the capacitor load during 1 min and then disconnect the capacitor. You can also use the hand generator to realize this operation. Connect it and ensure to respect the color code, turn the handle clockwise during 1 min with the velocity of two revolutions per second.

WARNING: 1. You are NOT allowed to rotate the arm anti-clockwise to charge the super capacitor. Otherwise the super capacitor will be damaged by the countercurrent.
2. DO NOT crank the arm too fast otherwise the hand crank generator could be easily broken by the strong force.

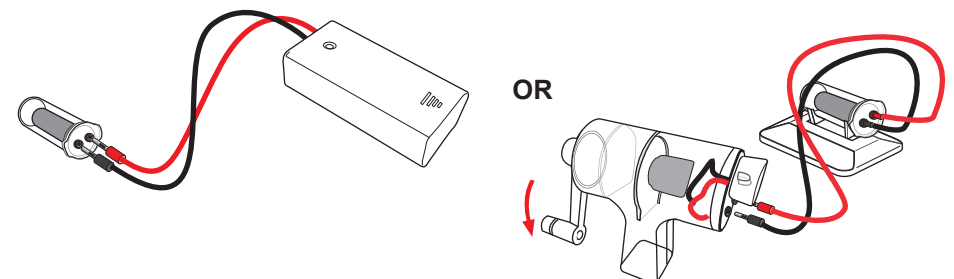

Power the car with the electricity stored in the capacitor

Step 1. Fit the capacitor onto the car frame.

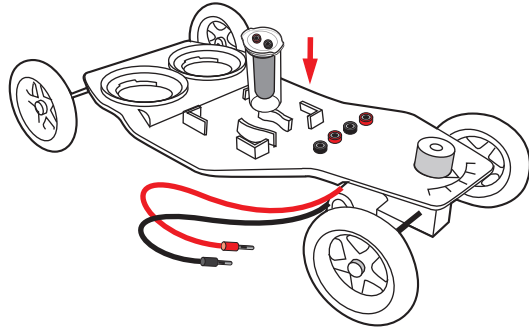

Step 2. Connect the engine wires which exceed the bottom of the car, to the closest red and black plugs.

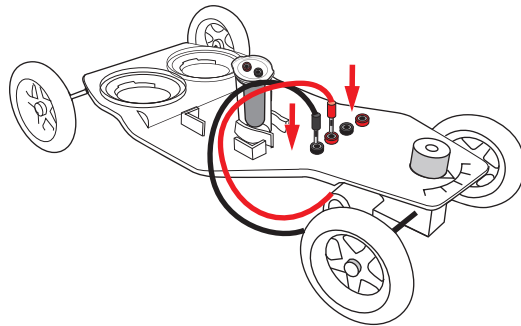

Step 3. Connect the capacitor and the car using the two remaining wires. Ensure to respect the polarity shown by the color code. The car will start to move immediately. If you connect wires in the wrong sense, the car will go back.

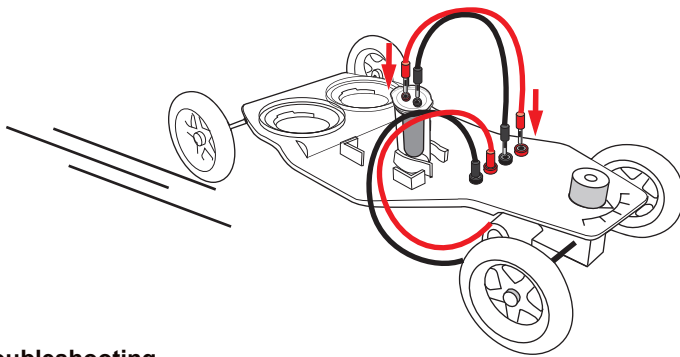

Troubleshooting

1. The bulb light on the hand crank generator does not work when I rotate the arm.
Solution: Replace the bulb light. It could have been damaged by long time using.
2. The car does not run when I connect the capacitor to it.
Solution: Charge the capacitor by using the battery pack or the hand crank generator.

Salt water fuel cell powered car

What you need:

- a. Car Frame
- b. Salt water fuel cell
- c. Gradual container
- d. Syringe and its tube
- e. Wires

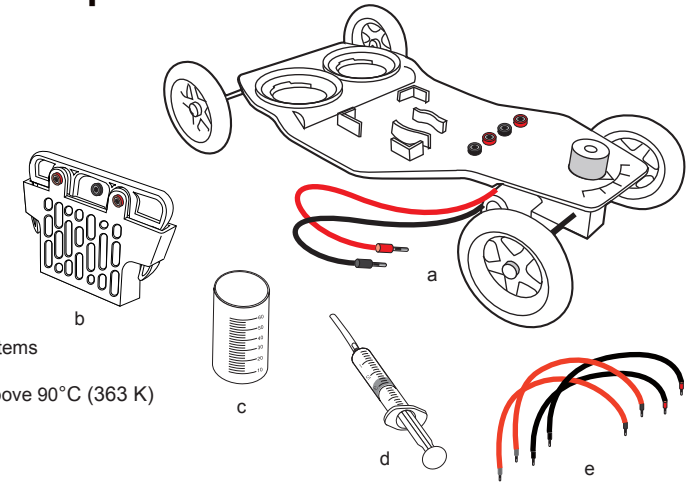

You will also need the following items (not included in this kit):

- Purified or distilled hot water above 90°C (363 K)
- Salt (food grade) 50g
- Electronic balance

Important notes :

1. Read carefully and clearly understand the instructions before assembling this kit.
2. You can set the wheels position using the steering on the front of the car.
3. Ensure that the electrical connections under the car are tight.
4. The temperature of the purified or distilled hot water should be above 90C.
5. Take care with the hot water to not hurt yourself.
6. Wearing waterproof gloves and glasses are highly recommended.
7. After each use clean the anode plate to keep its best performance for later use.
8. Store the anode plate and cathode tank in a dry place.

Prepare the water salted solution :

- Step 1. Weight 15 mg of salt using a balance. In the gradual container, put the salt and add 25ml of hot purified or distilled water. The water temperature should be above 90°C (363 K).
- Step 2. With a spoon, mix the container contents until the salt have been entirely melted into the water. Sometime a small part of the salt stay in the solid state.

Preparing the fuel cell

Step 1. Insert the fuel cell into the slot on the car frame. Press the lower part of the blue components you can see on each side of the fuel cell. By this way you can remove the fuel cell anode from the fuel cell tank.

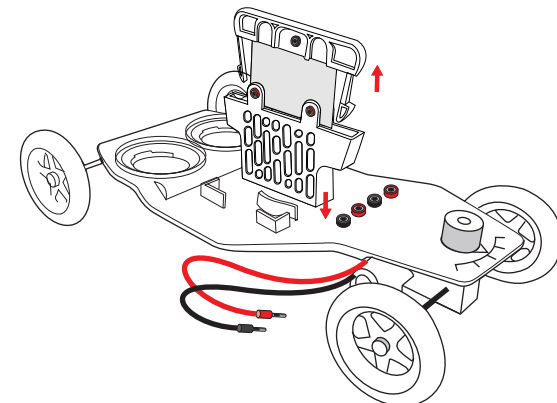

Step 2. With the syringe, suck up some water salted solution and pour it into the cathode tank in order to fill $\frac{3}{4}$ of the maximum tank level (about 15ml).

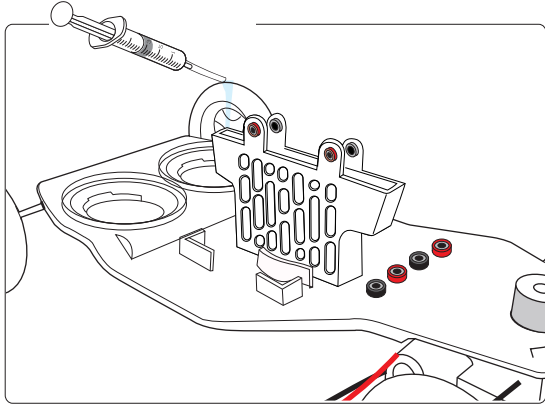

Step 2. Take the metal made anode and clips it into the cathode as show below

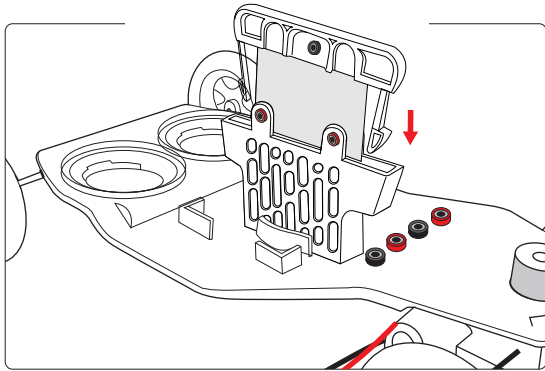

Connecting the wires into the cell.

Step 1. Place the fuel cell in front of you in order to see three plugs.

Step 2. Connect the small 10cm wire into left red plug and its other end into the right plug behind the cell.

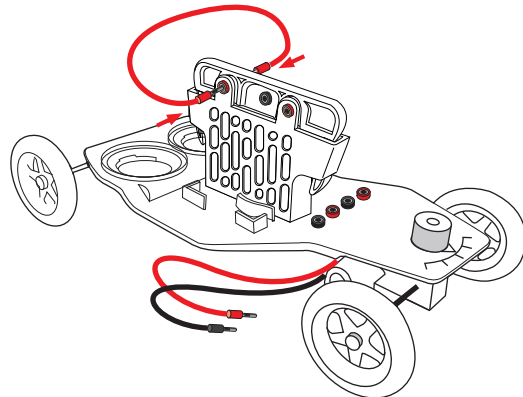

Step 3. Connect the car engine wires to the plugs on the car.

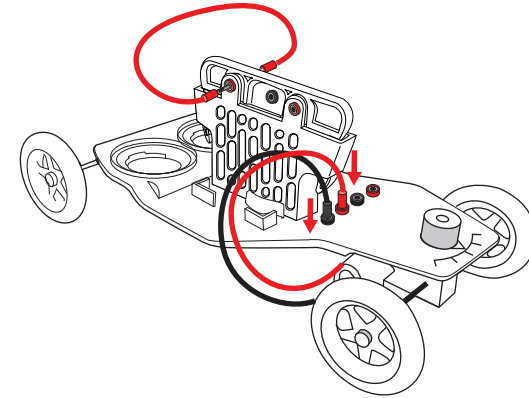

Step 4. Connect the black long wire in the central plug and the red on in the front red plug. Connect the other end of these wires into the car right plugs. The car starts to move. Ensure that you have connected the wires in the good sense. On the contrary, the car will go back.

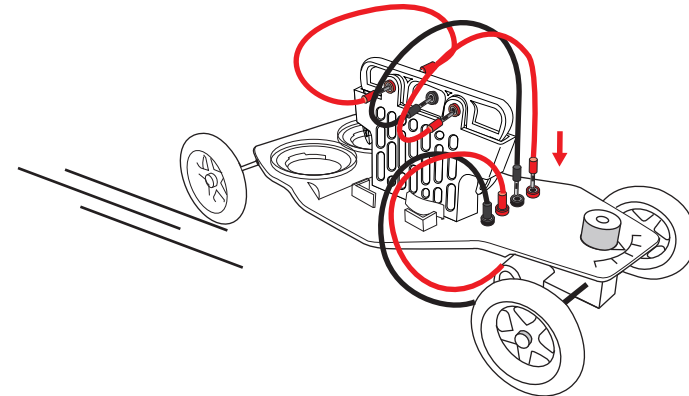

Note: After long time running, the car speed will slow or stop. If you want to continue to run the car, you should pull out the anode metal plate to clean it up with the running water. Replenish some salt solution to the fuel cell tank. Place back the anode metal plate to the cathode fuel cell tank, the car will continue to run. After use, you should pull out the anode metal plate and clean up the fuel cell tank with the running water. Keep them dry for storage.

Troubleshooting

The car does not run.

- Solution:
1. Make sure the connections are correctly done.
 2. Try to clean the anode plate, if it still does not work polish the metal parts.
 3. Change the anode plate.
 4. Ensure you have replenished the salted solution into the tank.

Power a car using a fuel cell and a hydrogen storage

What you need:

- a. Car Frame
- b. Mini fuel cell
- c. Wires
- d. Tubes
- e. Clamp
- f. HYDROSTIK PRO
- g. Purging valve
- h. HYDROSTIK PRO pressure regulator
- i. U fixator for HYDROSTIK PRO

You will also need the following items (not included in this kit):

- HYDROFILL PRO for charging the HYDROSTIK PRO
- Scissors

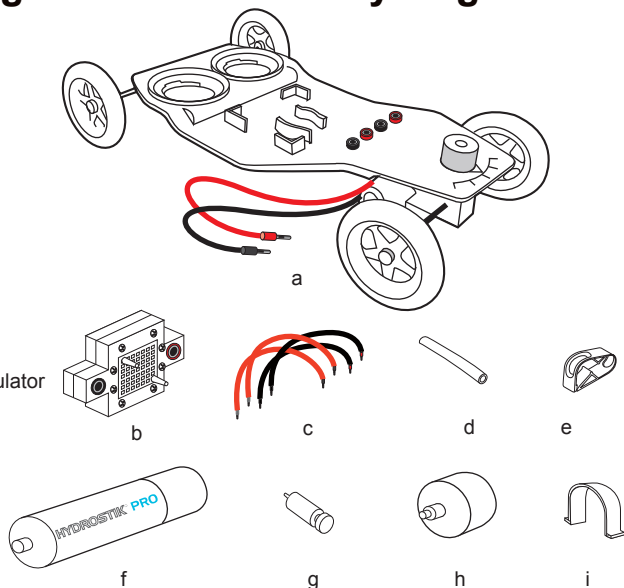

Note: The HYDROSTIK PRO contains no hydrogen when you get it for the first time, you have to fully charge the HYDROSTIK PRO with the refilling station HYDROFILL PRO (not provided) or hydrogen charging tube (not provided). Or please contact your local dealer for detailed information.

HYDROSTIK PRO SAFETY INFORMATION

- DO NOT try to disassemble, open or repair the cartridges when broken or worn out!
- DO NOT store cartridges under direct sunlight.
- Keep it away from fire. Fire Hazard!
- Keep in a safe, dry and cool place.
- Keep away from temperatures above 50°C while filling, storage and using.
- Provide adequate ventilation and refrain from placing items on or around the appliance during operation. Refrain from placing the appliance in enclosures or causing the appliance to not vent freely.
- Keep away from alkaline and acidic environment.
- This is not toy – keep away from children.
- The HYDROSTIK PRO must be placed horizontally when it is being charged otherwise the cartridge can crack!
- HYDROSTIK PRO contents are flammable. Do not disassemble. Avoid contact with HYDROSTIK PRO contents.
- Remove the HYDROSTIK PRO from the pressure regulator immediately after use.
- Hydrogen shall be stored, handled and used with caution so life and health are not jeopardized and the risk of property damage is minimized.
- This appliance is not tested for use with medical devices.
- Save these instructions and review frequently during use.

Preparing the hydrogen supply and the fuel cell

Step 1. Pass the tube through the clamp and close this one as shown below.

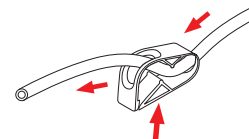

Step 2. Unscrew the bolt on the pressure regulator, and put it around the tube. Connect the end of the tube to the pressure regulator. Ensure the connection is tight, and then screw the bolt to the pressure regulator.

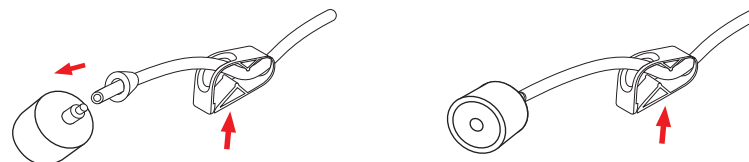

Step 3. Put the purging valve on the 5 cm long tube and ensure the connection is tight. Then, connect it to the nozzle you can see on bottom of the mini fuel cell.



Step 4. Place the U fixator on the back of the car frame. Then put under the HYDROSTIK PRO in order to be sure that it is correctly blocked.

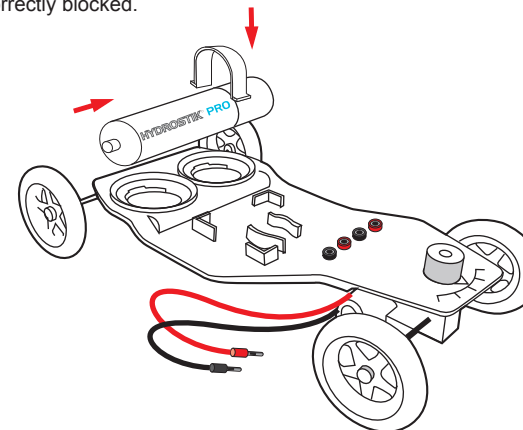

Step 5. Connect the other end of the pressure regulator tube to the fuel cell higher nozzle (close to the red plug). Then lightly screw the pressure regulator to the HYDROSTIK PRO. Stop to screw as soon as both parts fit together.

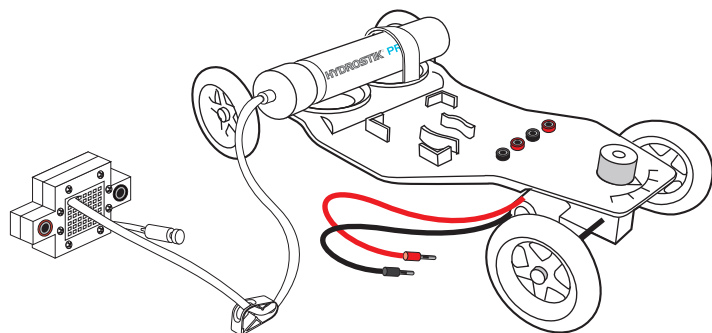

Step 6. After this place the mini fuel cell on the slot located on the car frame top. Ensure they fit well. Then connect the car engine wires into its plugs.

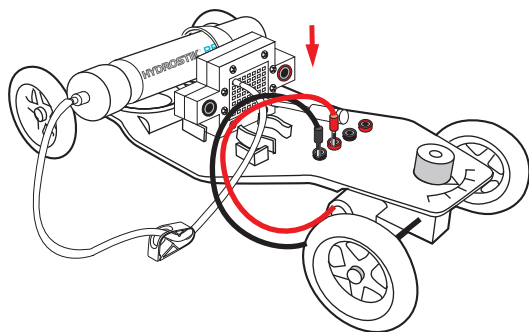

Step 7. Connect the two wires to the red and black plugs on the car frame. Connect the other end to the fuel cell.

Step 8. Open the clamp and finish to screw the pressure regulator to the mini fuel cell. Press the purging valve for two seconds and let a small amount of hydrogen pass through the mini fuel cell. The car will start to run.

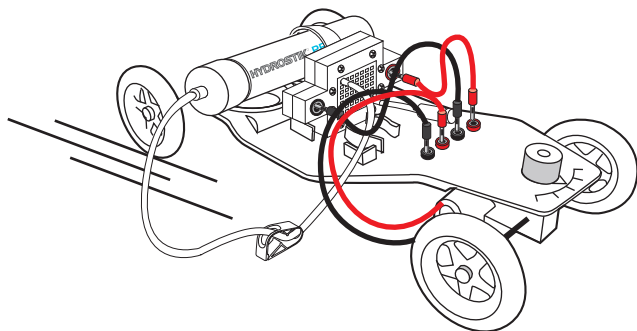

Hydrogen: Fuel of the Future

Hydrogen offers the promise of a sustainable energy source for the future of transportation, and the potential to greatly reduce CO₂ emissions. Hydrogen is the most commonly occurring element in the universe. It is a colorless, odorless, non-poisonous gas that is lighter than air. Hydrogen is one of the most important alternative fuels for the future, because it has the ability to replace all the fossil fuels used on the road today, and thus to reduce greenhouse gas emissions. The governments of countries around the world see the promise of hydrogen and are investing billions of dollars in research and development for hydrogen energy technologies. The U.S. Department of Energy has a Hydrogen Program that is working with industry, schools, laboratories, and other government agencies to overcome the obstacles standing in the way of widespread fuel cell adoption. They are addressing issues in hydrogen production, delivery, storage, safety, and fuel cell technology itself. According to HyWays, a research project funded by the European Union, building a hydrogen infrastructure in Europe would allow for a reduction in CO₂ emissions from automobile transportation of over 50 percent by 2050, and it could be done in an economically acceptable manner. A critical hurdle for the use of this innovative fuel that must be overcome is the distribution of hydrogen to individual automobiles. A large network of hydrogen fueling stations would need to be installed, just like our current network of gasoline fueling stations. This is only economically viable and feasible as a large-scale effort. Strong joint efforts from all of the stakeholders in both the public and private sectors is crucial to the successful adoption of hydrogen technology.

The Significance of the Fuel Cell

The fuel cell can play an important role as we change the way we meet our energy needs. It has a range of advantages:

1. It provides electricity in a more efficient manner than conventional power plants, which obtain electricity on a "detour" from chemically-produced heat energy through mechanical to electrical energy. The fuel cell, by contrast, creates electricity directly from chemical reaction energy (by "cold" combustion). So it has a significantly greater degree of efficiency than conventional types of energy conversion (with the exception of gas turbine power plants).
2. The fuel, which is hydrogen or other gases, can be obtained from renewable energy sources.
3. It is clean, since instead of climate-harmful CO₂, the only "waste" it releases is water vapor. Also, it is quiet.
4. Special fuel cells can be conveniently used in the cellar of a house as miniature off-grid residential heating and power units. In addition to electricity, they also give off plenty of heat from their gaseous fuel and the surrounding

Troubleshooting

1. The car does not run after the HYDROSTIK PRO supplies hydrogen to the fuel cell.
Solution: a. The car may need to be flicked with your finger to start.
b. Recharge the HYDROSTIK PRO fully.
c. Press the purging valve to purge a little bit amount of hydrogen out of the system.
d. Make sure the HYDROSTIK PRO is connected to the pressure regulator tightly.
2. The car runs slower than before.
Solution: a. Recharge the HYDROSTIK PRO fully.
b. Press the purging valve to purge a little bit amount of hydrogen out of the system.

Renewable Energy Monitor User Manual And Software Reference Guide

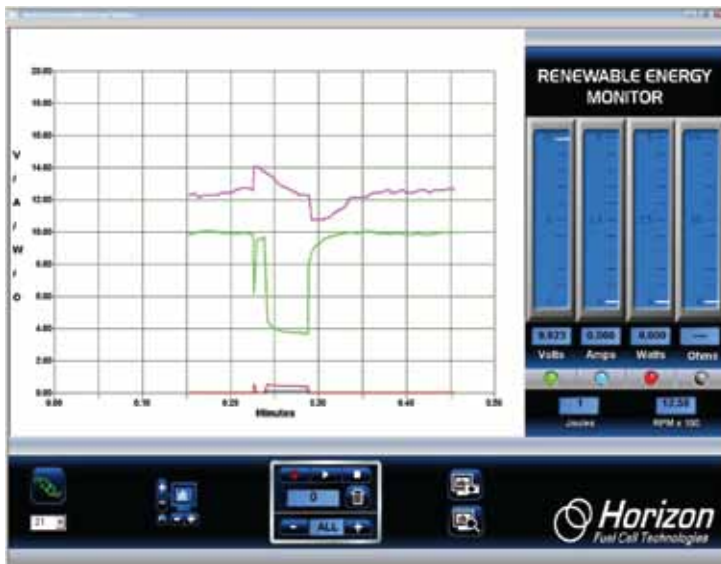
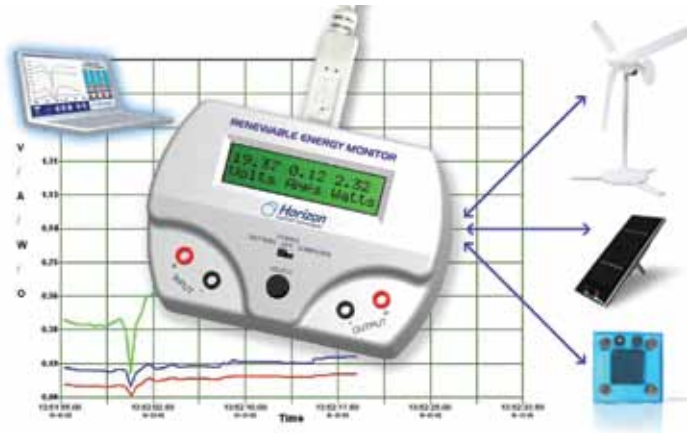

Introducing the Horizon Renewable Energy Monitor

The **Renewable Energy Monitor** is an educational evaluation monitoring device with PC measurement software for graphical display of performance characteristics on its own 2 line LCD screen or your Windows computer. It has a 2 line LCD screen for viewing measurements that you cycle through just by pushing a button.



And the **Renewable Energy Monitor** is battery operated and comes with a USB port so it can also be used with or without a computer – indoors or outdoors – where you can make direct solar and wind measurements.

And its power is in its simplicity!

Horizon developed the **Renewable Energy Monitor** to allow you to avoid using the multimeters confusing setup and cumbersome computations in order to provide an immediate, graphical way for recording data directly with no formulas and nothing to calculate. Numerous experiments and evaluation activities for hydrogen fuel cells, miniature wind turbine kits, and solar panels are now quantifiable in real time for voltage, current, power, joules, resistance, and even wind turbine RPM speed – all viewable and recordable at the same time!

The **Renewable Energy Monitor** is fully compatible with any of Horizon's educational kits.

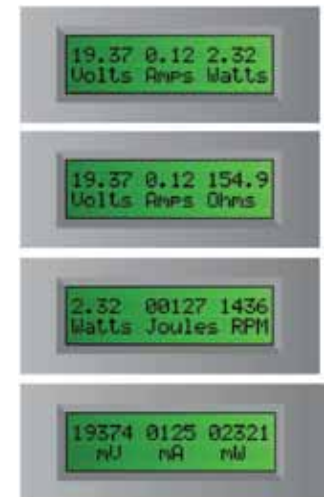

Switches

There are only two switches to operate:

- **Battery – OFF - Computer**
- **Select**

Set it to Battery when you want to make your measurements outside or without using a **computer**, or set it to Computer when it's plugged into your computer using the supplied USB cable. And set it to **OFF** when it's not in use.

Push the **Select** button to cycle through the four main LCD screens. You can even hold the **Select** button to “freeze” the display if the numbers are changing too fast.

USB Connection

A USB “type B” connector on the back of the unit allows connection to a Windows PC computer (MAC computers are not supported at this time). Power for the **Renewable Energy Monitor** is supplied by the PC via the USB cable.

Battery Requirements

The **Renewable Energy Monitor** uses a standard 9 volt radio battery that is easily replaced when necessary. The LCD screen will indicate when the battery is low and needs replacement. Be sure to set the switch to **OFF** to extend the battery life when not in use.



Units of Measurements

The **Renewable Energy Monitor** measures standard electrical units like voltage, current, power, energy and resistance. It also measures the RPM speed of the WindPitch wind turbine.

Voltage is measured in volts or millivolts (mV). A millivolt is 1/1000 of a volt but when seen on the LCD screen it can provide a more accurate measure of the voltage. For example...

1.23 volts = 1230 mV
10.456 volts = 10456 mV

Current is measured in amps or milliamps (mA). A milliamp is 1/1000 of an amp. For example...

0.003 amps = 3 mA
1.256 amps = 1256 mA

Power is measured in watts or milliwatts (mW). A milliwatt is 1/1000 of a watt. For example...

0.034 watts = 34 mW
2.987 watts = 2987 mW

Energy is measured in Joules. Energy is basically power x time and one Joule is equal to one watt-second. For example.

21 Joules = 21 watt-seconds or the amount of power used in 21 seconds.

RPM is a measure of the rotational speed of the wind turbines blades. RPM is used in experiments to show how the above parameters are affected by higher or lower RPM rates.

Input and Output Terminals



There are two sets of **Input** and **Output** terminals. The **Input** terminals are on the left side and the **Output** terminals are on the right side of the unit. The Red terminal is + or positive while the Black terminal is – or negative. You must observe the correct polarity when hooking up batteries, solar panels, wind turbines or fuel cells to the terminals.

Specifications

The **Renewable Energy Monitor** will measure electrical parameters up to the following limits:

Voltage: 0 - 28 VDC
Current: 0 - 1 amp DC
Power: 0 - 28 watts
Resistance: 0 - 999 ohms
Energy: 0 - 65535 Joules
RPM: 200 - 2500

Note: very low and very high RPM speeds cannot be accurately measured. Even though the wind turbine may be spinning the electronic circuitry is only capable of measuring a certain range of RPM speeds. Low voltage outputs from the WindPitch wind turbine may also affect RPM accuracy.

Common Equations

The **Renewable Energy Monitor** uses the following common equations internally to measure and compute voltage, current, resistance and power.

$V = I * R$ where V = voltage
I = current
R = Resistance

$P = V * I$ where P = power
V = voltage
I = current

$J = P * T$ where J = Joules
T = time in sec

Operating Tips

Electrical Fundamentals – Refer to the **REES Experiment Manual** for an explanation of the fundamental electrical parameters such as voltage, current, power, resistance and more.

Measuring Resistance – A voltage must be applied across the Input terminals in order to measure the resistance attached to the Output terminals.

Also, the resistance will vary depending on the voltage and current produced in the circuit. The **Renewable Energy Monitor** uses Ohm's Law to compute resistance, so any small variations in voltage and current will affect the resistance reading.

Software

Software for Windows PCs (XP, Vista and Windows 7) is provided to expand the operational capabilities of the **Renewable Energy Monitor**. MACs are currently not supported. Connect the USB cable between the Monitor and your computer for vivid graphical displays of data.

Installing the Software

Insert the supplied CDROM disc into your computer and follow the directions in order to load the software.

Running the Software

After the software is installed on your computer a Desktop icon like the one here is displayed. Double-click the icon to launch the software.



Tip: Always attach the USB cable between the Renewable Energy Monitor and the computer BEFORE you click on the REM icon to start the software. Then click on the Connect icon once the software is visible on your computer.

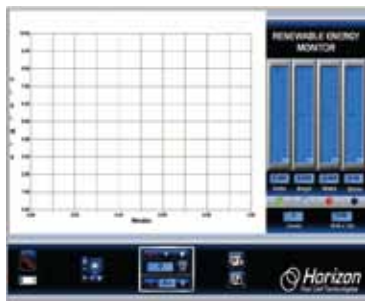

Connecting

Once the software is displayed on your computer screen, click the Connect icon on the bottom-right of the screen. It will turn from red to green to show that it is connected to the **Renewable Energy Monitor**.

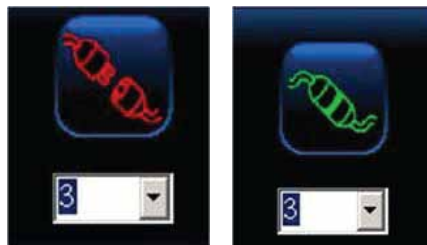

Tip: Nothing will happen unless you click the Connect icon and the number below it represents the com port attached to the Renewable Energy Monitor. Refer to the "More Details" section for a further explanation.

Plot Area

The plot area displays the line plots of voltage, current, power, resistance and RPM – all at the same time. This data is updated five (5) times a second from the Renewable Energy Monitor so it always represents the latest information coming from your experiments.

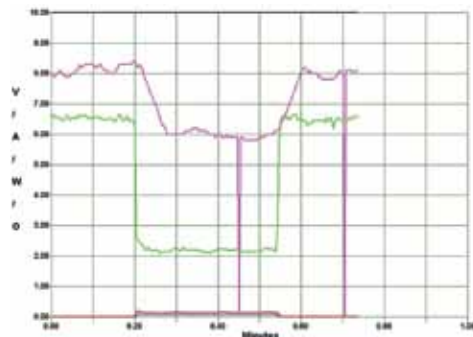

Color-Coded Plotting Lines

Each data plot is in a different color in order to make it easy to see what is being measured.

- Green - Voltage in volts**
- Blue - Current in amps**
- Red - Power in watts**
- Black - Resistance in ohms**
- Pink - RPM x 100**

Adjusting the Plot Scale

You can change the plot scale to match the incoming data from the Renewable Energy Monitor by using the Plot Scale icon. The vertical + and – control the vertical scale while the horizontal + and – control the time scale. Clicking the reverse arrow icon (bottom-left) clears the screen and allows a fresh plot of data to be displayed.



Meters and LED On-Off buttons

Four vertical meters display the voltage, current, power and resistance along with corresponding numbers at the bottom. Clicking any of the LED buttons at the bottom of each meter turns the corresponding plot line ON or OFF. The LEDs are color coded to match the plot lines to make it easier to understand.

Joules and RPM Display

Joules is a measure of energy (power x time). It is equivalent to a watt-second or the number of watts generated in one second and shows how much energy the experiment is generating.

RPM is displayed as RPM x 100 in order to better fit in the plot area. For example an RPM reading of 1436 is shown as 14.36.



Screen Snapshots

You can capture a snapshot of the screen at anytime by clicking the top Screen Capture icon. Then click the Screen View icon below it to see what you captured.

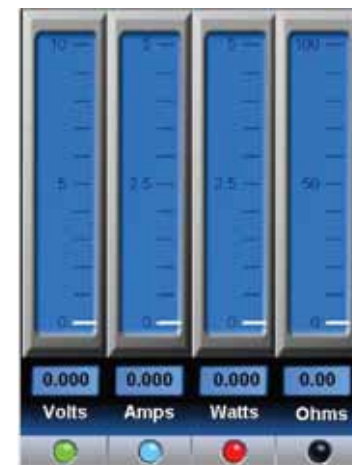

Data Recording and Playback Play and Pause

The built in recording feature is like recording a TV show for later playback except that you're using data coming from the **Renewable Energy Monitor** instead. The Recording and Playback controls are shown here.



The top three controls are...



Record Play – Pause Stop

Recording Data

Click the (round) Record icon to start recording data. The icon will change to a brighter red color.



Stop Recording

Click the (square) Stop icon when you're done recording. The Stop icon will momentarily change color from white to green – then back to white again. The red Recording icon will also turn off and the plot will go back to real time.



Click the (triangle) Play icon to begin replaying the recorded data. The Play icon will change from white to green during playback.



You can Pause the playback by clicking again on the (triangle) Play icon. It will change from a green triangle to a green double line. Click the Pause icon again to resume playback.



Recording Counter

The Recording Counter indicates the number of data samples that are (or have been) recorded for later playback. It can range from 1 to 999.



The Trash Icon

Click the Trash icon to erase all the recorded data. This will also reset the time on the plot area back to 0.0 minutes. You can push the Trash icon anytime; just make sure you really want to erase all the recorded data.

Sample Rate

You can control the rate at which you sample data by clicking the + or – icons on the Sample Rate indicator.



The default is ALL which means that all data from the Renewable Energy Monitor is recorded. Clicking the minus icon will slow the sample rate to the following:



Once each second ...



Every 2 seconds ...



Every 5 seconds ...

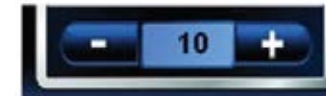

Every 10 seconds ...



Every 15 seconds ...

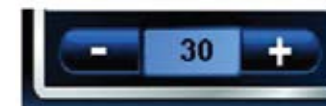

Every 30 seconds ...



Every 60 seconds ...

Zooming

While plotting data in real time or replaying data after recording, you can zoom in on a portion of the data at anytime. Simply position the mouse cursor over the area you want to zoom in to and click the left mouse button. Then release the left mouse button to execute the zoom feature.



Renewable Energy Monitor Excel® Interface Addendum



In addition to its already powerful real time graphical plotting and data logging software, the latest version of **Horizon's Renewable Energy Monitor** comes with the ability to transfer the logged data to an Excel® spreadsheet.

Example

Here's how it works....

By using the software's Recording and Playback features, each time a new Record – Stop or Record –Play sequence is performed, an Excel® compatible CSV (comma separated variable) file is written to the hard disk. The file name begins with the letters REM and contains the date and time the recording was begun.

Example:
REM_05_31_11_at_15_44_03

By simply importing this file into your Excel® spreadsheet you can do further analysis on the recorded data including plotting the variables in any order or style that suits your application.

The CSV files can be found on your hard disk in the same folder as the captured screen .jpg files. Just look under **C:/Desktop/ Documents/Horizon/file**

1. To start a Recording, click the red REC button. It will change from dull to bright red indicating that data is being recorded.



2. At the same time a new CSV text file is opened and the incoming voltage, current, power, resistance, RPM and Joule data are saved in the file.

3. To end the recording, click the triangular Play or square Stop button. The REC button will turn dull red again and the Play or Stop button will turn green. This will also close the CSV text file where it can be imported into Excel®.



4. To locate the CSV text file go to **C:/Desktop/ Documents/Horizon** folder where you will find the file mixed in with other previously saved screen capture images. If your folders are set to view files as icons you should see something like this.



5. The file with the Excel® logo is the one(s) you want to use to import into Excel®.

6. To import the file into Excel® you can 1) simply double-click on it or 2) launch Excel® manually, find the folder and open the file normally. The data should look something like this →

	A	B	C	D	E	F	G	H	I
1	Date	Time	Sample	Plot Seconds	Voltage	Current	Power	Resistance	
2	06/02/11	12:59:59	1	3.25	6.005	0.053	0.318	113.3	
3	06/02/11	12:59:59	2	3.25	6.003	0.053	0.32	113.77	
4	06/02/11	12:59:59	3	3.52	6.142	0.053	0.326	115.89	
5	06/02/11	12:59:59	4	3.75	6.03	0.053	0.32	113.77	
6	06/02/11	13:00:00	5	4.03	5.976	0.053	0.317	112.75	
7	06/02/11	13:00:00	6	4.27	6.059	0.053	0.321	114.32	
8	06/02/11	13:00:00	7	4.48	6.096	0.053	0.318	113.3	
9	06/02/11	13:00:00	8	4.75	5.976	0.053	0.317	112.75	
10	06/02/11	13:00:01	9	5	6.005	0.053	0.318	113.3	
11	06/02/11	13:00:01	10	5.3	5.947	0.053	0.315	112.21	
12	06/02/11	13:00:01	11	5.53	5.947	0.053	0.315	112.21	
13	06/02/11	13:00:01	13	5.76	5.893	0.053	0.312	111.19	
14	06/02/11	13:00:02	14	6.04	5.893	0.053	0.312	111.19	
15	06/02/11	13:00:02	15	6.28	5.918	0.053	0.314	111.66	
16	06/02/11	13:00:02	16	6.54	5.893	0.053	0.312	111.19	
17	06/02/11	13:00:02	17	6.79	5.947	0.053	0.315	112.21	
18	06/02/11	13:00:03	18	7.03	6.005	0.053	0.318	113.3	
19	06/02/11	13:00:03	19	7.28	6.005	0.053	0.318	113.3	
20	06/02/11	13:00:03	20	7.54	5.918	0.053	0.314	111.66	
21	06/02/11	13:00:04	21	7.81	5.976	0.053	0.317	112.75	
22	06/02/11	13:00:04	22	8.03	5.947	0.053	0.315	112.21	
23	06/02/11	13:00:04	23	8.28	5.918	0.053	0.314	111.66	
24									
25									
26									

7. You can then proceed to manipulate the data in anyway you choose including generating plots directly from it.

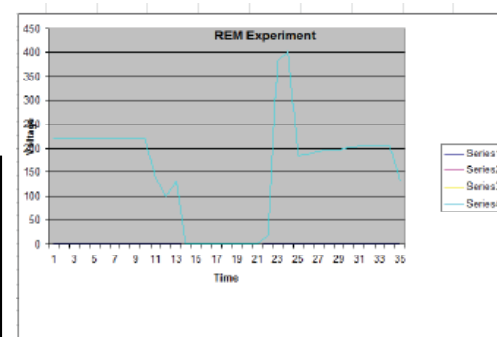

Refer to Horizon's **Renewable Energy Monitor User Manual and Software Reference Guide** for a complete description of all the software features.

The new Excel® feature is available in software version 1.10 and above.



For more information
contact sales@horizonfuelcell.com

www.horizonfuelcell.com